



REQUEST FOR PROPOSAL

Fire Loop Installation at the TSTC Sweetwater Campus

RFP-19-ND-008

NIGP Class Code(s): 913-56

RESPONSES ARE DUE BEFORE:
Thursday, October 3, 2019, 2:00 PM CST

POINT OF CONTACT:
Nereida Dominguez, CTPM
Texas State Technical College
Phone: (956)364-4429
nereida.dominguez@tstc.edu

TABLE OF CONTENTS

SECTION 1:	GENERAL INFORMATION
SECTION 2:	SCOPE OF WORK
SECTION 3:	PROPOSAL REQUIREMENTS
SECTION 4:	EVALUATION
SECTION 5:	FORMS
	FORM A: EXECUTION OF OFFER
	FORM B: DEVIATION/COMPLIANCE SIGNATURE FORM
	FORM C: NON-COLLUSION STATEMENT
	FORM D: REFERENCES
	FORM E: INTERLOCAL AGREEMENT CLAUSE
	FORM F: HUB SUBCONTRACTING PLAN (Submit if Proposers Bid Response is over \$100,000)
	FORM G: CONFLICT OF INTEREST
	FORM H: NO BID RESPONSE (OPTIONAL)
SECTION 6:	MISCELLANEOUS
	ATTACHMENT A: TSTC FIRE LOOP SPECIFICATIONS
	ATTACHMENT B: FIRE LOOP CONSTRUCTION DRAWINGS
	ATTACHMENT C: BID SCHEDULE
	ATTACHMENT D: STATEMENT OF BIDDER'S QUALIFICATIONS
	ATTACHMENT E: SAMPLE CONTRACT
	ATTACHMENT F: STATE MAP

SECTION 1: GENERAL INFORMATION

1.1 Background of Texas State Technical College

Texas State Technical College (“TSTC” or “College”) a state-supported two-year technical college and is the state’s largest provider of technical education. TSTC was originally established in 1965 as the James Connally Technical Institute (JCTI), a two year college in the Texas A&M University System designed to meet the state’s evolving workforce needs. In 1969, the State of Texas gained ownership of James Connally Air Force Base and renamed the college Texas State Technical Institute (TSTI), which became a separate state agency with its own Board of Regents, appointed by the governor. TSTC has been accredited by Southern Association of Colleges and Schools Commission on Colleges (SACS-COC) as a Level I institution since 1968. The College is an open enrollment institution with a full-time equivalent enrollment of approximately 12,000. In contrast with Texas’s regionally-focused community colleges, TSTC has a statewide role and mission with a legislative mandate to focus specifically on highly specialized, advanced, and emerging technical and vocational areas leading to certificates or associate degrees.

In 2015, the College was granted single-accreditation status from the SACS-COC, the regional body for the accreditation of degree-granting higher education institutions in the Southern states. TSTC central administration is located in Waco, Texas, the site of the flagship campus. The College services students throughout the state of Texas at campuses located in Abilene, Breckenridge, Brownwood, Fort Bend County, Harlingen, Marshall, North Texas (Red Oak), Sweetwater, Waco, and Williamson County.

1.2 Purpose of the Request for Proposals

TSTC is requesting proposals for a contractor to install a 10-inch fire loop around the TSTC Campus in Sweetwater, Texas; including 5,200 linear feet of 10-inch PVC water lines, valves, fire hydrants and incidentals (“Project”), in accordance with the terms, conditions, and requirements set forth in this Request for Proposals (“RFP”). The Proposer is to supply all material, labor, and equipment and supervision required to perform the service.

1.3 Submission of Proposal

Pursuant to *Texas Government Code Title 10, Subtitle D, Chapter 2156.121-2158.127*, sealed proposals will be received until the date and time established as the submittal deadline. After the submittal deadline, proposals will be opened and only the names of Respondents that properly submitted a Proposal will be made public. Prices and other proposal details will only be divulged after the contract award, if one is made.

Proposals must be received before the hour and date specified as the submittal deadline. Any proposal received after the expiration of the submittal deadline will be immediately disqualified from consideration.

Proposals will not be accepted by telephone, fax, or email. Proposals will only be accepted at the address below:

Nereida Dominguez
Texas State Technical College
1902 N. Loop 499
Harlingen, Texas 78550
Phone: 956.364.4429
nereida.dominguez@tstc.edu

Submit one (1) original signed proposal and one (1) identical electronic copy of the original signed proposal including all of its contents (“Proposal”). The original Proposal should contain the mark “original” on the Proposal Cover Page. The electronic copy shall be submitted in a USB/Flash Drive or CD in the same envelope as the hard-copy original proposal.

Proposal must be enclosed in a sealed envelope (box or container) addressed as described above. The envelope must clearly identify the RFP number, submittal deadline, and the name and return address of the Respondent. Proposal and any other information submitted by a Respondent in response to this RFP shall become the property of TSTC and will not be returned.

TSTC will not provide “delivery or hand stamp” receipt of Proposal or proof of delivery of Proposal which are delivered by hand or courier.

Failure to comply with all requirements contained in this RFP may result in the rejection of the Proposal. Proposals that are qualified with conditional clauses, alterations, items not called for in the RFP, or irregularities of any kind are subject to rejection.

By submitting a Proposal in response to this RFP, Respondent acknowledges and accepts the evaluation process and that determination of the “best value” will require subjective judgments by TSTC.

1.4 Questions and Clarifications

All questions and clarifications regarding this RFP must be submitted in writing to Nereida Dominguez, at nereida.dominguez@tstc.edu no later than **Friday, September 20, 2019 10:00 AM CST**. TSTC reserves the right to request clarification of any information contained in a proposal. Any clarifications or interpretations of this RFP that materially affect or change its requirements will be issued by TSTC as an Addendum. All such Addenda will be issued by TSTC before the submittal deadline as part of the RFP and Respondents shall acknowledge receipt of each Addendum to the RFP in proposal submission.

1.5 Schedule of Events

Issuance of RFP	Monday, August 26, 2019
Pre-Submittal Conference	Friday, September 13, 2019

Deadline for Written Questions	Friday, September 20, 2019 10:00 AM CST
Issuance of Addendum (if necessary)	Wednesday, September 25, 2019 10:00 AM CST
Submittal Deadline	Thursday, October 3, 2019 2:00 PM CST
Evaluation and Selection Period (tentative)	October 7 – October 18, 2019
Interviews and Negotiations (optional)	October 21 – 25, 2019
Award/Issuance of Purchase Order (tentative)	November 1, 2019

1.6 MANDATORY PRE-SUBMITTAL CONFERENCE:

Due to site conditions as well as the operational order, of which are mostly impossible to convey without seeing it in person, there will be a mandatory pre-submittal conference. Engineer will be present to discuss the scope of work and to answer questions involving the design of the fire loop.

Pre-submittal conference will be held at TSTC Sears Building Room 170, 300 Homer K. Taylor Drive, Sweetwater, Texas 79556 on **September 13, 2019 at 11:00 AM – 2:00 PM CST**. Lunch will be served at 12:00 PM. To ensure there’s enough food and drink for everyone, **please send your RSVP response to Shellie Glass, shellie.glass@tstc.edu, 325-235-7380 by no later than September 11, 2019.**

Agenda

- 11:00 AM CST - Presentations by Jacob Martin and TSTC.
- 12:00 PM - Lunch
- 12:45 PM - Site Visit

Questions and answers addressed during the site visit will be included in addendum issued on September 25, 2019.

1.7 Historically Underutilized Business Submittal Requirements

It is the policy of TSTC to promote full and equal opportunities for the contracting and subcontracting of Historically Underutilized Businesses (HUB) in accordance with *Texas Government Code*, Chapter 2161. This Chapter applies to all contracts for the purchase of goods and/or services with an expected value of \$100,000 or more.

A HUB Subcontracting Plan Form (Included as Separate Attachment) must be filled out and returned with the Proposal to be considered responsive. If the Proposal does not include a HUB Subcontracting Plan, it shall be rejected as a material failure to comply with advertised specifications.

Search the State of Texas HUB Database for HUB vendors by the NIGP class and item at:

<https://mycpa.cpa.state.tx.us/tpasscmlsearch/index.jsp>

Additional minority and women owned business association resources are available for subcontracting notices at: <http://comptroller.texas.gov/procurement/prog/hub/mwb-links-1/>

Additional information and training regarding how to complete a HUB Sub-Contracting Plan can be found on the CPA Website at the following link: <http://comptroller.texas.gov/procurement/prog/hub/hub-subcontracting-plan/>

1.8 Subcontracting Approval

The Respondent shall perform the Contract with its own resources and those subcontractors identified in the Respondent's HUB Subcontracting Plan. In the event that the Respondent should determine that it is necessary or expedient to execute additional or alternative subcontracts for any of the performances under the Contract, the Respondent shall submit a revised HUB Subcontracting Plan for prior approval before executing any subcontracts.

In any subcontracts entered into by Contractor for the performance of the work, Contractor shall require the Subcontractor, to the extent of the work to be performed by the Subcontractor, to be bound to Contractor by the terms of the contract between Contractor and TSTC and to assume toward Contractor all of the obligations and responsibilities that Contractor, by the contract between Contractor and TSTC, assumes toward TSTC.

The Respondent shall manage all quality and performance, project management, and schedules for subcontractors. The Respondent shall be held solely responsible and accountable for the completion of all work for which the Respondent has subcontracted.

1.9 Proposal Requirements

Proposals cannot be altered after the proposal submittal deadline and must be firm for up to 60 days from the submittal deadline. Proposals cannot be withdrawn after submittal deadline without written approval by TSTC based on a written request to withdraw.

1.10 Signature, Certification of Proposer

Proposals submitted without the required forms and authorized signatures, as specified in Section 3 (Proposal Requirements) and Section 5 (Forms) are subject to disqualification at TSTC's sole discretion.

1.11 Proposal Evaluation and Award Process

Proposals will be evaluated in accordance with Section 4.1 of the RFP.

1.12 Exceptions to RFP

Any exceptions to terms, conditions, and requirements of the RFP, including the Service Agreement, must be made in writing and noted in the Proposal. Please refer to Section 5, Form B for the required form.

1.13 No Reimbursement for Proposal Costs

TSTC specifically disclaims the responsibility and/or liability for all costs, expenses, or claims related to or arising out of the proposers' participation in this RFP process, including but not limited to costs incurred as a result of preparing, copying, shipping, presenting, and/or clarifying their Proposal and the information relevant to the Proposal. Proposers acknowledge and accept that any costs incurred from proposers' participation in this RFP process shall be at their sole risk and responsibility.

1.14 Taxes

As an institute of higher education and agency of the State of Texas, TSTC is exempt from payment of Texas State and local sales or use taxes on all purchases (*Texas Tax Code, Section 151.309*). Do not include sales tax in Proposal. Tax exemption certificates are available upon request.

1.15 Reservation of Rights

TSTC reserves the right to modify the RFP, divide the Scope of Work into multiple parts, and reject any and all proposals to re-solicit for new proposals or temporarily or permanently abandon the RFP prior to the date on which TSTC's delegated authority executes a contract with the selected Proposer.

1.16 Texas Public Information Act

Proposers acknowledge that TSTC is an agency of the State of Texas, and is therefore required to comply with the Texas Public Information Act (*Texas Government Code, Chapter 552.001, et seq.*) TSTC strictly complies with all statutes, court decisions, and opinions of the Texas Attorney General with respect to disclosure of public information. All information, documentation, and other materials submitted in response to this RFP are considered non-confidential and/or non-proprietary and are subject to public disclosure. If proposals include proprietary data, trade secrets, or information proposers must specifically label such data, secrets, or information as follows: "**PRIVILEGED AND CONFIDENTIAL – PROPRIETARY INFORMATION**".

1.17 Equal Opportunity

Proposer must be an equal opportunity employer. No person shall be discriminated against in employment because of race, color, religion, gender, national origin, disability, or age.

1.18 Accuracy of Information

The information presented in this RFP is complete and accurate to the best of TSTC's knowledge. If proposers have any questions in regards to this RFP, a written request should be submitted to Point of Contact before the Deadline for Written Questions specified herein.

1.19 Contract Award

Proposals to this RFP are offers to contract with TSTC. Proposals do not become contracts and are not binding until a written contract is executed by TSTC's delegated authority and awarded Proposer. Awarded Proposal will become incorporated by reference in the written contract. TSTC shall reserve the

right to award a contract for part or all requirements in the RFP, to award multiple awards, or not award any contract, according to what is in the best interest of the TSTC.

The RFP and submitted responsive documents, or portions of each, and at the College's sole discretion, may become incorporated by reference and a part of this written contract and will be binding on both the College and the Proposer after execution of the contract by both parties.

The term of this contract shall begin To Be Determined ("TBD") and terminate on August 31, 2022. At the end of the contract, TSTC has the option to continue services for an additional twenty-four (24) months by extending the termination date for a maximum of one year per renewal for two (2) additional consecutive renewal years. Either party may terminate this contract, without penalty, by giving 90 days written notice.

Initial Term: TBD to 08/31/2022

Fourth Optional Year: 09/01/2022 to 08/31/2023

Fifth Optional Year: 09/01/2023 to 08/31/2024

1.20 Ethics Conduct

Any direct or indirect actions taken to unduly influence competitive purposes, to circumvent equal consideration for competitive bidders, or to disregard ethical and legal trade practices will disqualify proposers from current and future consideration for participation in TSTC purchase orders and contracts.

SECTION 2: SCOPE OF WORK

2.1 Overview

This Scope of Services specifies the minimum requirements for the Contractor to provide and install a 10-inch fire loop around TSTC Campus in Sweetwater, Texas; including 5,200 linear feet of 10-inch PVC water lines, valves, fire hydrants and incidentals. Any additions to or differences from the minimum requirements for the Scope of Services requested shall be clearly identified in the Proposal response.

2.2 Scope of Work

TSTC is requesting proposals for a contractor to provide and install a 10-inch fire loop around the TSTC Campus in Sweetwater, Texas; including 5,200 linear feet of 10-inch PVC water lines, valves, fire hydrants and incidentals (“Project”), in accordance with the terms, conditions, and requirements set forth in this Request for Proposals (“RFP”). The Proposer is to supply all material, labor, and equipment and supervision required to perform the service.

2.3 Scope of Project

Refer to Attachment A – TSTC Fire Loop Specifications and Attachment B – Fire Loop Construction Drawings provided by Jacob Martin.

Drawings and specifications have been developed by Jacob Martin and are to be used for a complete scope of work. Work requirements will be defined by the contract documents, general conditions, supplemental and special conditions; and will include but not be limited to requirements for safety, badging and identification, training, site orientation/ campus rules, work hours, laydown and storage areas, parking areas, offices, SWPPP, construction water, security, etc.

2.4 TSTC Responsibilities:

Provide:

- TSTC Fire Loop Specifications. Refer to Attachment A
- Fire Loop Construction Drawings. Refer to Attachment B.

2.5 Contractor Minimum Responsibilities

The purpose of this request for Proposals (RFP) is to engage a Proposer to furnish materials, labor, and equipment required to complete this project in accordance with the drawings and specifications developed by Jacob Martin and made part of this RFP as Attachment A and Attachment B.

2.6 Mandatory Requirements/Conditions

- 2.6.1 Proposer(s) must have at least three (3) years of experience in providing Services in a commercial setting.
- 2.6.2 Proposer(s) must provide an SDS sheet for all chemicals used on campus.
- 2.6.3 Proposer(s) must provide written documentation to TSTC of each warranty within thirty (30) days after completion of Services.
- 2.6.4 Proposer(s) must provide proof of all required licenses and certifications.
- 2.6.5 Proposer(s) must perform all Services in accordance with the latest edition of the TSTC's Uniform General Conditions.
- 2.6.6 All employees of Proposer(s) performing Services on TSTC properties must wear uniforms or identification badges. No employee of the Proposer will be permitted on TSTC properties without proper identification.
- 2.6.7 Harassment: Under no circumstance will the University tolerate any form of verbal or non-verbal abuse, jeering, whistling, etc. directed toward College staff or students. The Proposer will be informed of any complaints and will be expected to permanently remove the problem employee from the job.
- 2.6.8 Smoking: All tobacco products, including smokeless tobacco, are prohibited on TSTC property at all times. This must be fully enforced by the Proposer.
- 2.6.9 Illegal Drugs and Alcohol: No alcoholic beverages or illegal drugs shall be brought on TSTC property at any time. Any workmen under the influence of either illegal drugs or alcohol or smelling of alcohol shall be permanently removed from the property by the Proposer.
- 2.6.10 Firearms/Weapons: Pursuant to Section 30.07 Penal Code, A person licensed under Subchapter H, Chapter 411, Government Code, may not enter any TSTC premises with a gun that is carried openly.
- 2.6.11 Restrooms: Under no conditions will any of the workmen be allowed to use restrooms within the existing College facilities except for the Physical Plant.
- 2.6.12 Proposer(s) must coordinate the execution of Services with TSTC.
- 2.6.13 Proposer(s) must include all costs related to providing the complete Services requested and reference the applicable contract number on all quotes.
- 2.6.14 TSTC will not be responsible for any Materials or Services not specifically detailed on the quote and approved through a formalized TSTC Purchase Order.
- 2.6.15 Proposer(s) must respond to notifications to plan and schedule Services within two (2)

business days of the initial request made by TSTC.

- 2.6.16 Proposer(s) must provide all necessary bonds and permits as required as defined in the UGC.

2.7 Preferred Requirements/Conditions

- 2.7.1 Proposer(s) should document their green initiative for providing responsible environmental practices.

2.8 Quality Measures

- 2.8.1 All Materials and Services delivered by Proposer(s) to TSTC are subject to inspection and approval by TSTC.
- 2.8.2 If for any reason TSTC is not satisfied with the Services, Proposer(s) must coordinate with TSTC to resolve the problem(s) with no additional charge, unless agreed upon in writing by TSTC.

2.9 Contract Administration

Contract Manager for this project is Spence Cates, Construction Project Manager.

2.10 Change or Addition to Scope of Services

TSTC, without invalidating the contract, may make changes by altering, adding to, or deduction from the Scope of Services at any time during the term of the contract in order to meet current TSTC needs. The Contract pricing shall be adjusted accordingly, upon mutual agreement between TSTC and Contractor.

Should TSTC request additional services during the term of the Contract, an agreement to provide these services at the same price as quoted will be understood as included in the Respondent's submission.

2.11 Group Purchasing Authority

Texas law authorizes institutions of higher education (defined by Section 61.003, Education Code) to use the group purchasing procurement method (Texas Education Code 51.9335). Additional Texas institutions of higher education may therefore elect to enter into a contract with the successful Proposer under this RFP. In particular, Proposer should note that Texas State Technical College is comprised of several campuses across the state of Texas described at <https://www.tstc.edu/campuses>. TSTC may routinely evaluate whether a contract resulting from a procurement conducted by one of the campuses might be suitable for use by another, and if so, this could give rise to additional purchase volumes. As a result, in submitting its proposal in response to this RFP, Proposer should consider proposing pricing and other commercial terms that take into account such higher volumes and other expanded opportunities that could result from the eventual inclusion of other institutions in the purchase contemplated by this RFP.

SECTION 3: PROPOSAL REQUIREMENTS

The Proposal must be organized in sections and divided by tabs in the following format and contain the following information and forms in Sections 3.1, 3.2, and 3.3. Respondents should note that elaborate or unnecessary voluminous proposals are not desired. All forms must be completed, signed, and returned as part of the Respondent's proposal.

3.1 Execution of Offer (TAB 1)

The Execution of Offer (Form A, Section 5) should be the first page of your Proposal. This form must be signed by a person authorized to sign for the Respondent.

3.2 Proposal Criteria (Each section should be in a separate tab)

Proposal Response (Tab 1) - Respondents to provide a detailed proposal in how the services will be provided. TSTC is interested in the approach, methods, and customer service that the firm will employ to provide the services.

Statement of Bidder's Qualifications (Tab 2): Refer to Attachment D.

Bid Schedule (Pricing) (Tab 3) –Bid prices must include all labor, material, equipment, insurance, overhead, superintendence, transportation, taxes, permits, profits, & incidentals to cover the finished work called for in this RFP. Refer to Attachment C.

Schedule (Timeline) (Tab 4) - Respondents are to provide a timeline for the Project schedule.

Project's teams' relative experience including sub-contractors on similar projects (Tab 5) - Provide resumes for the principal members of your organization, including the officers as well as the proposed superintendent for the project.

3.3 All Required Forms (Each form should be in a separate tab)

Form A: Execution of Offer [MUST BE SIGNED FOR RESPONSE TO BE ACCEPTED]

Form B: Deviation/Compliance Signature Form

Form C: Non-Collusion Statement

Form D: References

Form E: Inter-Local Agreement

Form F: HUB Sub-Contracting Plan [If proposal is over \$100,000, must be signed]

Form G: Conflict of Interest

Form H: Non-Bid Response [Optional]

SECTION 4: EVALUATION

Respondent is encouraged to propose terms and conditions offering the maximum benefit to TSTC in terms of (1) services to TSTC, (2) total overall cost to TSTC, and (3) expertise. Respondents should describe all educational, state and local government discounts, as well as any other applicable discounts that may be available to TSTC.

An evaluation team from TSTC will evaluate the Proposal. The evaluation of Proposal and the selection of a respondent will be based on the information provided by Respondent in its Proposal. TSTC may give consideration to additional information if TSTC deems such information relevant.

The criteria to be considered by TSTC in evaluating Proposal and selecting a Contractor will be those factors listed below.

Threshold Criteria Not Scored:

- Ability of TSTC to comply with laws regarding Historically Underutilized Businesses; and
- Ability of TSTC to comply with laws regarding purchases from persons with disabilities

Respondents shall carefully read the information contained in Section 4.1 and submit a complete statement of Proposals to all questions in Section 3.2. Incomplete Proposals will be considered non-responsive and subject to rejection.

Criteria to be Evaluated		Points
Criteria One:	Experience on similar projects	20
Criteria Two:	Schedule – Project Timeline	20
Criteria Three:	Project's Teams Relative Experience and Qualifications	20
Criteria Four:	Price	40

4.1 CRITERIA

TSTC may select the Proposal that offers the “best value” for the institution based on the published selection criteria and on its ranking evaluation. TSTC may first attempt to negotiate a contract with the selected respondent. TSTC may discuss with the selected respondent options for a scope or time modification and any price change associated with the modification. If TSTC is unable to reach a contract with the selected respondent, TSTC may formally end negotiations with that respondent and proceed to the next “best value” respondent in the order of the selection ranking until a contract is reached or all Proposals are rejected. TSTC is not obligated to select the Respondent offering the most attractive economic terms if that Respondent is not the most advantageous to TSTC overall, as determined by TSTC.

Best Value Criteria

- The quality, availability, and adaptability of the supplies, materials, equipment, or contractual services to the particular use required.
- The number and scope of conditions attached to the RFP.
- The ability, capacity, and skill of the proposer to perform the contract or provide the service required.
- Whether the proposer can perform the contract or provide the service promptly, or within the time required, without delay or interference.
- The character, responsibility, integrity, reputation, and experience of the proposer.
- The quality of performance of previous contracts or services;
- Any previous or existing noncompliance by the proposer with specification requirements relating to time of submission of specified data such as photos of equipment, samples, models, drawings, certificates, or other information; the sufficiency of the financial resources and ability of the proposer to perform the contract or provide the service;
- The ability of the proposer to provide future maintenance, repair parts, and service for the use of the contract.
- The purchase price:
- Any relevant criteria specifically listed in the RFP or request for proposals.

SECTION 5: FORMS

TSTC Requires that the Respondent complete and return the following forms as part of their proposal.

- FORM A: EXECUTION OF OFFER
<https://drive.google.com/a/tstc.edu/file/d/1-UJkKtKy9iq6nPcEqG2BehueicNtvku/view?usp=sharing>
- FORM B: DEVIATION/COMPLIANCE SIGNATURE FORM
<https://drive.google.com/a/tstc.edu/file/d/1-WxAWWAgz4MwsPirEr5JNljQlrhaoQEh/view?usp=sharing>
- FORM C: NON-COLLUSION STATEMENT
https://drive.google.com/a/tstc.edu/file/d/1-YRfnE-io4fwGGc4uxuQGF_mlhkm_YKd/view?usp=sharing
- FORM D: REFERENCES
<https://drive.google.com/a/tstc.edu/file/d/1-hkkeFTrZnQ0VgTKzNXW1m2hU3anw1Ve/view?usp=sharing>
- FORM E: INTERLOCAL AGREEMENT CLAUSE
<https://drive.google.com/a/tstc.edu/file/d/1-iSukTdfsLfBudN3bApB0W37JWmrN3rr/view?usp=sharing>
- FORM F: HUB SUBCONTRACTING PLAN
https://drive.google.com/a/tstc.edu/file/d/16PAaale7wTdYfoPg3987b7Rhdizqh_z3/view?usp=sharing
- FORM G: CONFLICT OF INTEREST
<https://drive.google.com/a/tstc.edu/file/d/1gA4flw76O4jYgKRpT6vIFzVwM-0PoB/view?usp=sharing>
- FORM H: NO BID RESPONSE (OPTIONAL)
https://drive.google.com/a/tstc.edu/file/d/1-ic7Duh8I2I8Danun_sQ6FQY5bix5mr3/view?usp=sharing

SECTION 6: ATTACHMENTS

ATTACHMENTS A – D: START ON NEXT PAGE.

- ATTACHMENT E: SAMPLE CONTRACT

THIS DOCUMENT IS A SAMPLE CONTRACT TEMPLATE TO BE USED AS AN INTRODUCTION TO COMMON TERMS FOUND IN THE TSTC CONSTRUCTION AGREEMENT TEMPLATE. THE ACTUAL CONTRACT WILL BE TAILORED TO FIT THE CIRCUMSTANCES. DO NOT FILL OUT OR SIGN THE SAMPLE CONTRACT TEMPLATE.

<https://drive.google.com/a/tstc.edu/file/d/11sBUrVDYvwPmHgJdbZlO7LcvJIW8o4ct/view?usp=sharing>

- ATTACHMENT F: STATE MAP

https://drive.google.com/a/tstc.edu/file/d/1-DEI4sg8hbjdtBi-mYno_ARTBuQ6nhM-/view?usp=sharing

Engineering Seal



These specifications were prepared by, overseen, reviewed and approved by, the following Texas Licensed Professional Engineer.

Henry Kirt Harle, PE No. 98381

Signature

8-22-19

Date

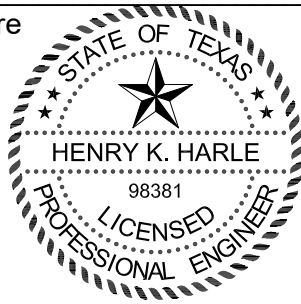

TABLE OF CONTENTS

DIVISION 01 - GENERAL REQUIREMENTS

01 00 01	DEFINITIONS AND TERMINOLOGY
01 01 01	SUMMARY OF WORK
01 02 01	SPECIAL TECHNICAL SPECIFICATIONS AND CONDITIONS
01 03 01	MEASUREMENT AND PAYMENT
01 04 01	SUBMITTALS
01 09 01	DISINFECTION OF POTABLE WATER PIPING AND TANKS

DIVISION 03 - CONCRETE

03 09 01	GENERAL CONCRETE
----------	------------------

DIVISION 31 - EARTHWORK

31 01 01	FLOWABLE FILL
31 03 01	TRENCHING, BACKFILLING AND COMPACTING
31 04 01	TRENCH EXCAVATION SAFETY PROTECTION SYSTEM
31 06 01	SITE GRADING AND EARTHWORK

DIVISION 33 - UTILITIES

33 01 01	GENERAL REQUIREMENTS FOR PIPING SYSTEMS
33 01 02	FIELD TESTING OF PIPING SYSTEMS
33 01 03	DUCTILE IRON PIPE
33 01 06	POLYVINYL CHLORIDE (PVC) PRESSURE PIPE
33 01 08	PIPE COUPLINGS AND EXPANSION JOINTS
33 02 04	GATE VALVES
33 05 01	BORE AND ENCASEMENT
33 06 01	MISCELLANEOUS WATER LINE MATERIALS

SECTION 01 00 01 - DEFINITIONS AND TERMINOLOGY

PART 1 GENERAL

1.1 ABBREVIATIONS

- A. Whenever any of the following abbreviations appear in these Specifications and Contract Documents, their meanings shall be as follows:
1. OWNER Texas State Technical College
 2. ENGINEER Jacob & Martin, LLC
 3. ASTM American Society for Testing Materials
 4. AWWA American Water Works Association
 5. AASHTO American Association of State Highway and Transportation Officials
 6. A.C. Asbestos Cement
 7. C.I. Cast Iron
 8. C.S. Commercial Standards
 9. D.I. Ductile Iron
 10. EPA Environmental Protection Agency
 11. GPM Gallons Per Minute
 12. NSF National Sanitation Foundation
 13. TDA Texas Department of Agriculture
 14. OSHA Occupational Safety and Health Administration
 15. PVC Polyvinyl Chloride
 16. TCDP Texas Community Development Program
 17. TCF Texas Capital Fund
 18. TXDOT Texas Department of Transportation
 19. TCEQ Texas Commission on Environmental Quality
 20. TWDB Texas Water Development Board
 21. USDA/RD United States Department of Agriculture - Rural Development

*Latest Revision

1.2 DOCUMENT ORGANIZATION

- A. Section GENERAL REQUIREMENTS govern the execution of all sections of the Specifications.
- B. Organization of Contract Documents is not intended to control or to lessen the responsibility of the Contractor in dividing work among his subcontractors, or in establishing extent of work to be performed by any trade.

1.3 SPECIFICATION SENTENCE STRUCTURE

- A. Specifications are written in modified brief style. Requirements indicated and specified apply to all work of same kind, class, and type even though word "all" is not stated.
- B. Simple imperative mood of sentence structure is used in Specification sections which places verb as first word sentence. Where such words as "perform", "provide", "install", "erect", "furnish", "connect", "test", or words similar import are used, it shall be understood that such words include meanings of phrase "The CONTRACTOR shall..." before each word.
- C. Standard paragraph titles and other identifications of subject matter in Specifications are intended as aid in locating and recognizing various requirements in the Specifications. Titles do not define, limit, or otherwise restrict Specification text. Capitalizing of words in text does not signify or mean that such words convey special or unique meanings that have precedence over other parts of the Contract Documents. Specification text shall govern over titling and shall be understood to be interpreted as a whole.

1.4 SPECIFICATION TERMINOLOGY

- A. Terms such as "directed", "designated", "requested", "authorized", "approved", "selected", or words of similar value shall mean by the Engineer unless otherwise stated. Use of these terms

does not extend the ENGINEERS's responsibility for construction supervision or responsibilities defined in the General conditions.

- B. "Required" and words of similar value mean as required to complete the work, unless otherwise stated.
- C. "Perform" shall mean CONTRACTOR, at his own expense, shall perform operations necessary to complete work.
- D. "Provide" shall mean CONTRACTOR, at his own expense, shall furnish and install work complete in place and ready to use.
- E. "Other acceptable manufacturer", "Approved equal", or words of similar meaning shall be understood to be followed by expression "in sole opinion of the ENGINEER" even though such words may not appear in print, unless otherwise stated.
- F. "Acceptance", "acceptable", or words of similar meaning shall mean acceptable to ENGINEER or OWNER. OWNER shall have jurisdiction and may override decisions of others.
- G. "At no extra cost to Owner", "With no extra compensation to CONTRACTOR", "At CONTRACTOR's own expense", or words of similar meaning shall be understood to mean the CONTRACTOR shall perform or provide specified operation of work at no increase to CONTRACTOR Sum in the executed Contract.
- H. "Indicated" refers to graphic representations, notes, or schedules on drawings, or other paragraphs or schedules in specifications, and similar requirements in Contract Documents. Where terms such as "shown", "noted", "scheduled" and "specified" are used, it is to help locate the reference; no limitation on location is intended except as specifically noted.
- I. "Accepted" where used in conjunction with ENGINEER's action on CONTRACTORS submittals, and requests, is limited to responsibilities and duties of ENGINEER. Such approval does not release CONTRACTOR from responsibility to fulfill Contract Document requirements.
- J. "Regulation" includes Federal, State and Local Laws, statutes, ordinances, and lawful orders issued by authorities have jurisdiction, as well as, rules, conventions, and agreements within construction industry that control performance of work, whether they are lawfully imposed by authorities having jurisdiction or not.
- K. "Furnish" is used to mean to supply and deliver to project site, ready for unloading, unpacking, assembly, installation, and similar operation.
- L. "Install" is used to describe operations at project site including actual unloading, unpacking, assembly, erection, placing, anchoring, applying, working to dimension, finishing, curing, protecting, cleaning, and similar operations.
- M. "Installer" is an entity engaged by CONTRACTOR, either as an employee, subcontractor, or sub-subcontractor for performance of particular construction activity, including installation, erection, application, and similar operations. Installers are required to be experienced in the operations they are engaged to perform.
- N. The term "experienced", when used with the term "installer", means having minimum five (5) previous projects similar in size and scope to this project, and familiar with precautions required, and has complied with requirements of authority having jurisdiction.
- O. "Project site" is the space available to the CONTRACTOR for performance of work, either exclusively or in conjunction with others performing construction as part of the project.
- P. "Testing Laboratory" is an independent entity engaged to perform specific inspections or test, either at the project site or elsewhere, and to report on, or to interpret results of those inspections or tests as required. Unless otherwise indicated, testing laboratories shall be hired by the CONTRACTOR at no additional cost to the OWNER.
- Q. Equipment is "Listed" if of a kind mentioned in a list which:
 - 1. Is published by a nationally recognized laboratory which makes periodic inspection of production of such equipment.
 - 2. States that such equipment meets nationally recognized standards or has been tested and found safe for use in a specified manner.
- R. Equipment is "Labeled" if:
 - 1. It embodies a valid label, symbol, or other identifying mark of a nationally recognized testing laboratory such as Underwriters Laboratories, Inc.

2. Production is periodically inspected in accordance with nationally recognized standards or tests to determine safe use in a specified manner.
- S. Equipment is "Certified" if:
 1. Equipment has been tested and found by a nationally recognized testing laboratory to meet nationally recognized standards or to be safe for use in a specified manner.
 2. Production is periodically inspected by a nationally recognized testing laboratory.
 3. It bears a label, tag, or other record of certification.

1.5 REFERENCE STANDARDS

- A. Applicable construction industry standards have the same force and effect as if bound or copied directly into the Contract Documents regardless of lack of reference within the Contract Documents. Where Contract Documents include more stringent requirements than the reference standards, the Contract Documents shall apply.
 1. Standards referenced directly in the Contract documents take precedence over standards that are not referenced but recognized in the construction industry as applicable.
 2. Except as otherwise limited by the Contract Documents, enforce standards not referenced but recognized in industry as applicable for performance of the work. The ENGINEER shall decide whether code or standard is applicable, or which of several are applicable.
- B. Consider a reference standard to be the latest edition with supplements or amendments when standard is referred to in an individual Specification Section but is not listed by the title and date.
- C. Maintain copies of reference standards at project site throughout construction period. Make copies of reference standards available as requested by ENGINEER or OWNER.
- D. Enforce the most stringent requirements where compliance with two (2) or more standards is specified, and they establish different or conflicting requirements for minimum quantities or quality levels, unless Contract Documents indicate otherwise.
 1. Quantity or quality level shown or indicated shall be minimum to be provided or performed in every instance.
 2. Actual installation may comply exactly with minimum quality indicated, or it may exceed that minimum within reasonable limits.
 3. In complying with these requirements, indicated numeric values are minimum or maximum values, as noted, or appropriate for context of requirements.
 4. Refer instances of uncertainty to the Engineer for decision before proceeding.
- E. Trade association names and titles of general standards are frequently abbreviated. Where acronyms or abbreviations are used in specifications or other Contract Documents they mean recognized name of trade association, standards generating organization, authority having jurisdiction, or other entity applicable to context of text provision. Refer to "Encyclopedia of Associations", published by Gale Research Company.

PART 2 NOT USED

PART 3 NOT USED

-- END OF SECTION --

SECTION 01 01 01 - SUMMARY OF WORK

PART 1 GENERAL

1.1 WORK INCLUDED

- A. Construct work as described in the Contract Documents.
 - 1. Provide materials, equipment, and incidentals required to make the project completely operable.
 - 2. Provide the labor, equipment, tools, and consumable supplies required for a complete project.
 - 3. Provide the civil, architectural, structural, mechanical, electrical, instrumentation and all other work required for a complete and operable project.
 - 4. Test and place the completed project in operation.
 - 5. Provide the special tools, spare parts, lubricants, supplies, or other materials as required for the operation and maintenance of the Project.
 - 6. Drawings and Specifications may not indicate or describe all of the work required to complete the project. Additional details required for the completion of the project are to be provide by the CONTRACTOR and coordinated with the ENGINEER.

1.2 JOB CONDITIONS

- A. The General Conditions, the Special Conditions, and Division One Specifications apply to each Specification section.
- B. Comply with all applicable federal, state and local codes and regulations pertaining to the nature and character of the work being performed.

1.3 DESCRIPTION OF WORK

- A. The project includes the installation of a fire loop around the TSTC Sweetwater Campus including approximatley 5,200 linear feet of 10-inch PVC water lines, fire hydrants, valves, pavement repair and incidentals.

1.4 TIME OF COMPLETION

- A. The time to be allowed under this Contract to complete all work is as included in the proposal by the Contractor. Work time established allows for the normal delays associated with bad weather, etc. and shall begin ten (10) days after the issuance of the Notice to Proceed by the OWNER. Requests for extension to time of completion shall be made by the CONTRACTOR to the ENGINEER, in writing, on a monthly basis corresponding with the submission of a partial payment requests. Requests for time extensions received more than 60 days following a requested date will not be considered.

1.5 SCHEDULE AND SEQUENCE OF CONSTRUCTION

- A. Within 10 days prior to submission of the first partial payment request, the CONTRACTOR shall submit to the ENGINEER for approval six copies of the schedule under which the CONTRACTOR proposes to complete the project.
- B. If, in the opinion of the ENGINEER, construction progress falls behind the schedule, the CONTRACTOR shall take such action as necessary to improve his progress, and the CONTRACTOR shall submit to the ENGINEER a revised schedule demonstrating his proposed plan to make up the lag in scheduled progress and complete the project within the contract time.

1.6 WORK BY OWNER

- A. The OWNER may perform items of work which are not included in this Contract, but may impact construction scheduling. CONTRACTOR to coordinate construction activities through the ENGINEER.

1.7 CONSTRUCTION OF UTILITIES

- A. Coordinate with Utility Companies or their contractors to provide all required utilities for this project. Construction of permanent utilities will be paid for by the OWNER.
- B. Power and Electrical Services

1. Pay for temporary construction power, including but not limited to construction cost, meter connection, fees and permits.

1.8 OCCUPANCY

- A. As soon as any portion of the Project is ready to use, the OWNER shall have the right to operate the portion upon written notice to the CONTRACTOR.
- B. Testing of Controls, including specified test periods, training, and start-up does not constitute acceptance for operation.
- C. OWNER may accept the facility for continued use after start-up and testing at the option of the OWNER. If acceptance is delayed at option of the OWNER, shut down facilities per approved Operation and Maintenance procedures.
- D. The execution of bonds is understood to indicate the consent of surety.
- E. Conduct operations to insure the least inconvenience to the OWNER and general public.

PART 2 PRODUCTS

2.1 MATERIALS

- A. Provide materials and products per the individual sections of the Specifications.

PART 3 EXECUTION

3.1 NOT USED

-- END OF SECTION --

SECTION 01 02 01 - SPECIAL TECHNICAL SPECIFICATIONS AND CONDITIONS

PART 1 GENERAL

1.1 PRIORITY OF INTERPRETATION

- A. The Contract Documents are complementary, and what is called for by one document shall be binding as if called for by all. In case of conflict between any of the Contract Documents, priority of interpretation shall be in the following order:
 - 1. TSTC 2012 Uniform General Conditions and Supplementary General Conditions
 - 2. Agreement
 - 3. Performance and Payment Bonds, if required
 - 4. Special Bonds, if any
 - 5. Proposal / Bid
 - 6. Special Technical Specifications and Conditions
 - 7. Plans
 - 8. Technical Specifications

1.2 METHODS OF OPERATION

- A. The CONTRACTOR shall inform the ENGINEER in advance concerning his plans for carrying on each part of the work, but the CONTRACTOR alone shall be responsible for safety, adequacy, and efficiency of his plant, equipment, and methods.
- B. The OWNER and ENGINEER will not be responsible for any act or omission of the CONTRACTOR, or any subcontractor, or any of the agents or employees, or any other persons performing any of the work. The OWNER and ENGINEER will not be responsible for any failure of the CONTRACTOR or his subcontractors or any other persons to perform the work in accordance with the requirements of the contract documents.
- C. Review by the OWNER or ENGINEER of any plan or method of work proposed by the CONTRACTOR shall not relieve the CONTRACTOR of any responsibility therefore, and such review shall not be considered as an assumption of any risk or liability by the OWNER or ENGINEER, or any officer, agent, or employee thereof.

1.3 WORKMANSHIP

- A. These specifications contain detailed instructions and descriptions covering the major items of construction and workmanship necessary to construct the above mentioned project. The specifications are intended to be so written that only first class workmanship and finish of the best grade and quality will result. The fact that these specifications may fail to be so complete as to cover all details will not relieve the CONTRACTOR of full responsibility for providing a completed project of high quality, first class finish and appearance and satisfactory for operation, all within the apparent intent of the plans and specifications.

1.4 ESTIMATED QUANTITIES

- A. The Contract Documents are intended to show clearly all work to be done and materials to be furnished. Where the estimated quantities are shown for the various classes of work to be done and material to be furnished under this contract, they are approximate and are to be used only as a basis for estimating the probable cost of the work and for comparing the proposals offered for the work. It shall be understood that the actual amount of work to be done and material to be furnished under this contract may differ from these estimates, and where the basis for payment under this contract is the unit price method, payment shall be for the actual amount of such work and material furnished.
- B. Where payment is based on the unit price method, the CONTRACTOR agrees that he will make no claim for damages, anticipated profits or otherwise on account of any differences which may be found between the quantities of work actually done, the material actually furnished under this contract and the estimated quantities contemplated and contained in the proposal. However, in case the actual quantity of any major item becomes as much as 25% more than or 25% less than the estimated or contemplated quantity for such item, then either party to this Agreement, upon demand, shall be entitled to a revised consideration upon the portion of the work above or below 25% of the estimated quantity. The OWNER will not pay for increased material prices for

any quantity increase within the 25% allowable. Therefore, the CONTRACTOR should endeavor to have his material quote cover up to 25% more than the bid quantity.

- C. A "Major Item" shall be construed to be any individual bid item included in the proposal that has a total cost equal to or greater than 25% of the total contract cost, computed on the basis of the proposal quantities and contract unit prices. Any revised consideration is to be determined by Agreement between the parties, otherwise by terms of the Agreement, as provided under Changes in Contract Price in the General Conditions.

1.5 FINAL QUANTITIES INSTALLED

- A. Should there be a discrepancy between the CONTRACTOR'S claim for quantity of materials installed and the quantity measured by the ENGINEER, the discrepancy may be resolved as follows:
 1. The plans shall be thoroughly checked by the ENGINEER and CONTRACTOR to assure that all changes in work have been recorded and no errors exist in the material take-off.
 2. Should the quantity discrepancy not be resolved by means of plan sheet examination, then at the CONTRACTOR'S request, segments of lines may be re-measured: however, if the CONTRACTOR'S figures are not proven to be accurate by re-measurement, then the CONTRACTOR shall pay for cost of re-measurement.
 3. Any deviations in straight-line routing of pipeline not approved by the ENGINEER and/or OWNER shall be paid only for the footage of pipe which would have been required for a straight line installation.

1.6 PROTECTION OF LIVES AND PROPERTY

- A. In order to protect the lives and health of his employees, the CONTRACTOR shall comply with all pertinent provisions of the "Manual of Accident Prevention in Construction" issued by the Associated General CONTRACTOR of America, Inc. The CONTRACTOR shall maintain an accurate record of all cases of death, occupational disease and injuries requiring medical attention or causing loss of time from work arising out of and in the course of work under this contract. The CONTRACTOR alone shall be responsible for the safety, efficiency and adequacy of his plant, appliances and methods and for any damage which may result from their failure, improper construction, maintenance or operation.

1.7 SANITARY FACILITIES

- A. The CONTRACTOR shall provide adequate toilet facilities for use by workmen in accordance with O.S.H.A. provisions, and shall maintain such facilities throughout the construction period.

1.8 EXISTING UTILITIES

- A. It shall be the entire responsibility of the CONTRACTOR to locate all existing underground utilities ahead of the work, whether or not shown on the Plans, and to protect and preserve such utilities from any damage from the proposed construction operations. In the event an underground water, oil, gas, telephone line, or other utility is damaged, the respective OWNER of said utility shall be notified immediately by the CONTRACTOR. It shall be the CONTRACTOR'S entire responsibility to see that said utilities are repaired to the satisfaction of the ENGINEER and utility OWNER. If the CONTRACTOR shows a complete disregard for existing utilities, the CONTRACTOR will pay the OWNER, \$1,000 per occurrence in addition to paying all costs for repairing damage to existing utilities. Continued disregard for existing utilities may result in suspension or termination of the Construction Contract. Where overhead poles or anchors are encountered, or are necessary to be disturbed or moved, the CONTRACTOR shall contact the OWNER of the utility and arrange to have the necessary adjustments made, at no additional cost to the OWNER. When signs are disturbed or damaged, the CONTRACTOR shall restore them to the same or better condition that existed prior to construction.

1.9 SATURDAY AND SUNDAY WORK

- A. Construction work on Saturdays or Sundays will not be permitted on the project except to maintain barricades, warning signs and flares. In the event the CONTRACTOR is prevented from working on the project for two or more days in any one calendar week, he may work the following Saturday if approval is given by the ENGINEER and OWNER.

1.10 TPDES GENERAL PERMIT

- A. The CONTRACTOR shall fully comply with the Texas Pollutant Discharge Elimination System Permit TXR 150000. All construction activities shall fully comply with all aspects of this permit, and the CONTRACTOR shall certify to the OWNER said compliance before the certificate of construction completion is issued. The CONTRACTOR shall apply for and obtain the permit before construction. The CONTRACTOR shall be responsible for the permit fee and all other costs associated with the referenced permit.
- B. At least three (3) days before commencement of construction, the CONTRACTOR shall file a Notice of Intent (NOI) with the TCEQ. The notice shall be sent to the TCEQ, Storm Water & Processing Center: MC-228, P.O. Box 13087, Austin, Texas 78711-3087. One copy of the NOI shall be sent to the ENGINEER and one copy shall be posted at the site. The NOI form and permit requirement may be obtained from the TCEQ or on their website www.tceq.state.tx.us The CONTRACTOR shall prepare a Stormwater Pollution Prevention Plan (SWPPP), obtain, and fully comply with the Texas Pollutant Discharge Elimination System Permit TXR 150000. Questions concerning this permit may be addressed to TCEQ at 512-239-3700.

1.11 CONSTRUCTION SURVEYING

- A. The construction surveying described in Paragraph 1 below shall be provided by the OWNER. The surveying work contained in Paragraphs 2, 3, and 4 shall be considered subsidiary to the overall project and no separate payment shall be made for this work. Work contained in Paragraphs 2, 3, and 4 shall be accomplished by the CONTRACTOR.
 - 1. The surveyor shall obtain copies of all private property easements, and public right of way permits. From these easements and permits, the surveyor shall set alignment lathes, stakes, and hubs as needed and benchmarks as needed, plus alignment stakes at every horizontal PI. Also, alignment lathes, stakes, and hubs shall be set at every property line or ROW line crossing. The CONTRACTOR shall notify the ENGINEER at least 24 hours before each segment is to be staked. Each segment to be staked shall be a minimum of 1000 feet in length. Staking will be provided one time only. Stakes that are lost or damaged shall be replaced by the CONTRACTOR at his own cost.
 - 2. Locate and protect control points prior to starting the site work and preserve permanent reference points during construction. The CONTRACTOR shall not change or relocate points without prior approval of the ENGINEER. Notify ENGINEER when the reference point is lost, destroyed, or requires relocation. Replace project control points on the basis of the original survey.
 - 3. Provide complete engineering layout of the work needed for construction.
 - a. Provide competent personnel. Provide equipment including accurate surveying instruments, stakes, platforms, tools, and materials.
 - b. Record data and measurements per standards.
 - 4. Construction lines and grades, as well as base lines and bench marks provided by the CONTRACTOR, shall be subject to such checks and reviews as the ENGINEER may, from time to time, desire to make.

1.12 WATER USED DURING CONSTRUCTION PERIOD

- A. The CONTRACTOR shall pay to the City of Sweetwater, the standard construction water rate per thousand gallons for all water used for filling the lines, flushing, testing, leaks, etc.

1.13 UTILITIES DURING CONSTRUCTION

- A. The CONTRACTOR will be required to make arrangements for and pay for the electrical power and any other utilities required during construction.

1.14 STATE HISTORIC PRESERVATION

- A. If cultural materials are encountered during construction, work must cease in the immediate area. Work can continue in the project area where no cultural materials are present. The Secretary of Interior (202-343-4101) must be contacted in accordance with 36 CFR 8007. Also, the State Historic Preservation Officer (512-463-6100) must be notified.

1.15 UNCLASSIFIED EXCAVATION

- A. All excavation on this project will be considered to be unclassified, and no extra payment will be made for the removal of any rock, shale, roots and any other material or substance that may be encountered in the construction work as set out on the Drawings and in the Technical Specifications.

1.16 ROCK EXCAVATION

- A. In all areas requiring rock excavation, the Contractor shall install the pipe and complete the "rock free" bedding so that the installation may be inspected prior to backfilling. The Owner's inspector shall be notified by the Contractor when the bedding is complete for each particular segment. Any rock excavation areas backfilled without the Owner's prior inspection will require uncovering and checking at the Contractor's expense.

1.17 LOCATION OF PIPELINES

- A. In the event pipeline locations required by the Plans should intersect a septic tank drain field or animal pens where extreme pollution might occur, the CONTRACTOR shall notify the ENGINEER and OWNER, and proposed water pipeline shall be re-routed in order to avoid such areas of possible pollution. In the event additional lengths of pipeline are required, the additional lengths will be paid for at the unit price bid per linear foot as set out in the proposal. No unauthorized straight line deviations will be paid for. The CONTRACTOR shall fully comply with TCEQ chapter 290.44(3) and Chapter 317.13 Appendix E for location of water/sewer lines and separation distances. No extra payment will be made to the CONTRACTOR for compliance with TCEQ requirements.

1.18 LOCATION OF VALVES AND METERS

- A. Valves, meters, meter boxes and vaults shall be installed at the locations shown on the Plans.
 - 1. Whenever possible, valves shall be located adjacent to existing fences or edge of the right-of-way especially in cultivated fields. Unless absolutely necessary, valves shall not be located in borrow ditches or wash-out areas. The CONTRACTOR shall install two 4" diameter steel pipes (7'), buried 3 feet with concrete and painted for all valves located in cultivated fields at no additional cost to the OWNER.
 - 2. The meters shall be centered in the boxes, vaults to allow for reading and ease of removal or maintenance. No boring or taps shall be made for meter installation unless the OWNER has previously designated the exact location for the meter.

1.19 CONSTRUCTION ON COUNTY OR CITY RIGHT-OF-WAY

- A. The OWNER has received authorization from the County authorizing pipeline construction in County road right-of-way in the locations indicated on the Plans. It shall be the CONTRACTOR'S entire responsibility to notify the appropriate Precinct Commissioner 48 hours prior to any construction work on County right-of-way, and conduct construction operations in full cooperation with Precinct Commissioner.
- B. Where necessary to cross a county road or install pipeline within the County road riding surface, all ditch backfilling shall be as noted or required per County Precinct Commissioner, base material replaced as directed by the Precinct Commissioner, and the road left in a condition equal to that prior to crossing. In areas where pavements exists or where new construction is being proposed, and the County Commissioner requires the crossing to be bored, the CONTRACTOR shall bore and encase the pipeline in the same manner required by the Texas Highway Department for highway crossings and payment will be made at the unit price bid for Bore and Encasement as set out in the Bid Schedule. All paved county roads shall be bored. No paved county road shall be open cut unless written approval is obtained from the appropriate Precinct Commissioner.
- C. All County road crossings or paralleling in County right-of-way shall have right-of-way markers installed at the entrance and exit points and a detectable metal tape shall be installed in the pipeline ditch while in the County right-of-way.

1.20 WATER LINE PARALLELING OR CROSSING SEWER LINES

- A. The Contractor shall fully comply with all Texas Commission on Environmental Quality regulations pertaining to separation distances as described in Table I of this section. No additional payment shall be made for separation distance compliance, but this work shall be considered subsidiary to the overall project.
- B. Location of waterlines. The following rules apply to installations of waterlines, wastewater mains or laterals, and other conveyances/appurtenances identified as potential sources of contamination. Furthermore, all ratings specified shall be defined by ASTM or AWWA standards unless stated otherwise. New mains, service lines, or laterals are those that are installed where no main, service line, or lateral previously existed, or where existing mains, service lines, or laterals are replaced with pipes of different size or material.
 - 1. When new potable water distribution lines are constructed, they shall be installed no closer than nine feet in all directions to wastewater collection facilities. All separation distances shall be measured from the outside surface of each of the respective pieces.
 - 2. Potable water distribution lines and wastewater mains or laterals that form parallel utility lines shall be installed in separate trenches.
 - 3. No physical connection shall be made between a drinking water supply and a sewer line. Any appurtenance shall be designed and constructed so as to prevent any possibility of sewage entering the drinking water system.
 - 4. Where the nine-foot separation distance cannot be achieved, the following criteria shall apply.
- C. New waterline installation - parallel lines.
 - 1. Where a new potable waterline parallels an existing, non-pressure or pressure rated wastewater main or lateral and the licensed professional engineer licensed in the State of Texas is able to determine that the existing wastewater main or lateral is not leaking, the new potable waterline shall be located at least two feet above the existing wastewater main or lateral, measured vertically, and at least four feet away, measured horizontally, from the existing wastewater main or lateral. Every effort shall be exerted not to disturb the bedding and backfill of the existing wastewater main or lateral.
 - 2. Where a new potable waterline parallels an existing pressure rated wastewater main or lateral and it cannot be determined by the licensed professional engineer if the existing line is leaking, the existing wastewater main or lateral shall be replaced with at least 150 psi pressure rated pipe. The new potable waterline shall be located at least two feet above the new wastewater line, measured vertically, and at least four feet away, measured horizontally, from the replaced wastewater main or lateral.
 - 3. Where a new potable waterline parallels a new wastewater main, the wastewater main or lateral shall be constructed of at least 150 psi pressure rated pipe. The new potable waterline shall be located at least two feet above the wastewater main or lateral, measured vertically, and at least four feet away, measured horizontally, from the wastewater main or lateral.
- D. New waterline installation - crossing lines.
 - 1. Where a new potable waterline crosses above a wastewater main or lateral, the segment of the waterline pipe shall be centered over and must be perpendicular to the wastewater main or lateral such that the joints of the waterline pipe are equidistant and at least nine feet horizontally from the centerline of the wastewater main or lateral. When crossing an existing wastewater main or lateral and it is disturbed or shows signs of leaking, the wastewater main or lateral shall be replaced for at least nine feet in both directions (18 feet total) with at least 150 psi pressure-rated pipe embedded in cement stabilized sand (see clause (v) of this subparagraph) for the total length of one pipe segment plus 12 inches beyond the joint on each end.
 - a. The potable waterline shall be at least two feet above an existing, non-pressure rated wastewater main or lateral.
 - b. The potable waterline shall be at least six inches above an existing, pressure-rated wastewater main or lateral.

2. Where a new potable waterline crosses a new, non-pressure rated wastewater main or lateral, the segment of the waterline pipe shall be centered over and shall be perpendicular to the wastewater main or lateral such that the joints of the waterline pipe are equidistant and at least nine feet horizontally from the centerline of the wastewater main or lateral. The potable waterline shall be at least two feet above the wastewater main or lateral. Whenever possible, the crossing shall be centered between the joints of the wastewater main or lateral. The wastewater pipe shall have a minimum pipe stiffness of 115 psi at 5.0% deflection. The wastewater main or lateral shall be embedded in cement stabilized sand (see clause (v) of this subparagraph) for the total length of one pipe segment plus 12 inches beyond the joint on each end. The materials and method of installation shall conform to one of the following options:
 - a. Within nine feet horizontally of either side of the waterline, the wastewater pipe and joints shall be constructed with pipe material having a minimum pressure rating of at least 150 psi. An absolute minimum vertical separation distance of two feet shall be provided. The wastewater main or lateral shall be located below the waterline.
 - b. All sections of wastewater main or lateral within nine feet horizontally of the waterline shall be encased in an 18-foot (or longer) section of pipe. Flexible encasing pipe shall have a minimum pipe stiffness of 115 psi at 5.0% deflection. The encasing pipe shall be centered on the waterline and shall be at least two nominal pipe diameters larger than the wastewater main or lateral. The space around the carrier pipe shall be supported at five-foot (or less) intervals with spacers or be filled to the discrepancies with washed sand. Each end of the casing shall be sealed with watertight non-shrink cement grout or a manufactured watertight seal. An absolute minimum separation distance of six inches between the encasement pipe and the waterline shall be provided. The wastewater line shall be located below the waterline.
 3. When a new waterline crosses under a wastewater main or lateral, the waterline shall be encased as described for wastewater mains or laterals in clause (ii) of this subparagraph or constructed of ductile iron or steel pipe with mechanical or welded joints as appropriate. An absolute minimum separation distance of one foot between the waterline and the wastewater main or lateral shall be provided. When a new waterline crosses under a wastewater main, the procedures in §217.53(d) of this title (relating to Pipe Design) must be followed.
 4. Where a new potable waterline crosses a new, pressure rated wastewater main or lateral, one segment of the waterline pipe shall be centered over and shall be perpendicular to the wastewater line such that the joints of the waterline pipe are equidistant and at least nine feet horizontally from the center line of the wastewater main or lateral. The potable waterline shall be at least six inches above the wastewater main or lateral. Whenever possible, the crossing shall be centered between the joints of the wastewater main or lateral. The wastewater pipe shall have a minimum pressure rating of at least 150 psi. The wastewater main or lateral shall be embedded in cement stabilized sand (see clause (v) of this subparagraph) for the total length of one pipe segment plus 12 inches beyond the joint on each end.
 5. Where cement stabilized sand bedding is required, the cement stabilized sand shall have a minimum of 10% cement per cubic yard of cement stabilized sand mixture, based on loose dry weight volume (at least 2.5 bags of cement per cubic yard of mixture). The cement stabilized sand bedding shall be a minimum of six inches above and four inches below the wastewater main or lateral. The use of brown coloring in cement stabilized sand for wastewater main or lateral bedding is recommended for the identification of pressure rated wastewater mains during future construction.
- E. Waterline and wastewater main or lateral manhole or cleanout separation. The separation distance from a potable waterline to a wastewater main or lateral manhole or cleanout shall be a minimum of nine feet. Where the nine-foot separation distance cannot be achieved, the potable waterline shall be encased in a joint of at least 150 psi pressure class pipe at least 18 feet long and two nominal sizes larger than the new conveyance. The space around the carrier pipe shall be supported at five-foot intervals with spacers or be filled to the springline with washed sand.

The encasement pipe shall be centered on the crossing and both ends sealed with cement grout or manufactured sealant.

- F. Location of fire hydrants. Fire hydrants shall not be installed within nine feet vertically or horizontally of any wastewater main, wastewater lateral, or wastewater service line regardless of construction.
- G. Location of potable or raw water supply or suction lines. Suction mains to pumping equipment shall not cross wastewater mains, wastewater laterals, or wastewater service lines. Raw water supply lines shall not be installed within five feet of any tile or concrete wastewater main, wastewater lateral, or wastewater service line.
- H. Proximity of septic tank drainfields. Waterlines shall not be installed closer than ten feet to septic tank drainfields.

1.21 TRENCH SETTLEMENT

- A. The CONTRACTOR shall be responsible for all settlement of backfill, fills, and embankments which may occur within one (1) year after final completion of the contract under which the work was performed.
- B. The CONTRACTOR shall make, or cause to be made, all repairs or replacements made necessary by settlement, within thirty (30) days after notice from the ENGINEER or OWNER.

1.22 RESTORATION OF SURFACES

- A. The CONTRACTOR shall replace all surface material (including topsoil in original thickness), and shall restore gravel drives and roadways, fencing, sod and other surfaces disturbed, to a condition equal to that before the work began, furnishing all labor and material incidental thereto.

1.23 SURPLUS EARTH

- A. Surplus excavated materials from all trenching, manholes, and structures shall be disposed of by the CONTRACTOR as approved by the OWNER and ENGINEER.

1.24 CONCRETE BLOCKING

- A. All bends, tees, etc., 2" and larger shall be blocked with concrete per the Plans and Specifications with a minimum soil bearing surface of 1.0 square foot per inch diameter of pipe. The use of rocks, masonry blocks, etc. is not acceptable. Only "Sacrete" which has been thoroughly mixed or Class B concrete shall be used for blocking. No blocking shall be covered up until it has been inspected and approved by the OWNER and/or ENGINEER. If covered prior to inspection, the CONTRACTOR shall uncover the blocking for inspection at his expense.

1.25 FENCES AND SIGNS

- A. When necessary for the CONTRACTOR to take down signs, fences or other obstructions, this shall be done at his own expense and replaced in the original condition after construction operations. Fences which are taken loose by the Contractor shall be done in a manner to prevent slacking of the remainder of the wire. The CONTRACTOR, prior to taking down any fence shall have complete approval of the Project Representative as to the width of the fence gap to be made and the manner in which existing posts are to be placed. **No fences shall be cut without authorization in writing from OWNER or ENGINEER.**

1.26 BARRICADES, WARNING SIGNS AND PUBLIC CONVENIENCE

- A. The convenience of access of the adjoining property OWNERS on the streets herein scheduled for improvements is of prime importance in the construction operations. In certain locations it may be necessary that property OWNERS use a portion of the roadway being improved to access their property. In such cases, the CONTRACTOR shall schedule his operations to provide such access to the property OWNERS in a safe and convenient manner. The CONTRACTOR shall provide courteous, English speaking and well informed flagmen for directing traffic. Flagmen shall wear a bright red coat and shall use a bright red flag to signal traffic.
- B. At each section of street and each cross street intersecting the section of street under construction, the CONTRACTOR shall provide barricades and other warning signs as necessary. Detour signs shall be placed at all intersections where traffic is diverted from the

section under construction and at other intersections of the detour to provide complete directions for detouring traffic around the section under construction. CONTRACTOR shall also provide any necessary special signs to signify any hazards or conditions. All barricades, detour and warning signs that remain in place at night shall be fully lighted by approved methods from sunset to sunrise. All signs shall be kept in a good state of repair and be plainly legible at all times. Upon completion of the project, all signs and evidence thereof shall be completely removed from the site of the work by the CONTRACTOR.

1.27 CLEARING AND CLEAN UP

- A. All necessary clearing shall be done by the CONTRACTOR. All tree branches, limbs and roots shall be removed and disposed of by the CONTRACTOR in order that the right-of-way may be left in a neat and presentable condition. Any damage resulting to trees, grass and shrubbery must be paid for, by the CONTRACTOR, and damage claims, if any, settled by the CONTRACTOR.
- B. Prior to final acceptance of the project, the CONTRACTOR shall clean and smooth up the site of the work and remove all rock, debris, material, etc., leaving the project site with a neat appearance to the satisfaction of the OWNER. Disposed of debris, rubbish, etc. shall be made in an area which shall meet the approval of the OWNER and ENGINEER. The CONTRACTOR shall comply fully with all applicable EPA and TCEQ regulations.

1.28 START UP AND OPERATION

- A. Prior to presentation for final acceptance of the work under this contract, the CONTRACTOR shall have started and operated all units at each site for a sufficient duration of time, thirty (30) days to permit the OWNER and ENGINEER to observe overall performance of the respective units and equipment.
- B. Such operation shall be properly coordinated with the OWNER'S operating personnel.

1.29 FEDERAL AND/OR STATE AGENCY'S APPROVAL AND INSPECTION

- A. The written approval of the appropriate state agency having jurisdiction over the facility must be secured prior to payment of the final percentage retained under this contract.
- B. The project site and premises as well as any records required shall be available at all reasonable times for inspection by authorized representatives of the State or Federal Agencies having jurisdiction over the project. The CONTRACTOR shall provide all necessary facilities for these inspections.

1.30 "RECORD DRAWING" INFORMATION

- A. The CONTRACTOR shall be responsible for recording and providing all information concerning changes from the original plans as to valve, meter, and/or pipeline location for transfer to the "As-Built" or "Record Drawings" Plans. Final payment will not be released until "Record Drawings" are approved by the ENGINEER.

1.31 AFFIDAVIT OF BILLS PAID

- A. Prior to final acceptance of the project by the OWNER, the CONTRACTOR shall execute a Release by Claimants and an affidavit which states all bills for labor, materials and incidentals incurred in the construction of the project have been paid in full and that there are no claims pending of which he has been notified.

PART 2 NOT USED

PART 3 NOT USED

-- END OF SECTION --

SECTION 01 03 01 - MEASUREMENT AND PAYMENT

PART 1 PAYMENT ITEMS

1.1 UNIT PRICE PAYMENT ITEMS

- A. Payment items for the work of this contract on which the contract unit price payments will be made are listed in the BIDDING SCHEDULE and described below. The unit price and payment made for each item listed shall constitute full compensation for furnishing all plant, labor, materials, and equipment, and performing any associated Contractor quality control, environmental protection, meeting safety requirements, tests and reports, and for performing all work required for each of the unit price items.

1.2 WATER LINE

A. PAYMENT

Payment will be made for costs associated with operations necessary to furnish and install water line as specified and shown on the Plans. Water pipelines shall be measured and paid for at the unit prices for each size and class of water pipeline, which payment shall include trenching, laying, bedding, jointing, backfilling, connection to or plugging of existing water lines and furnishing water pipelines, fittings, couplings and accessories as specified, including labor, equipment, testing, sterilization, cleanup and supervision necessary to complete the water pipeline and place the water system in operation in accordance with these Specifications and may be directed by the ENGINEER.

No extra payment shall be made for special backfill in public ROW or gravel repair and asphalt repair. These shall be considered subsidiary to the pipeline installation and reimbursement for these items shall be included in the price bid for furnishing and installing the water line.

* Asphalt repair shall be paid under the item "Asphalt Repair".

- B. Unit of measure: LINEAR FOOT

1.3 GATE VALVES

A. PAYMENT

Payment will be made for costs associated with operations necessary to furnish and install gate valves as specified and shown on the Plans. Gate valves with valve boxes shall be measured and paid for at the unit price bid for each size valve, and incidentals furnished and installed.

- B. Unit of measure: EACH

1.4 FIRE HYDRANTS

A. PAYMENT

Payment will be made for costs associated with operations necessary to furnish and install fire hydrants as specified and shown on the Plans. Fire Hydrants shall be measured and paid for at the unit price contained in the bid proposal. Payment shall constitute full reimbursement for furnishing and installing a fire hydrant for 3 foot bury with megalug. Connecting pipe shall be paid as 6" pipe per the bid schedule. Gate valves shall be paid as gate valves per the bid schedule.

- B. Unit of measure: EACH

1.5 METAL DETECTABLE TAPE

A. PAYMENT

Payment will be made for costs associated with operations necessary to furnish and install metal detectable tape as specified and shown on the Plans. Measurement and payment for the metal detectable tape required, furnished and installed shall be made at the price per linear foot of "Metal Detectable Tape" as bid in the Proposal.

- B. Unit of measure: LINEAR FOOT

1.6 PAVEMENT REPAIR

A. PAYMENT

Payment will be made for costs associated with operations necessary to furnish and install asphalt repair as specified and shown on the Plans.

- B. Unit of measure: LINEAR FOOT

1.7 FIRE HYDRANT REFLECTORS

A. PAYMENT

Payment will be made for costs associated with operations necessary to furnish and install blue fire hydrant reflectors as specified and shown on the Plans.

B. Unit of measure: EACH

1.8 TAPPING SLEEVES AND TAPPING VALVES

A. PAYMENT

Payment will be made for costs associated with operations necessary to furnish and install tapping sleeves and tapping valves as specified and shown on the Plans. tapping sleeves and tapping valves shall be measured and paid for at the unit price bid for each size furnished and installed.

B. Unit of measure: EACH

PART 2 NOT USED

PART 3 NOT USED

-- END OF SECTION --

SECTION 01 04 01 - SUBMITTALS

PART 1 GENERAL

1.1 SUMMARY

The CONTRACTOR shall submit descriptive information to:

1. Allow the ENGINEER to advise the OWNER whether the materials and equipment proposed for the project are in general conformance with the design concepts and in conformance with the drawings and specifications.
2. Provide a record for the OWNER of the materials and equipment which have been incorporated into the project.
3. Provide a guide for operations and maintenance of equipment.
4. Provide information required for the administration of the Contract for construction of the project.
5. All submittals, shop drawing and other related documents include under this specification section shall be submitted electronically to the Engineer unless directed otherwise by the Engineer. The only exception being the Operation and Maintenance Manuals, which shall be submitted as directed under that item.

1.2 REFERENCE STANDARDS

PART 2 PROCEDURES

2.1 CONTRACTOR'S RESPONSIBILITIES

2.2 MARKING OF SUBMITTALS

- A. The CONTRACTOR shall assign a number to each submittal provided to the ENGINEER to allow each submittal to be tracked while processing through the review procedures.
- B. Assignment of numbers shall be by means of a letter prefix, a sequence number, and letter suffix to indicate resubmittal's.
- C. The sequence number shall be issued in chronological order for each submittal in a division. Resubmittal's shall be followed by a letter of the alphabet to indicate the number of times a submittal has been sent to the ENGINEER for processing, As an example, a submittal with the number SD-03-01 indicates that the submittal is the first in Division 3 submitted. Submittal number SD-11-04-AA indicates the submittal is the fourth shop drawing submitted in Division 11 and is being submitted for the second time. Operation and maintenance manuals submitted shall be identified with the same number as its corresponding equipment submittal. For example, OM-11-04 indicates that this is the operation and maintenance manual for the equipment submitted as SD-11-04.
- D. Correct assignment of numbers is essential as different submittal types are processed in different ways. Some submittals received do not require that any response be given for the material. CONTRACTOR and ENGINEER shall both maintain a log of submissions to allow the processing of CONTRACTOR's submittals to be monitored. Logs will be reviewed periodically to determine that all submittals are received and processed.
- E. Submittals shall be marked to show clearly the applicable sections of the specification and sheet number of drawings.
- F. Submittals shall be accompanied by a Submittal Transmittal Form to be provided by the CONTRACTOR. A separate form shall be used for each specific item, class of material, equipment, and items specified in separate discrete sections, etc. for which a submittal is required. Submittals for various items shall be made with a single form when the items taken together constitute a manufacturer's package or are so functionally related that they should be checked as a unit.

2.3 CONTRACTOR MODIFICATION REQUEST/PROPOSED CONTRACT MODIFICATION

- A. Any change in the contract documents that is requested will be initiated by the CONTRACTOR issuing a Contractor's Modification Request or by ENGINEER issuing a Proposed Contract Modification. Proposals will be considered and if found acceptable will be incorporated in a Field

Order in accordance with the General Conditions or Change Order in accordance with the General Conditions.

2.4 SHOP DRAWINGS

A. DEFINITION

1. As defined in the General Conditions, shop drawings consist of all drawings, diagrams, illustrations, schedules and other data which are specifically prepared by or for the CONTRACTOR to illustrate some portion of the work and all illustrations, brochures, standard schedules, performance charts, instructions, diagrams, and other information prepared by a supplier and submitted by CONTRACTOR to illustrate material or equipment for some portion of the Work.
2. Shop drawings shall indicate the kind, exact model, size, arrangement, and operation of component materials and devices; materials of construction, external connections, anchorages and supports required; performance characteristics; dimensions, weights, and other information required for installation and correlation with other materials and equipment.

B. SCHEDULE OF SUBMITTAL OF SHOP DRAWINGS

1. The CONTRACTOR shall submit, in accordance with the General Conditions, a schedule indicating the time and sequence in which Shop Drawings are to be submitted. This schedule shall consider the dates for incorporation of the materials or equipment into the project and take into consideration time for delivery and a reasonable time for review of shop drawings. Proposed order and delivery dates shall be incorporated in the Progress Schedule.
2. Shop drawings will generally be reviewed in the order in which they are received. Drawings marked "Priority" will be reviewed ahead of other shop drawing submittals not so marked which have already been received but are not yet being reviewed. CONTRACTOR shall be aware that checking of "Priority" shop drawings may delay the review of other drawings which have already been submitted by the CONTRACTOR and the use of this designation is to be used with discretion.

C. CONTRACTOR'S REVIEW AND CERTIFICATION

The CONTRACTOR shall verify that the material and equipment in each shop drawing conforms to the requirements of the Contract Documents. Shop drawings shall be in strict compliance with the Contract Documents and shall bear an executed statement to that effect by the CONTRACTOR. Shop Drawings without this stamp applied will be returned without review.

D. DEVIATIONS FROM CONTRACT DOCUMENTS

Requests for deviation from the Contract Documents shall be by Contractor's Modification Request as outlined in Paragraph 2.03 of this section of the specifications. The CONTRACTOR'S Modification Request shall fully identify and describe the deviations and state the reason the change is requested. Any savings in cost related to the substitution is to be stated in the request for consideration.

E. REQUIREMENT FOR COMPLETE SHOP DRAWINGS

1. Material in shop drawings shall be in sufficient detail to demonstrate compliance with all requirements of the Contract Documents. Shop drawings shall address material and/or methods of construction, design criteria, performance characteristics, and special provisions of the Specifications.
2. Shop drawings for systems and related equipment shall include information for all components required for a complete and operational system, including electrical, mechanical, and any other information required to indicate how the various components of the system function, and shall be included in the same submittal.
3. Where statements of certification, written guarantees, extended service agreements or extended warranties as defined in Paragraph J are required, they will be provided with the shop drawing. The effective date of the guarantee and service agreements, however, shall not be until the date of acceptance for the project.
4. Shop drawings shall be clearly marked to show the applicable sections of the specifications and sheet in the drawings. Other identification may also be required on

drawings such as layout drawings or schedules to allow the reviewer to determine where a particular item is to be used in the project.

5. One (1) electronic copy of each shop drawing shall be submitted to the ENGINEER and OWNER.
6. Shop drawings which do not have all of the information required for evaluation will be returned without benefit of review and comment.

F. CHECKING AND REVIEW OF SHOP DRAWINGS

1. The ENGINEER will review the data for general conformity to the Contract Documents. Comments will be made on items called to the attention of the ENGINEER for review and verification. Markings will be based on this examination and do not constitute a blanket review of the shop drawing. The ENGINEER's review does not relieve the CONTRACTOR from any responsibility for errors or deviations from the Contract requirements. Shop drawings which contain substantial error or omissions, or which are not clearly legible, will be returned without benefit of review.
2. Shop drawings will be marked in one of the three following ways:
 - a. Approved: Shop drawings are acceptable without correction and may be distributed for construction and/or manufacture.
 - b. Approved as Noted: Shop drawings are acceptable with minor corrections as marked and may be used with the corrections noted.
 - c. Rejected: Material or equipment described is not acceptable.

G. APPROVAL OF EQUAL SUBSTITUTIONS

Where Contract Documents allow substitution of material or equipment as an approved equal to the specified product, shop drawings shall be provided. Shop drawings shall include supporting data to indicate specifically, on a point-by-point basis for each feature of the design, how the proposed product is equal to or better than the specified product. Deviations from the Contract Documents must be requested and approved as described in Paragraph D.

H. SHOP DRAWINGS REQUIRED

Shop drawings are required for only those items of equipment or materials where submittals are listed in the individual specification section and for the determination of substitutions for approval as described in Paragraph G of this section. Only these shop drawings will be reviewed. Shop drawings which are not required may be returned with the notation "NOT REQUIRED BY THIS CONTRACT."

I. OWNER SELECTED OPTIONS

Where selections are to be made by the OWNER for color, texture or finish and shop drawings are required for that product, shop drawings will be submitted for approval of the materials of construction, composition, etc., prior to the selection of finishes by the OWNER. Items requiring selection of finish for which shop drawings are not required shall be furnished as record data. Selection of finish for materials shall be determined as described in Paragraph 2.13.

J. CERTIFICATIONS, WARRANTIES AND OTHER REQUIREMENTS

Where indicated in the Contract Documents the following items as defined below are to be provided as part of the shop drawing:

1. Certified Test Report - A report prepared by an approved testing agency on the results of tests performed on materials to indicate their compliance with the specifications. Reports are to be numbered consecutively for reference. Retest required to verify compliance with Contract Documents shall be identified with the same number as the original test with a letter to indicate retest, similar to the numbering system used for Shop Drawings.
2. Certification of Local Field Service - A certified letter stating that field service is available from a factory or supplier approved service organization located within a 300-mile radius of the project site.
3. Extended Warranty - A guarantee of performance for the product or system beyond the one-year warranty described in the General Conditions. The Warranty Certificate is to be issued in the name of the OWNER.
4. Extended Service Agreement - A contract to provide operations and maintenance for equipment as specified beyond that required to fulfill requirements for warranty repairs; or

to perform routine maintenance at some period beyond the warranty period. The Service Agreement is to be issued in the name of the OWNER.

5. Certification of Adequacy of Design - A certified letter from the manufacturer of the equipment stating that they have designed the equipment offered to account for structural stability to withstand all imposed loads without deformation, failure or adversely affecting the operational requirements of the unit; and operational capability, including mechanical and electrical equipment sizing to be fully operational in accordance with the conditions specified.
6. Certification of Applicator/Subcontractor Qualifications - A certified letter stating that the applicator/subcontractor proposed to perform a specified item of work is duly designated as factory-authorized and trained for the application or installation of the specified product.

2.5 RECORD DATA

- A. Record data shall be submitted to provide information as to the general character, style and manufacturer of the equipment to allow the OWNER to adequately identify the materials or equipment incorporated into the project. Record data shall be provided for all equipment and materials of construction. Record data are not required for items for which Shop Drawings and/or operations and maintenance manuals are required.
- B. Record data shall be complete to indicate where the material was incorporated into the project, provide schedules of materials and their use, colors, model numbers and other information which would allow this material to be replaced at some future date. Record data will be received by the ENGINEER and logged for transmittal to the OWNER. Record data will not be reviewed for comment and no response will be made to the CONTRACTOR.

2.6 PROJECT INFORMATION REQUEST

- A. When it is necessary for the CONTRACTOR to request additional information, interpretation of the Contract Documents, or when the CONTRACTOR believes there is a conflict between the drawings and specifications, he shall identify the conflict and request clarification using the Project Information Request form. Use of this form will allow requests for information to be routed to OWNER, design engineers, design consultants or others through the ENGINEER and allow these requests to be monitored to determine that clarification is provided when needed. Sufficient information shall be attached to permit a written response without further information.
- B. The ENGINEER will log each request and will review the request to determine that the information provided is adequate. If information is not adequate, the request will be returned for additional information. When adequate information is provided, the request will be reviewed and a response made. If a change is required, the ENGINEER will initiate a Proposed Contract Modification. If no change is required, the ENGINEER will provide additional information required to help the CONTRACTOR comply with the Contract Documents.

2.7 SCHEDULE OF VALUES AND PAYMENT ESTIMATES

- A. For contracts based on lump sum amounts, the CONTRACTOR is to submit to the ENGINEER for approval, a breakdown of cost for the Project. The breakdown is to provide adequate detail to allow easy determination of the percentage of completion for periodic payment review by the ENGINEER. Specification sections and add or deduct items in the proposal are to be used as a guide for preparing the breakdown. This breakdown is to be incorporated onto a form for the submission of payment request provided by the ENGINEER or in a form approved by the ENGINEER.
- B. The CONTRACTOR is to submit a schedule showing the anticipated schedule of payments for the CONTRACTOR to assist the OWNER in determining when funds are to be made available for payment of periodic payment requests.

2.8 PROGRESS SCHEDULES

- A. As required in the General Conditions, within 10 days prior to the submission of the first periodical estimate for partial payment, the CONTRACTOR shall prepare and submit to the ENGINEER an electronic copy of the schedule in which the CONTRACTOR proposes to carry on the work. The schedule is to include the date on which work will be started on each major activity, including procurement of materials and equipment, and the anticipated date for the

completion of each activity. The CONTRACTOR shall be responsible for developing the construction schedule and monitoring progress. The CONTRACTOR shall consider and include the schedules of all subcontractors, material and equipment suppliers to ensure that all necessary information is incorporated into the construction schedule.

1. Give early warning of delays in time for correction.
2. Require that detailed plans for the execution of the work be prepared in the form of future activities and events in sequential relationships.
3. Establish interrelationships of significant planned work activities and provide a logical sequence of interdependence of planned work activities.
4. Provide continuous current status information.
5. Allow analysis of the CONTRACTOR's program for the completion of the Project.
6. Permit preparation of new schedules when an existing schedule is not achievable.
7. Log the progress of the work as it actually occurs.

2.9 SUPPLIERS AND SUBCONTRACTORS

The Contractor is to provide a written list of subcontractors and suppliers prior to the preconstruction conference described in the General Conditions.

2.10 NOTIFICATION BY CONTRACTOR

Written notification of the need for testing, observation work by ENGINEER, intent to work outside of regular working hours, or the request to shut down the facilities or make utility connections shall be given to the ENGINEER by issuance of a Notification By Contract or on a form provided by the ENGINEER.

PART 3 NOT USED

-- END OF SECTION --

SECTION 01 09 01 - DISINFECTION OF POTABLE WATER PIPING AND TANKS

PART 1 GENERAL

1.1 REFERENCE STANDARDS

AWWA C651 - Disinfecting Water Mains; 2014.

AWWA C652 - Disinfection of Water-Storage Facilities; 2011.

AWWA C653 - Disinfection of Water Treatment Plants; Current Edition.

1.2 WORK INCLUDED

- A. Disinfection of water piping for filtered, finished, and potable water.
- B. Test and report results.

1.3 QUALITY ASSURANCE

- A. Testing Laboratory: State Health Department certified approved for examination of drinking water in compliance with applicable legislation of the State of Texas.
- B. Piping, tanks, and equipment to be cleaned and disinfected shall be isolated from the finished water (potable water) at all times and shall be placed into service by the OWNER following receipt of acceptable test reports.

1.4 REGULATORY REQUIREMENTS

Conform to applicable Texas Department of Health Rules and TCEQ Regulations for Public Water Systems for work of this section.

1.5 SUBMITTALS

- A. Submit a schedule of the proposed sequence for cleaning and method of sterilization to be used or list of the equipment to be used, and the sterilizing agent and quantities to be used, location and/or sizes of fill, blowdown connections, sources of test water, and proposed plan to dispose of test water.
- B. Submit electronic copies.
- C. Submit reports under provisions of Section 01 04 01.
- D. Disinfection report should accurately record:
 - 1. Type and form of disinfection used.
 - 2. Date and time of disinfectant injection start and time of completion.
 - 3. Test locations.
 - 4. Initial and 24-hour disinfectant residuals (quantity in treated water) in ppm for each outlet tested.
 - 5. Date and time of flushing in ppm for each outlet tested.
- E. Bacteriological report should accurately record:
 - 1. Data issued, project name, and testing laboratory name, address, and telephone number.
 - 2. Time and date of water sample collection.
 - 3. Name of person collecting samples.
 - 4. Test locations.
 - 5. Initial and 24-hour disinfectant residuals in ppm for each outlet tested.
 - 6. Coliform bacteria test results for each outlet tested.
 - 7. Certification that water conforms, or fails to conform, to bacterial standards of Texas Department of Health.
 - 8. Bacteriologist's signature.

PART 2 PRODUCTS

2.1 PRODUCTS - GENERAL

- A. Furnish necessary temporary connections, taps, valves, piping, pumps, hoses, chemicals, and test equipment to accomplish the work.
- B. Disinfection agents shall be chlorine solution prepared from chlorine gas, sodium hypochlorite, or calcium hypochlorite.

PART 3 EXECUTION

3.1 GENERAL

- A. CONTRACTOR shall exercise care at all times during construction to prevent contaminated material from entering the structures and pipelines in the filtered, finished, and potable water system.
- B. All facilities and piping designed to hold or transport process water shall be cleaned, including piping, basins, and channels, prior to disinfection.
- C. Filters, finished water storage tanks, pump station wet wells, pump cans, finished water piping, together with valves and meters, all potable water, service water, and chemical piping shall be disinfected with chlorine solution as specified herein following cleaning and testing. Vertical pumps may be disinfected immediately prior to installation. All surfaces shall be cleaned or washed and disinfected, even though there is no visible evidence of necessity thereof.
- D. Disinfection shall be in accordance with the disinfection procedure described in AWWA C651, AWWA C652, and AWWA C653, and in accordance with the Rules and Regulations for Public Water Systems of the Texas Commission on Environmental Quality and the requirements of this section. Where conflicts exist, the ENGINEER shall determine the appropriate procedures.

3.2 PIPELINE DISINFECTION

- A. Verify that piping system has been cleaned, inspected, and pressure tested. Flush out line, completely replacing its entire volume with potable water.
- B. Purging may be accomplished by passing an appropriate sized "polly-pig(s)" through the pipe, or by flushing.
 - 1. Polly-Pig Method
 - a. In-general, this shall consist of furnishing all equipment, material, and labor to satisfactorily expose cleaning wye, remove cleaning wye covers, etc., as directed by the OWNER's representative or resident inspector.
 - b. Where expulsion of the "polly-pig" is required through a dead-ended main, the CONTRACTOR shall make every effort to prevent backflow of purged water into the main after passage of the pig. One small pipe, such as cast iron pipe through 12 inches (30 cm), backwater re-entry into the pipe can be prevented by the temporary installation of mechanical joint shallow bends and pipe joints to provide a riser out of the trench. On larger pipe, additional excavation of the trench may serve the same purpose.
 - c. Short dead-end pipe sections not swabbed by the pig shall be flushed.
 - d. Backflow water which has inadvertently entered the pipe under conditions similar to those described in the preceding Paragraph b, shall be flushed from the system.
 - e. After passage of the "polly-pig," flushing of all backwater from the pipe, satisfactory test results are received, at the direction of the OWNER, the CONTRACTOR shall proceed with sterilization.
 - 2. Flushing Method: If the "flushing" method of purging is used, the CONTRACTOR shall be required to prepare the main by installing blow-offs at locations and sized as directed by the ENGINEER.
 - a. In general, this shall consist of furnishing all equipment, material and labor to satisfactorily install blow-offs of sizes shown in the following table:

SIZE MAIN	SIZE BLOW-OFF
2-8 Inches	2 Inch
10-12 Inches	4 Inch
16-24 Inches	6 Inch
30 Inches and greater	10 Inch

- b. Before disinfection, flush all foreign matter from the pipeline. Provide hoses, temporary pipes, ditches, etc., as required to dispose of flushing water without damage to adjacent properties. Flushing velocities shall be at least 2.5 fps. For large

diameter pipe where it is impractical or impossible to flush the pipe at 2.5 fps velocity, clean the pipeline in-place from the inside by brushing and sweeping, then flush the line at a lower velocity.

- c. After flushing is complete and satisfactory test results are received at the direction of the OWNER's representative or resident inspector, the CONTRACTOR shall proceed with sterilization.
- C. Perform scheduling and disinfection activity with startup, testing, adjusting, and balancing, and demonstration procedures, including coordination with related systems.
- D. Provide and attach equipment required to execute work of this section. Do not place concentrated quantities of commercial disinfectants in the line before it is filled with water. Inject treatment disinfectant into piping system being sterilized so that its entire capacity will be filled with potable water containing a free chlorine residual at a level of 50 ppm or other quantity as determined by the ENGINEER. The disinfectant shall be added at one end of the sections being treated through a corporation stop or other approved connection inserted in the horizontal axis of the newly laid pipe. The water being used to fill the line shall be controlled to flow into the section to be sterilized very slowly, and the rate of application of the chlorinating agent shall be in such proportion of the rate of water entering the line that the chlorine dose applied to the water entering the line and released at the opposite end shall have a chlorine concentration of 50 ppm or a level determined by the ENGINEER. Valves shall be manipulated so that the strong chlorine solution in the line being treated will not flow back into the line supplying the water. If required by the OWNER and ENGINEER the CONTRACTOR shall use RPZ device to prevent water from flowing back into the supply line. All valves shall then be closed and the chlorine solution shall remain in the line for a minimum of 24 hours. A minimum residual of 10 ppm shall be present in the main following the 24-hour holding period. Operate all valves, hydrants, and other appurtenances during disinfection to assure that the disinfecting mixture is dispersed into all parts of the line, including dead ends, and similar areas that otherwise may not receive the disinfecting solution.
- E. Remove the chlorine solution and flush the line with potable water. Comply with regulations and obtain necessary approvals for disposal or discharge of chlorine solution and flushing water.
- F. The OWNER will take samples from the sterilized line through a suitable point in accordance with AWWA C651 (not a fire hydrant) and submit to the testing laboratory. A minimum of one sample shall be taken for each 1000 feet of line tested. A second set of samples shall be taken and submitted to the testing laboratory 2 days after the first samples were taken. The sterilized portion of the line shall be placed in service, if the results of two consecutive tests conform to the bacterial standards. If the samples show unsatisfactory quality, the sterilization process shall be repeated until satisfactory results are obtained.

3.3 DISPOSAL OF DISINFECTION WATER

The disinfecting water shall be dechlorinated before being released to natural drainage ways. See AWWA C652 for acceptable neutralization methods. Release neutralized disinfecting water at a controlled rate which shall not damage downstream facilities.

-- END OF SECTION --

SECTION 03 09 01 - GENERAL CONCRETE

PART 1 GENERAL

1.1 REFERENCE STANDARDS

- AASHTO M85 - Standard Specification for Portland Cement; Current Edition.
- ASTM A1064/A1064M - Standard Specification for Carbon-Steel Wire and Welded Wire Reinforcement, Plain and Deformed, for Concrete; 2015.
- ASTM C33/C33M - Standard Specification for Concrete Aggregates; 2016.
- ASTM D1751 - Standard Specification for Preformed Expansion Joint Filler for Concrete Paving and Structural Construction (Nonextruding and Resilient Bituminous Types); 2004 (Reapproved 2013).
- TxDot Item 423, (2004) Hydraulic Cement Concrete
- THD Bulletin C-11, Construction Bulletin Procedures for the Design and Control of Portland Cement Concrete Mixtures

1.2 WORK INCLUDED

Concrete shall consist of Portland cement, aggregates, and water which shall conform to the requirements as hereinafter specified. All concrete placed under this contract shall be in conformity with this specification.

1.3 SUBMITTALS

- A. Submit complete information for each concrete mix proposed. Include location for mix and proposed finishes.

PART 2 PRODUCTS

2.1 MATERIALS

- A. Cement shall be a standard brand of Portland cement, Type I, in conformity with AASHTO M85. Only one brand of cement may be used in any one structure.
- B. Coarse Aggregate shall comply fully with the minimum requirements of ASTM C33/C33M, for 1 ½ inch maximum size aggregate.
- C. Fine Aggregate shall comply fully with the minimum requirements of ASTM C33/C33M.
- D. Reinforcing Steel shall be new deformed reinforcing bars, ASTM A1064/A1064M, of sizes and shapes noted on the Plans.
- E. Premolded Expansion Joint Material shall conform with the requirements of ASTM D1751.

2.2 CLASSIFICATIONS & PROPORTIONS

- A. Concrete shall be proportioned using methods outlined in the THD Bulletin C-11 for design of a concrete batch to meet the requirements hereinafter set forth. It shall be the entire responsibility of the CONTRACTOR to procure the strength as set out below for the respective class of concrete. All concrete shall be Class C unless otherwise shown on Plans. The concrete shall be uniform and workable. The minimum cement content, maximum allowable water content, and maximum slump shall conform to the following:

Class of Concrete	Minimum Cement (Bags / Cu. Yd.)	Maximum Water (Net Gal / Bag)	Maximum Slump for Hand Tamping	Maximum Slump for Machine Vibration
A	5.00	7.0	4"	3-1/2"
B	4.50	7.5	4"	3-1/2"
C	5.25	6.5	4"	3-1/2"

- B. The concrete mix will be designed with the intent of producing concrete which, when cured and tested as outlined in THD Bulletin C-11, will have strength equal to or greater than the following:

Class of Concrete	Compressive Strength (1lb per Sq. In.)	7-Day Flexural Strength (1 lbs psi)
-------------------	---	---

	28 - Day	7 - Day	
A	3,000	2,250	500
B	2,500	1,875	470
C	3,500	2,600	650

- C. If the strength required for the concrete being produced is not secured with the minimum cement content specified, additional cement shall be used or other aggregates provided at the CONTRACTOR's expense.
- D. Air entrainment shall be used for all exterior concrete.

2.3 CONSTRUCTION JOINTS

Construction joints shall be made only where located on the Plans, unless otherwise approved by the ENGINEER.

2.4 FORMS

All forms shall be of wood or metal and shall be built mortar tight and of sufficient rigidity to prevent distortion due to the pressure of the concrete and other loads incident to the construction operations. Forms shall be constructed and maintained to prevent warping and opening of joints due to shrinkage of the lumber.

2.5 STEEL REINFORCEMENT

- A. Reinforcing steel in the sizes, shapes and lengths as shown shall be placed in the positions as indicated on the Plans. Minimum cover of not less than 1" of concrete shall be provided over the surface of all reinforcing steel.
- B. Stirrups and hoops shall pass around the main reinforcement members and shall be securely attached thereto. The reinforcing steel shall be spaced and secured in the forms by means of approved galvanized metal spacers or precast motor blocks. Steel shall be wired together at all intersections; and when completed, the reinforcement mat shall present practically a rigid cage of steel which will not be distorted or shifted from position in any way by workmen walking on the mat or by concrete placement operations. Reinforcing steel in horizontal slabs shall be supported by chairs to ensure accurate placement. Do not lift reinforcement during concrete placement.
- C. Splicing of bars will be permitted only where shown on the Plans or with the specific approval of the ENGINEER. The bar splice, when so made, shall not be less than 36 bar diameters with the spliced bars securely tied.
- D. Steel bars, when placed in the work, shall be completely free of dirt, grease, loose rust, scale or other foreign matter. After placement, care shall be exercised to keep the steel free of mud, dried concrete or other material. No concrete whatsoever shall be deposited in the forms until the ENGINEER has inspected the final placement and condition of the reinforcement and approved the work for placement of concrete.

PART 3 EXECUTION

3.1 MIXING CONCRETE

- A. Mixing at Site: Concrete shall be thoroughly mixed in a batch mixer of an approved size and type which will insure a uniform distribution of the materials throughout the mass, equipped with adequate water storage and a device for accurately measuring and automatically controlling the amount of water used in each batch.
- B. Truck Mixing: Truck mixers shall be of the revolving drum type, water tight, and so constructed that the concrete can be mixed to insure uniform distribution of materials throughout the mass.
- C. Time of Hauling and Placing Mixed Concrete: Concrete transported in a truck mixer shall be placed in its final position in the forms within 1 ½ hours after the introduction of the mixing water to the cement and aggregate.
- D. Delivery Rate of Concrete during concrete operations shall be such as to provide for the proper handling, placing and finishing of the concrete, and the interval between batches shall not exceed 20 minutes. Concrete which has partially hardened shall not be retempered or remixed.

3.2 HANDLING AND PLACING OF CONCRETE

- A. During and immediately after depositing, concrete shall be thoroughly compacted by mechanical vibration with satisfactory equipment and in a manner and to the extent as may be approved by the ENGINEER. Concrete shall not be poured in weather below freezing.
- B. In preparation for placement of concrete, all sawdust, chips or other construction debris and extraneous matter shall be completely removed from the interior of the forms. When placing concrete on previously placed construction joints, the surface shall be cleaned by compressed air or vacuum methods, if so directed, and the surface of the existing joint shall be completely free of dust, dirt, sawdust or other foreign material. Concrete shall not be placed in any form prior to specific inspection and approval by the ENGINEER.
- C. Foundations and footings shall be placed on firm, undisturbed earthen subgrade which is free of mud or excessive moisture. If groundwater is encountered, prior to placement of concrete the area shall be dewatered sufficiently for the subgrade to be firm and stable with the last 6 inches of excavation being removed immediately ahead of the concrete placement. Concrete for footing and/or foundations will not be placed on unstable, soggy or otherwise unsatisfactory earthen subgrade.
- D. Concrete shall be placed in a manner to avoid segregation of the materials and the displacement of reinforcement. All chutes, troughs, tremies and pipes shall be kept clean and free from coatings of hardened concrete. When placing operations involving dropping the concrete more than 5 feet, the concrete shall be deposited through approved pipes or tremies. In walls less than 11 feet in height and widths less than 12 inches, tremies will not be required.
- E. During and immediately after depositing, the concrete shall be thoroughly compacted by mechanical vibrating equipment and in a manner and to the extent as may be approved by the ENGINEER. Where placed in sidewalks, pavement or driveways, satisfactory hand methods for compaction and consolidation may be used.
- F. Concrete shall be placed in horizontal layers not more than 12" thick except as provided herein. When less than a complete layer is placed in one operation, it shall be terminated in a vertical bulk head. Each layer shall be placed and compacted before the preceding batch has taken initial set to avoid surfaces of separation between the batches and to avoid the formation of construction joint with a preceding layer and surfaces of separation between batches.
- G. When placement of concrete is unavoidably temporarily discontinued, the concrete, after becoming firm enough to retain its form, shall be cleaned of laitance and other objectionable material to a sufficient depth to expose sound concrete, and the top surface of the concrete adjacent to the forms shall be smoothed with a trowel. Where a "feather" edge might be produced at a construction joint, an inset formwork shall be used to produce an edge thickness of not less than 6" in the succeeding layer. Work shall not be discontinued within 18" of the top of any face, unless provisions have been made for a coping less than 18" thick, in which case, and if permitted by the ENGINEER, the construction joint may be made at the underside of the coping.
- H. CYLINDER OR BEAM TESTS: During work progress, the OWNER, at his discretion, shall have cylinders or beam tests performed as specified herein. The laboratory testing and services shall be provided by the OWNER. The OWNER does hereby reserve the right to collect all cylinder samples himself, if desired, and deliver same to the testing laboratory approved to perform the tests prior to the placement of concrete. The tests will be performed to maintain a check on the compressive or flexural strength of the concrete that is actually placed. The test shall be defined as the average of the breaking of two cylinders or two beams as the case may be. Test beam or cylinder specimens shall be required for each 167.5 cubic yards, or a portion thereof, placed each day. For smaller concrete placements, the OWNER's Representative may vary the test specimen to 25 cubic yard placement, over a several day period. Cylinders or beam specimens shall be field protected per THD Bulletin C-11 until transported to the testing laboratory. The test specimens shall be cured in accordance with THD Bulletin C-11

3.3 CURING & FINISHING

- A. Concrete surfaces exposed to conditions causing premature drying shall be protected by covering as soon as possible with approved curing compound, burlap, sand, or other

satisfactory material and kept moist. Curing shall continue for a period of not less than 7 days after placing the concrete.

B. Surface finishes shall be classified as follows:

1. Class I - Ordinary Surface Finish
2. Class II- Rubbed Finish
3. Class III - Broom Finish
4. Class IV - Steel Trowel Surface Finish
5. Class V - Adhesive Grout Finish
6. Class VI - Sidewalk Finish

All concrete shall be given Class I, ordinary surface finish, and in addition, if further finishing is required, such other types of finish as specified. If not otherwise specified, the following surfaces shall be given Class II -Rubbed Finish: exposed faces of structures; outside faces of slabs, brackets, curbs, headwalls, railings. Slab surfaces shall be given Class III - Broom Finish and Class IV - Steel Trowel Surface Finish.

C. Inspector to approve all finishes for slabs prior to their installations. Contractor to acquire from Engineer written instruction of finishing slabs in each specific area of building and exterior slabs.

1. Class I, Ordinary Surface Finish: Immediately following the removal of forms, all fins and irregular projections shall be removed from all surfaces except from those which are not to be exposed. On ALL surfaces, the cavities produced by form ties and other holes, honey comb spots, broken corners or edges and other defects shall be thoroughly cleaned, carefully pointed and cured with a mortar of cement and fine aggregate. The resulting surface shall be to the satisfaction of the ENGINEER.
2. Class II, Rubbed Finish: After removal of forms, the rubbing of concrete shall be started as soon as its condition will permit. Immediately before starting this work, the concrete shall be kept thoroughly saturated with water for a minimum period of three hours. Surfaces to be finished shall be rubbed with a medium carborundum stone, using a small amount of mortar on its face. The mortar shall be composed of cement and fine sand mixed in proportions used in the concrete being finished. Rubbing shall be continued until all form marks, projections and irregularities have been removed, all voids filled, and a uniform surface has been obtained. The final finish shall be obtained by rubbing with a fine carborundum stone and water. This rubbing shall be continued until the entire surface is of a smooth texture and uniform color.
3. Class III, Broom Finish: After the concrete is compacted, the surface shall be carefully rodded and struck off with a strike board to conform to the cross-section and grade shown on the Plans. After striking off and consolidating as specified above, the surfaces shall be made uniform by longitudinal or transverse floating, or both. When the concrete has hardened sufficiently, the surface shall be given a broom finish with a broom of an approved type. The strokes shall be square across the slab, from edge to edge with adjacent strokes slightly overlapped. The surface when finished shall be uniform, free of porous spots, irregularities, depressions and small pockets or rough spots.
4. Class IV, Steel Trowel Finish: The concrete surface shall be struck off and given a float finish as outlined for Class III finish above. After the surface has been tested with a straight edge and irregularities corrected, the entire system shall be finished with an acceptable steel bladed rotary type mechanical finishing machine to a smooth and uniformly finished condition. Hand troweling methods with a steel trowel will be used to finish corners or other areas inaccessible to the finishing machine and to remove all blade marks, burrs and other irregularities left by the machine, and the entire surface completed in a smooth and workmanlike manner, of uniform texture, and to the entire satisfaction of the ENGINEER.
5. Class 5, Adhesive Grout Finish: The surface of the concrete shall be given an Class 1 finish, chamfer lines lightly rubbed, irregularities corrected, and then covered with an adhesive grout textured coating a minimum of 1/16" thickness. Coating shall be composed of one part white cement, one part natural (gray) cement, two parts masonry and, one part (latex) emulsion and enough water to form a viscous slurry of a consistency that may be applied by spray gun, brush or roller with appreciable running or sagging. The

proportions of white and gray cement may be varied slightly to obtain the desired color. Gradation of the masonry sand shall be as required to product a texture satisfactory to the ENGINEER. Prepackaged materials meeting these requirements and acceptable to the ENGINEER as to color, texture and appearance will be permitted. The adhesive grout coating shall be applied to the moistened concrete surface in a manner which will provide a uniform texture and color, in the thickness specified, and shall be completely protected from rain and/or freezing for a period of 24 hours minimum.

The adhesive grout type coating shall meet the test requirements of TxDot Item 423 for Adhesive Grout Type Coatings. If requested, the CONTRACTOR shall furnish the ENGINEER a certificate from the manufacturer stating the product furnished complies with these specifications.

6. Class 6, sidewalk Finish: After the concrete has been deposited in place, it shall be compacted, the surface struck off by means of a strike board, and then finished with a steel trowel. An edging tool shall be used on all edges and at all expansion joints and dummy joints. The surface shall not vary more than 1/8" under a 10 foot straight edge. The surface shall then be given a granular or matted texture by light brushing with a wetted brush or broom to provide a non-skid surface when wet and meeting the entire approval of the ENGINEER.
- D. Temperature of Concrete: When placing concrete at a temperature below 45 degrees F., the concrete shall have a temperature not lower than 50 degrees F. and not higher than 90 degrees F. Suitable means shall be provided to maintain the concrete at a temperature not less than 50 degrees F. for the first five days after placement, or until it has hardened sufficiently, or until the first three days if high early strength concrete is used. The method of heating the materials at all times shall be subject to the ENGINEER's approval. No salt, chemical or other foreign matter shall be mixed with the concrete for the purpose of preventing freezing. If warm water is used, the cement shall be put in before other aggregates to prevent a flash set. If concrete is placed when weather is such that the temperature of the concrete would exceed 90 degrees F., as determined by the ENGINEER, the CONTRACTOR shall employ effective means, such as placing early in the day, as necessary to maintain the temperature of the concrete as it is placed below 90 degrees F.

-- END OF SECTION --

SECTION 31 01 01 - FLOWABLE FILL

PART 1 GENERAL

1.1 REFERENCE STANDARDS

- ACI 229R - Report on Controlled Low-Strength Materials; Latest Edition.
- ASTM C109/C109M - Standard Test Method for Compressive Strength of Hydraulic Cement Mortars (Using 2-in. or (50-mm) Cube Specimens); 2016a.
- ASTM C138/C138M - Standard Test Method for Density (Unit Weight), Yield, and Air Content (Gravimetric) of Concrete; 2016a.
- ASTM C150/C150M - Standard Specification for Portland Cement; 2016.
- ASTM C33/C33M - Standard Specification for Concrete Aggregates; 2016.
- ASTM C494/C494M - Standard Specification for Chemical Admixtures for Concrete; 2016.
- ASTM C495/C495M - Standard Test Method for Compressive Strength of Lightweight Insulating Concrete; 2012.
- ASTM C94/C94M - Standard Specification for Ready-Mixed Concrete; 2016a.

1.2 WORK INCLUDED

- A. Scope: This Section governs flowable fill or controlled low strength material for pipe embedment, encasement, and backfill. Flowable fill shall be utilized for all encasement and pipe caps for yard piping.
- B. Flowable fill shall be described as a low cement content ready-mix material with high flow properties. Where flowable fill is shown for use on the Plans or described in the Specifications, it is intended that such fill be able to be removed at a later date if so desired with the use of ordinary trenching equipment or by hand excavation, High Air Generators shall be used with flowable fill to reduce shrinkage and/or facilitate pumping and/or limit compressive strength potential for future excavations.

1.3 RELATED SECTIONS

- A. Section 01 04 01 - CONTRACTOR's Submittals.
- B. Section 03 09 01 - General Concrete.
- C. DIVISION 2 - Sitework.

1.4 QUALITY ASSURANCE

Material suppliers shall demonstrate experience in the manufacture of ready-mix concrete and flowable fill. Mix design submittal shall include quality statement on flowable fill performance, documented strengths, and previous applications.

1.5 SUBMITTALS

- A. Submit mix designs with proportions of each component; strengths at 7 days and 28 days, materials descriptions with types and classifications, test results, density in-place and of wet mixture, air content, viscosity, setting time, shrinkage, yields, and flowability and pumpability characteristics. Mix design shall include batch proportions with unit weight measurements. Furnish information on methods and procedures proposed for grouting, and blocking and bulkhead designs and locations.
- B. Suppliers utilizing materials to reduce shrinkage and/or lower compressive strength potential shall submit manufacturer's data on properties in comparative mixtures.

PART 2 PRODUCTS

2.1 MANUFACTURERS

DaraFill Flowable Fill Performance Additive - Grace Construction Products or approved equivalent.

2.2 MATERIALS

- A. Cement - Type I - ASTM C150/C150M or blended cement with flyash meeting the requirements for use in concrete.
- B. Aggregate shall be free of organics and shall conform to ASTM C33/C33M.

- C. Admixtures: DaraFill as manufactured by Grace Construction Products, or approved equivalent. Material shall be added per manufacturer's recommendations to achieve strength, flowability and pumpability requirements.

2.3 CONCRETE MIXES

- A. CONTRACTOR shall develop mix designs of flowable fill for each application required and shall coordinate flowability, pumpability, unit weight, strength, and air content for each application. Air contents shall be between 15 percent and 30 percent. Minimum cementitious content shall be 200 pounds per cubic yard. Concrete mixtures shall provide high flow properties without segregation. Shrinkage shall be less than 1 percent by volume.
- B. Unless otherwise noted, flowable fill shall be designed for between 200 psi and 500 psi at 28 days. In absence of test data, provide mixtures with materials described above and having wet unit weight measurements in the range of 95 to 115 lbs/cu ft.
- C. Flowable fill may be completely mixed in a concrete truck or manufactured at the job site by mixing cement-sand slurry with a preformed foam.

PART 3 EXECUTION

3.1 GENERAL

- A. For annular space grouting, the entire annular space and length of the space shall be filled with grout, produced and placed by experienced personnel, using manufacturer's approved methods and equipment.
- B. General procedure shall be to bulkhead both ends of the annular space or piping or trench to be filled. In long closures, provide ventilation taps where necessary. Secure flumes and pipe to prevent floatation during placement of flowable fill. Secure members mechanically, or bed with short lift of stiff flowable fill.
- C. Fill for pipe encasement shall be done in lifts unless otherwise approved by the ENGINEER. CONTRACTOR shall coordinate fill locations and grouting pressures with flowable fill design such that specified grouting pressures are not exceeded. Removable internal stiffeners may be installed provided no internal modification or damage is done to the Pipe.
- D. The annular volume or pipe volume to be filled shall be calculated and utilized as a verification that the entire space has been filled. The consumed volume shall also be monitored and shall be acceptable if within 10 percent of the calculated volume.
- E. For all applications, the CONTRACTOR shall plan deliveries and/or production of flowable fill to ensure continuous grouting operation for the entire segment until completed.
- F. For grouting other than annular spaces and for use of flowable fill as trench backfill under paved areas, CONTRACTOR shall block and anchor pipe to grade and alignment to prevent floatation or movement during placement and flowable fill shall be placed in a minimum of 2 lifts, the first one below and to not more than D/4 on the sides of the pipe.

3.2 TESTING

For every flowable fill application, CONTRACTOR shall obtain three (3) samples of each batch and test compressive strength in accordance with ASTM C495/C495M or ASTM C109/C109M for 7-day and 28-day strengths.

-- END OF SECTION --

SECTION 31 03 01 - TRENCHING, BACKFILLING AND COMPACTING

PART 1 GENERAL

1.1 WORK INCLUDED

Trenching for buried piping systems as well as subsequent embedment, backfill and compaction operations, necessary to install the pipe as specified.

1.2 QUALITY ASSURANCE

1.3 REFERENCE STANDARDS

TxDOT Specification Item 247

TxDOT Specification 340

1.4 PROTECTION

- A. Protect trees, shrubs, and lawn areas to receive planting, and other features remaining as part of final landscaping.
- B. Protect benchmarks, existing structures, roads, sidewalks, paving and curbs against damage from vehicular or foot traffic. Install and maintain bridging, planking and cants to provide access to Work.
- C. Protect excavations by shoring, bracing, sheet piling, underpinning, or by other methods, as required to prevent cave-ins or loose soil from falling into excavations.
- D. Underpin or otherwise support adjacent structures which may be damaged by excavation work. This includes service lines and pipe chases.
- E. Notify the ENGINEER of unexpected subsurface conditions.
- F. Where damage could result from continuing work, discontinue work in area until resident inspector notifies the CONTRACTOR of the required modifications.
- G. Protect bottom of excavations and soil around and beneath foundations from frost, freezing, and excessive moisture changes.
- H. Grade around trenches to prevent surface water runoff into excavated areas.
- I. Protect above or below grade utilities including lateral lines, sprinkler system lines, and all other lines which are to remain. The cost of replacing damaged lines is to be borne by the CONTRACTOR.

PART 2 PRODUCTS

2.1 BED AND FILL MATERIALS

- A. Refer to specifications Section 31 06 01, SITE GRADING AND EARTHWORK, for requirements of Aggregate Fill Classifications and to the Drawings for locations and dimensional requirements.
 1. Embedment and initial backfill for PVC pipe larger than 2 inches, steel pipe, and DIP pipe shall be Class 2 Aggregate Fill. If not shown on the Plans, embedment and initial backfill shall be Class 2 Aggregate fill. Embedment and initial backfill for small plastic pipe shall be sand fill.
 2. Embedment for RCCP and HCP shall be Class 3 Aggregate Fill. Initial backfill shall be non-expansive earthfill.
 3. Flowable fill (foam grout) shall conform to specifications Section 31 01 01, FLOWABLE FILL.
 4. Concrete shall conform to Section 03 09 01, GEENERAL CONCRETE.
 5. Trench backfill under paving and to 5 feet outside of pavement shall be sand to within top 1 foot. Top 1 foot shall be Flowable fill with top 2 inches being cold mix asphalt.

PART 3 EXECUTION

3.1 PREPARATION AND LAYOUT

- A. Establish extent of excavation by line and elevation. Designate and identify datum elevations.
- B. Set required lines and levels.
- C. Maintain benchmarks, monuments and other reference points.

3.2 UTILITIES

- A. Known underground utilities are indicated on the Drawings.
- B. Before starting excavation, establish the location and extent of underground utilities occurring in the work area.
- C. As excavation approaches utilities, hand excavate to uncover utilities.
- D. Notify the ENGINEER for direction for removal and/or relocation of utility companies' lines which are in the way of excavation.
- E. Maintain, re-route or extend as required, existing utility lines to remain which pass through work area with the approval of the OWNER. Relocations are at the CONTRACTOR's cost.
- F. Protect utility services uncovered by excavation.
- G. Accurately locate and record abandoned and active lines rerouted or extended on Project Record Documents.

3.3 TRENCHING

- A. Ensure trenching does not interfere with normal 45 degree bearing splay of any foundation.
- B. Excavate in accordance with lines and grades. Excavated material which meets respective backfill requirements may be used for backfilling, stockpile or remove as applicable.
- C. Cut trenches sufficiently wide to enable proper installation of services and to allow for inspection. Minimum trench width shall be 6 inches wider than the pipe outside diameter. Pipe shall be installed in center of trench, with not more than 12-inch clearance nor less than 4-inch clearance between pipe wall and trench wall at any point. Trim and shape trench bottoms and leave free of irregularities, lumps and projections. Over excavated trench depths shall be filled to the proper grade with embedment material at no additional cost to the OWNER.
- D. Existing pavement over trenches shall be removed to a width of 6 inches outside the trench on each side by sawing methods and to a neat line. Asphalt pavements shall be sawed for full depth. Concrete pavement shall be sawed to a depth which will allow the section to be removed smoothly without underbreakage. Brick pavement shall be removed by hand methods in a manner that will not damage bricks, and the bricks shall be delivered and hand stacked as designated by the OWNER.
- E. Trench width shall be not more than 24 inches wider than outside diameter of pipes. Walls shall be vertical to elevation equal to 12 inches above the top of the pipe. Whenever the prescribed maximum trench width is exceeded, the CONTRACTOR shall use the next higher class of embedment, at no additional cost to the OWNER.
- F. Do not disturb soil within branch spread of existing trees or shrubs that are to remain. If it is necessary to excavate through roots, perform work by hand and cut roots with a sharp axe.
- G. When complete, request the resident inspector to inspect excavations. Correct unauthorized excavation as directed, at no cost to the OWNER.
- H. If, in the opinion of the resident inspector, the undisturbed material at grade depth is unstable, the CONTRACTOR shall be required to remove the unstable material and fill the trench to the proper subgrade with embedment material. Payment will be made to the CONTRACTOR at the unit price per cubic yard set forth in the Bid Schedule.
- I. Unsuitable excavated subsoil including perishable, spongy material, large rock, or other material designated by the resident inspector shall not be used in backfilling. Unsuitable material shall be disposed of by the CONTRACTOR in a manner approved by the resident inspector.

3.4 SHEETING AND SHORING

- A. In caving ground or in wet, saturated or flowing or otherwise unstable materials, the sides of all trenches and excavations shall be adequately sheeted and braced, to maintain the excavation from slides or cave-ins and to provide safety for workmen.
- B. Sheeting and shoring shall be designed by professional ENGINEER, licensed in the State of Texas.
- C. Sheeting, shoring, and bracing shall be removed unless otherwise approved by the ENGINEER. Removal of sheeting, shoring, and bracing shall be performed in a manner to prevent damage to new or existing structures and to avoid cave-ins or sliding of the banks. All holes and voids

from the sheeting shall be immediately and completely filled and compacted with suitable materials. All costs associated with the abandonment of sheeting, shoring and bracing shall be borne by the CONTRACTOR.

3.5 DEWATERING

- A. Keep trenches dry. Provide necessary equipment including pumps, piping and temporary drains. Maintain groundwater level a minimum of 3 feet below bottom of excavations during construction.
- B. Direct surface drainage away from excavated areas. Provisions shall be made for the satisfactory disposal of water pumped to prevent damage to public or private property.
- C. Control the grading in and adjacent to excavations to prevent water running into excavated areas or onto adjacent properties or thoroughfares.
- D. Furnish and operate suitable pumps on a 24 hour basis to keep excavations free of water until services have been placed and backfilling is completed.

3.6 BEDDING

The CONTRACTOR shall install the pipe and complete the bedding so that the installation may be inspected prior to backfilling. The OWNER's inspector shall be notified by the CONTRACTOR when the bedding is complete for each particular segment. Any excavation areas backfilled without the OWNER's prior inspection will require uncovering and checking at the CONTRACTOR's expense.

Manually place and compact bedding material in layers not exceeding six inches.

Manually shape bedding material to conform to pipe barrel and bell or flanges such that the entire length of the pipe barrel is supported by the bedding material.

Embedment and initial backfill materials shall be placed as shown on the plans and compacted in six inch layers along sides of pipe and to a minimum depth of 12 inches over the top of the pipe.

3.7 SETTING VALVES, VALVE BOXES AND FITTINGS

Gate valves and pipe fittings shall be set joint to new pipe in the manner specified for cleaning, laying and jointing pipe.

Valve boxes shall be firmly supported and centered plumb over the wrench nut of the gate valve, with box cover flush with the surface of the finished pavement or at such level as directed.

Standard plugs shall be inserted into the bells of all dead ends of pipe, tees or crosses and spigot ends shall be capped. Plugs or caps shall be jointed to the pipe or fitting in the manner specified above.

Concrete blocking will be required at all tees, bends, crosses and fire hydrants as provide herein. Blocking shall be placed between solid ground and the fittings. The bearing on the pipe and ground to be as detailed or as may be directed.

3.8 BACKFILLING

After pipe has been laid on the specified bedding material and all joints have been made, the backfilling of the trench shall begin. All trenches as a minimum shall have the bedding material extended to the top of the pipe and select backfill to a point 8" above top of pipe. Except as specified for backfilling trenches in streets, the remainder of the trench shall be backfilled using material excavated. In areas where the natural terrain provides less than 2 feet of cover for the proposed line, the CONTRACTOR shall construct a backfill mound over the trench. This trench shall be no less than 6 feet wide, not greater than 14 inches tall, and shall provide 24 inches of cover over the proposed line. In areas where the proposed line crosses drainage channels, a 6 inch concrete cap shall be placed over the line to the satisfaction of the ENGINEER.

- A. Do not start backfilling until services have been inspected.
- B. Ensure trenches are free of building debris, snow, ice, and water and that ground surfaces are not in a frozen condition.
- C. Backfill systematically and as early as possible to allow maximum time for natural settlement and compaction.

- D. Place and compact backfill materials in continuous layers according to the approved method of compaction. Use a method which will not disturb or damage services. No excessively large rocks or debris of any sort shall be used as backfill.
- E. Maintain moisture content and compaction density of fill materials as required.
- F. Acceptable backfill shall be placed from eight inches over the pipe to the surface.
- G. Excavated unsuitable material and excess material shall be disposed of by the CONTRACTOR in a manner approved by the resident inspector or OWNER's representative.
- H. Backfilling Trenches in Alleys and Outside Roadways: After pipe has been placed to the grade, alignment and bedding to 6" above the top of pipe, the trench shall be backfilled with select material. The select backfill shall be placed carefully by depositing the backfill material vertically by hand or by machines in such a manner that the pipe will not be displaced laterally and the pipe will not be damaged by contact with the backfill material, tools or equipment. Above this level, backfill may be shoveled or pushed into the ditch by hand or machine, completely filling the trench. In no event shall the backfill material contain rocks larger than 4 inches. Any excess excavated material shall be disposed of to the satisfaction of the OWNER. Any deficiency of backfill material shall be supplied by the CONTRACTOR.
- I. Backfilling Trenches under Pavement, Concrete, Gravel Streets, Highways: Where the trench crosses or lies within existing paved or graveled areas, the trench shall be backfilled with sand or granular material to top of finish grade for a distance of 8 feet outside the edge of paving and shall be jetted. The base material for the 12" crushed base course shall meet the requirements of TxDOT Specification Item 247, Grade 1, Type A. In paved areas the base course shall be primed with 0.25 gallon per square yard with MC-30. After allowing a minimum of 6 hours curing time, the areas shall receive 2 inches of Type "D" hot mix asphalt. Asphalt shall meet the minimum requirements of TxDOT Specification 340.

3.9 COMPACTION

- A. Compact embedment and initial backfill materials per the Construction Drawings.
- B. Remove and replace improperly compacted backfill material at no cost to OWNER. Additional trench settlement following completion shall be restored to a level surface. Trench surfaces may be left crowned in open country.
- C. Water jetting for consolidation will not be permitted within 25 feet of any structures, unless acceptable to the ENGINEER.

3.10 TRENCH SETTLEMENT

The CONTRACTOR shall be responsible for all settlement of backfills, fills, and embankments which may occur within one (1) year after final completion of the contract under which the work was performed.

The CONTRACTOR shall make, or cause to be made, all repairs or replacements made necessary by settlement, within thirty (30) days after notice from ENGINEER or OWNER at the CONTRACTOR's own expense.

3.11 CLEAN UP

Remove surplus fill materials to on-site spoil areas as directed by the OWNER's representative or resident inspector.

-- END OF SECTION --

SECTION 31 04 01 - TRENCH EXCAVATION SAFETY PROTECTION SYSTEM

PART 1 GENERAL

1.1 DESCRIPTION

- A. This item will consist of the basic requirements which the CONTRACTOR must comply with in order to provide for the safety and health of workers in a trench. The CONTRACTOR shall develop, design and implement the trench excavation safety protection system. The CONTRACTOR shall bear the sole responsibility for the adequacy of the trench safety system and providing "a safe place to work" for the workman.

1.2 GENERAL

- A. The trench excavation safety protection system shall be used for all trench excavations deeper than five (5) feet. The Excavating and Trenching Operation Manual of the Occupational Safety and Health Administration, U.S. Department of Labor, shall be the minimum governing requirement of this item and is hereby made a part of this Specification. The CONTRACTOR shall, in addition, comply with all other applicable federal, state and local rules, regulations and ordinances. The design of the trench excavation safety protection system shall be performed by or under the supervision of a professional engineer licensed to practice in the State of Texas.
- B. This project whether bid or negotiated shall have a pay item for trench safety that complies with Item 1.02.A above. Payment shall be made at the unit price per linear foot of trench excavation protection.
- C. If evidence of possible cave-ins or slides is apparent, all work in the trench shall cease until the necessary precautions have been taken by the CONTRACTOR to safeguard personnel entering the trench. It is the sole duty, responsibility and prerogative of the CONTRACTOR, not the OWNER or ENGINEER or resident inspector, to determine the specific applicability of the designed trench safety systems to each field condition encountered on the project. The CONTRACTOR shall maintain a permanent record of daily inspections.

1.3 REFERENCE STANDARDS

1.4 INDEMNIFICATION

- A. The CONTRACTOR shall indemnify and hold harmless the OWNER, their employees and agents, from any and all damages, costs, (including without limitation, legal fees, court costs, and the cost of investigation), judgments or claims by anyone for injury or death of persons resulting from the collapse or failure of trenches constructed under this project.
- B. The CONTRACTOR acknowledges and agrees that this indemnity provision provides indemnity for the OWNER and ENGINEER in case the OWNER or ENGINEER is negligent either by act of omission in providing for trench safety, including, but not limited to inspections and failure to issue stop work orders.

1.5 MEASUREMENT AND PAYMENT

- A. All methods used for a trench excavation safety protection system shall be measured by the linear foot of trench and paid at the unit price in the CONTRACTOR's schedule of values, which shall be total compensation for furnishing design, materials, tools, labor equipment, and incidentals necessary, including removal of the system. Measurement for pipeline trench excavation safety protection system shall be based on the linear feet along the centerline of the pipeline trench. Measurement for structural trench excavation safety protection system shall be based on the linear feet around the outside perimeter of the structure's walls. Where pipelines intersect structures, measurement for the pipeline shall begin/end at the outside of the structure's wall.

PART 2 PRODUCTS

2.1 NOT USED

PART 3 EXECUTION

3.1 NOT USED

-- END OF SECTION --

SECTION 31 06 01 - SITE GRADING AND EARTHWORK

PART 1 GENERAL

1.1 REFERENCE STANDARDS

- ASTM C131/C131M - Standard Test Method for Resistance to Degradation of Small-Size Coarse Aggregate by Abrasion and Impact in the Los Angeles Machine; Latest Edition.
- ASTM C535 - Standard Test Method for Resistance to Degradation of Large-Size Coarse Aggregate by Abrasion and Impact in the Los Angeles Machine; Latest Edition.
- ASTM C88 - Standard Test Method for Soundness of Aggregates by Use of Sodium Sulfate or Magnesium Sulfate; Latest Edition.
- ASTM D1557 - Standard Test Methods for Laboratory Compaction Characteristics of Soil Using Modified Effort (56,000 ft-lbf/ft³ (2,700 kN m/m³)); 2012.
- ASTM D2487 - Standard Practice for Classification of Soils for Engineering Purposes (Unified Soil Classification System); 2011.
- ASTM D4221 - STANDARD TEST METHOD FOR DISPERSIVE CHARACTERISTICS OF CLAY SOIL BY DOUBLE HYDROMETER; Latest Edition.
- ASTM D4253 - Standard Test Methods for Maximum Index Density and Unit Weight of Soils Using a Vibratory Table; Latest Edition.
- ASTM D448 - Standard Classification for Sizes of Aggregate for Road and Bridge Construction; 2012.
- ASTM D698 - Standard Test Methods for Laboratory Compaction Characteristics of Soil Using Standard Effort (12,400 ft-lbf/ft³ (600 kN-m/m³)); 2012.
- TXDOT Item 247

1.2 WORK INCLUDED

- A. General excavation and fill operations for buildings. Rough grading and contouring of site, and drainage ditches.
- B. Aggregate fill and earth fill material classifications and requirements.
- C. OWNER is responsible for payment of all soils test. ENGINEER is responsible for determining all tests necessary. CONTRACTOR is responsible for allowing time in the construction schedule for testing any required rework.

1.3 QUALITY ASSURANCE

- A. All materials to be used whether excavated on-site or imported as offsite borrow, shall be tested for compliance with the requirements of this section prior to placement.
- B. Notify OWNER and ENGINEER when bearing material (bottom of excavation) is reached for observation of founding strata.
- C. Prior to furnishing any soils to the site, CONTRACTOR shall furnish a written, notarized certification from the landowner of each proposed offsite soil borrow source stating that to the best of the landowner's knowledge and belief, there has never been contamination at the borrow source site with hazardous toxic materials.

1.4 SUBMITTALS

Submit test reports for all specified parameters for each material classification used prior to placing material and at intervals of 2000 cy during placement. Obtain representative samples from multiple locations from stockpiles for each test.

1.5 PRODUCT DELIVERY, STORAGE AND HANDLING

- A. Stockpile excavated materials and/or borrow in designated areas or in areas as approved by the ENGINEER. Do not stockpile material in the flood plain.
- B. Lightly compact and slope top of stockpiles to prevent excessive erosion and ponding of water.

1.6 PROTECTION

- A. Protect trees, shrubs, lawns, and other features remaining as portion of final landscaping.
- B. Protect benchmarks, existing structures, fences, roads, sidewalks and paving.

- C. Protect above or below grade utilities which are to remain. Do not take existing utilities out of service without specific authorization by the OWNER. Notify OWNER at least five working days prior to taking existing utilities out of service to make connections or for removal of utility.
- D. Protect excavations by shoring, bracing, sheet piling, underpinning, or other methods, as required to prevent cave-ins or loose soil from falling into excavations.
- E. Underpin adjacent structures which may be damaged by excavation work, including service lines and pipe chases.
- F. Notify the ENGINEER of unexpected subsurface conditions.
- G. Where damage could result from continuing work, discontinue work in area until ENGINEER notifies the CONTRACTOR of the required modifications.
- H. Protect bottom of excavations and soil around and beneath foundations from frost, freezing, and excessive moisture changes.
- I. Grade around excavations to prevent surface water runoff into excavated areas. During excavation, maintain grades for complete drainage. Install temporary drains or drainage ditches as needed to intercept or divert surface water and prevent interference or delay of the Work. Install groundwater pumping facilities and hoses/piping required to perform the work. The pumping of water shall be included in the appropriate lump sum bid items. No separate payment will be made for drainage control or ground water pumping.
- J. Repair damage, promptly, at no cost to OWNER.

PART 2 PRODUCTS

2.1 MATERIALS

- A. Class 1 Aggregate Fill: Consist of durable particles of crushed stone free of silt, clay, or other unsuitable materials and have a percentage of wear of not more than 40 percent when tested in accordance with ASTM C131/C131M or ASTM C535. When material is subjected to five (5) cycles of the sodium sulfate soundness test in accordance with ASTM C88, the weighted percentage of loss shall not exceed 12 percent. The source of the material shall be approved by the ENGINEER and shall meet the following gradation in accordance with ASTM D448, size number 57:

SIEVE SIZE SQUARE OPENING	PERCENT PASSING
1-1/2 inches	100
1-inch	95-100
1/2 inch	25-60
No. 4	0-10
No. 8	0-5

- B. Class 2 Aggregate Fill: Consist of durable particles of crushed or weathered limestone free of unsuitable, soft, or organic material will be considered. The source of the material shall be approved by the ENGINEER. Bin #10 or chat material complying with the following gradation requirements:

SIEVE SIZE SQUARE OPENING	PERCENT PASSING
3/4-inch	100
1/2-inch	95-100
3/8-inch	90-100
1/4-inch	65-80
No. 4	30-40
No. 20	0-5

- C. Class 3 Aggregate Fill: Consist of durable particles of crushed stone free of silt, clay, or other unsuitable material and have a percentage of wear of not more than 40 percent when tested in accordance with ASTM C131/C131M or ASTM C535. When material is subjected to five cycles of the sodium sulfate soundness test in accordance with ASTM C88, the weighted percentage

of loss shall not exceed 12 percent. The source of the material shall be approved by the ENGINEER and meet the following gradation:

SIEVE SIZE SQUARE OPENING	PERCENT PASSING
1-3/4-inch	100
7/8-inch	65-90
3/8-inch	50-70
No. 4	35-55
No. 40	15-30
No. 100	0-12
	Wet Sieve Method

- D. Crushed Limestone Base Material: Shall meet the requirements of 2004 TXDOT Item 247, Type A, Grade 2 or better.
- E. Non-Expansive Earth Fill: Consist of soil materials with a liquid limit of 35 or less, a plasticity index between 5 and 15, a minimum of 35 percent passing the No. 200 sieve, a minimum of 85 percent passing the No. 4 sieve, and which are free of organics or other deleterious materials. When compacted to the recommended moisture and density, the material shall have a maximum free swell value of 0.5 percent and a maximum hydraulic conductivity (permeability) of 1 E-05 cm/sec, as determined by laboratory testing of remolded specimens of the actual materials proposed for the non-expansive earth fill.
- F. General Earth Fill: Consist of any soil materials which have a minimum plasticity index of 8, a minimum of 20 percent passing the No. 200 sieve, a minimum of 75 percent passing the No. 4 sieve, and which are free of organics or other deleterious material. On-site soils are sometime suitable for use as general earth fill.
- G. Select Fill:
 - 1. Non-organic, sandy clay or clayey sand.
 - 2. Liquid limit less than 36.
 - 3. Plasticity index ranging from 5 to 18.
 - 4. Sieve Analysis: Maximum percent retained on No.4 sieve = 25 to 50 and on No.40 sieve = 50 to 75.
 - 5. Maximum of 70 percent passing #200 sieve.
 - 6. Maximum size of aggregate 1-3/4 inches.
 - 7. On-site soils may be blended and utilized for select fill if approved by the ENGINEER and if the blended material complies with the select fill requirements above.
- H. Sand Fill or Sandy Select:
 - 1. Granular material of uniformly graded crushed rock from 3/4-inch U.S. sieve downward.
 - 2. Plasticity Index: Maximum of 5.
 - 3. Sieve Analysis:

SIEVE NO.	MAX. PERCENT PASSING
1-inch	100
No. 10	50
No. 40	30
No. 200	8

- I. Low-Permeability Earth Fill: Consist of soil materials classified as CH or CL in accordance with ASTM D2487. The materials also shall have a minimum liquid limit of 40, a minimum plasticity index of 20, a minimum of 50 percent passing the No. 200 sieve, and shall be free of organics or other deleterious materials. The material shall have a Percent Dispersion of less than 20 when tested in accordance with ASTM D4221. When compacted to the recommended moisture and density, the material shall have a maximum hydraulic conductivity of 1 E-07 cm/sec, as determined by laboratory testing of remolded specimens of the actual materials proposed for the low-permeability fill.

- J. Unclassified Material: All material excavated from site not meeting the requirements for topsoil, or classified materials.

PART 3 EXECUTION

3.1 PREPARATION AND LAYOUT

- A. Establish extent of site grading by area and elevation; designate and identify datum elevation.
- B. CONTRACTOR shall set required lines and levels.
- C. Maintain benchmarks, monuments and other reference points.

3.2 UTILITIES

- A. Approximate locations of known underground utilities are indicated on the Drawings. The CONTRACTOR is responsible for locating all existing utilities prior to construction.
- B. Before starting excavation, the CONTRACTOR is to establish location and extent of underground utilities occurring in work area.
- C. Notify the ENGINEER for direction for removal and/or relocation of lines which are in the way of excavation.
- D. Maintain, reroute or extend as required, existing utility lines to remain which pass through work area with the approval of the OWNER.
- E. Support and protect utility services uncovered by excavation.
- F. Accurately locate and record abandoned and active lines rerouted or extended, on Project Record Documents.
- G. As excavation approaches utilities, hand excavate to uncover utilities.

3.3 EXCAVATION

- A. Before starting excavation, clear and grade work area to minimum depth shown on Plans. Strip top soil approximately 6 inches to 12 inches, depending on location and stockpile.
- B. Excavate in accordance with lines and levels required for construction of the Work.
- C. When excavation is through paved areas, cut pavement to provide a square, uniform edge with minimum disturbance of remaining pavement and replace in accordance with the Drawings.
- D. In all areas requiring rock excavation, the CONTRACTOR shall install the pipe and complete the "rock free" bedding so that the installation may be inspected prior to backfilling. The OWNER's inspector shall be notified by the CONTRACTOR when the bedding is complete for each particular segment. Any rock excavation areas backfilled without the OWNER's prior inspection will require uncovering and checking at the CONTRACTOR's expense.
- E. Machine slope banks.
- F. Hand trim excavations and leave free from loose or organic matter.
- G. Provide and maintain surface and groundwater control until backfilling is complete. Keep excavations free from standing water.
- H. Do additional excavation only by written authorization of ENGINEER.
- I. Correct unauthorized excavation as directed, at no cost to OWNER. Areas that are excavated to elevations below those shown on the Plans shall be backfilled and compacted with crushed rock (Class 3 Aggregate Fill) if area is under aggregate fill, pipe, or structure, and otherwise with non-expansive earth fill.
- J. Excavations should not interfere with normal 45 degree bearing splay of any foundation unless sheeting and/or shoring is designed and provided for excavation.
- K. Stockpile excavated material in areas designated by ENGINEER according to classifications given under materials portion of this section.
- L. Do not disturb soil within branch spread of existing trees or shrubs that are to remain.
- M. Coordinate with OWNER's representative prior to reaching founding level for foundations and prior to placing mud slabs to request observation.

3.4 COMPACTED FILL

- A. Preparation for Fill Placement:
 - 1. Do not start backfilling operations until structures have been inspected and backfilling authorized by OWNER's representative or the ENGINEER. Backfill against structures in

accordance with Section 31 02 01, STRUCTURAL EXCAVATING, BACKFILLING AND COMPACTING.

2. Ensure areas to be filled are free from debris, snow, ice and water, and that ground surfaces are not in a frozen condition.
3. Do not place fill over existing subgrade surfaces which are porous, wet or spongy.
4. Proofroll subgrade with minimum 25-ton pneumatic roller or loaded dump truck under observation of OWNER's representative. Remove soft or unstable areas and replace with select fill, then scarify subgrade to a depth of 6 inches and compact to a minimum of 95 percent of ASTM D698 at a moisture content within 3 percent of optimum moisture. Density and moisture content of the compacted subgrade shall be maintained until it has been covered with the next course of construction.
5. Place compacted fill to grades, contours, levels and elevations shown on Drawings. After dumping, spread the material in horizontal layers. Place fill in maximum 6-inch compacted lifts compacted to a minimum of 95 percent Standard Proctor (ASTM D698) at a moisture content within 3 percent of optimum moisture. Density and moisture content of each lift of fill must be maintained until the next lift is placed.
6. Existing hillsides or slopes which will receive fill should be loosened by scarifying or plowing to a depth of not less than 8 inches. The fill material shall be benched into the existing slope in such a manner as to provide adequate bonding between the fill and slope, as well as to allow the fill to be placed in horizontal lifts.
7. Fills should extend a minimum of 5 feet outside of building lines and slope to natural grade.

B. Material Placement:

1. General:
 - a. Place fill in maximum 6-inch compacted lifts compacted to a minimum of 95 percent Standard Proctor (ASTM D698) at a moisture content within 3 percent of optimum moisture. Density and moisture content of each lift of fill must be maintained until the next lift is placed. Use a method so as not to disturb or damage completed work constructed in the excavations.
 - b. If the surface is too smooth and hard to bond properly with a succeeding layer, the surface shall be roughened and loosened by disking before the succeeding layer is placed.
 - c. Where fill is to be placed next to existing fill, that fill shall be removed to unweathered, dense material. Each layer shall be benched and disked as adjoining lifts are placed. Material hauling equipment shall be so routed to prevent the formation of ruts.
 - d. The surface of the fill shall be graded to drain freely and maintained throughout construction. During the dumping and spreading process, all roots, debris and all rocks greater than 3 inches in maximum dimension shall be removed.
 - e. Following the spreading and mixing of the soil, it shall be processed by disking or pulverizing throughout its thickness to break up and reduce clod size, and provide additional blending of materials.
 - f. The moisture content of the soil shall be adjusted, if necessary, by either aeration or the addition of water to bring the moisture content within the recommended range. Water required for sprinkling to bring the fill material to the proper moisture content shall be applied evenly through each layer.
 - g. Any layers which become damaged by weather conditions shall be processed to meet recommended requirements. The compacted surface of a layer of fill shall be lightly loosened by disking before the succeeding layer is placed.

C. Compaction:

1. Compact fill materials listed below to required percentages of maximum dry density.
 - a. Compact non-expansive earth fill in top 12 inches under paving or building to a minimum of 95 percent of maximum dry density of an ASTM D1557 Modified Proctor at a moisture content with 3 percent of optimum moisture.

- b. Compact non-expansive earth fill and general earth fill not under roads or in embankment and more than 1 foot beneath roads to a minimum of 95 percent of ASTM D698 at a moisture content within 3 percent of optimum moisture.
 - c. Compact non-expansive earth fill against underground walls to between 95 and 100 percent of ASTM D698 at a moisture content within 3 percent of optimum moisture.
 - d. Place Select Fill in maximum 6-inch compacted lifts compacted to a minimum of 95 percent Standard Proctor (ASTM D698) at a moisture content within 3 percent of optimum moisture.
 - e. Minimum Frequency of Density Tests:
 - 1) Bearing: 1 test/3000 square feet per lift or minimum of 2 tests per lift.
 - 2) Structure Fills: 1 test/3000 square feet per lift, minimum 2 test per lift.
 - 3) Backfill: 1 test/6000 square feet per lift, minimum 2 tests per lift.
 - 4) Trench backfill: 1 test/150 Lf trench per lift, minimum 2 tests per lift.
 - f. The CONTRACTOR shall be responsible for the actual quality of the fill, in place. Satisfactory test results shall not be considered as the sole factor of the quality of the fill operation.
 - g. The moisture content and density of all fill shall be maintained at the specified range of moisture and density.
2. Compact aggregate fill material in maximum 6-inch thick lifts.
 - a. Aggregate fill for pipe bedding shall be compacted to a minimum of 95 percent of maximum density as determined by ASTM D4253. The moisture content shall be in a range that will accommodate efficient placement and compaction.
 3. Prior to placement of aggregate base course material for paved areas, remove soft or unstable areas and replace with aggregate base course material, then scarify subgrade to a depth of 6 inches and compact to a minimum of 95 percent of ASTM D698 at a moisture content within 3 percent of optimum moisture. Density and moisture content of the compacted subgrade shall be maintained until it has been covered with base course material.

3.5 SUBGRADE

- A. The CONTRACTOR shall excavate or fill to the top of proposed subgrade so that the specified thickness of base course material will be obtained across the section. After excavation or fill has been made to the subgrade elevation as shown on the Plans, the CONTRACTOR shall prepare the subgrade for compaction by scarifying and diking the subgrade a minimum of 6 inches and a maximum of 8 inches. Water shall be added to the soil if necessary, and the soil disked again to obtain a uniform moisture content throughout the depth of the subgrade. Moisture of the compacted subgrade shall be at optimum moisture content or at a tolerance of +/- 3%, which will be determined by soil laboratory analysis. If it is determined the moisture content is not uniform or within the limits specified, water shall be added and the subgrade disked again; or the soil shall be disked to the extent necessary to dry the soil to the specified limits, all at the CONTRACTOR's expense.
- B. After the subgrade has been prepared to the specified moisture content, subgrade shall be compacted for the full street section to 95% per ASTM D698 for a depth of 6 inches. Any areas of subgrade failing to meet the specified density shall be re-disked and recompacted until the correct density is obtained, all at the CONTRACTOR's expense. If determined by the ENGINEER or City Representative, a minimum of one density test per 6,000 square feet shall be made by an independent soil testing laboratory for Quality Control of the finished work.
- C. Compaction of the subgrade shall be performed with sheep foot rollers, pneumatic rollers and flat steel wheel rollers to the extent necessary to obtain the specified soil density. Final compaction shall be made by flat steel wheel rollers or pneumatic tire rollers to leave a smooth surface on which to install the base course material.
- D. The subgrade shall be shaped with a self-propelled grader, and all holes, ruts and depressions filled with an approved material and rolled to the extent directed by the ENGINEER. The surface of the subgrade shall be finished to the required lines and grade; and any deviation in

excess of 1/4 inch, when checked with a 16 foot straight edge, shall be corrected by the CONTRACTOR.

3.6 SCHEDULE

- A. General Earth Fill:
 - 1. Use under seeded areas, backfill at depths of more than 5 feet below and 5 feet outside of roads and in embankments (except for clay liner material) unless, otherwise shown on Drawings.
 - 2. Fill to within 4 inches of finished grade as backfill adjacent to structures.
- B. Non-Expansive Earth Fill: Use as backfill for the top 5 feet depth under roads as shown on Drawings. Use to 5 feet outside the limits of roads.
- C. Low Permeability Earth Fill: Use for top 2 feet of interior slope of embankments.
- D. Select Fill: Use as backfill against structure walls and beneath structures.
- E. Class I Aggregate Fill: Use for over excavated areas under structures and as otherwise shown on Drawings.
- F. Class 2 Aggregate Fill: Use for pipe embedment and initial backfill per details in the Plans.
- G. Sand Fill: Use for small pipe embedment (#2-inch diameter).
- H. Topsoil: Use within limits of seeded areas after substantial completion of construction and other fill has been placed.
- I. Unclassified Material: Dispose of on-site as directed by the OWNER.

3.7 TOLERANCES

- A. Site grading to conform to Plans within the following tolerances:
 - 1. Drainage ditches: 0.10 feet.
 - 2. Excavations: plus zero to -0.10 feet.
 - 3. Compacted fill: 0.10 feet.

3.8 SURPLUS MATERIAL

- A. Dispose of unclassified material, surplus fill materials and excess topsoil on-site as directed by the OWNER.
- B. Leave stockpile areas and entire jobsite clean and raked, ready to receive seeding.

3.9 WATER INJECTION

General specifications for water injection under the new building are included below. Compliance with this Specification is essential. The injection depth is a minimum of 10 feet below existing grade.

- A. Injection process shall be observed on a full-time basis by a qualified inspector under the direction of the OWNER's designated geotechnical ENGINEER.
- B. A surfactant (wetting agent) shall be added to the water. The amount of surfactant used should be in accordance with the manufacturer's recommendations.
- C. The lower portion of the injection nozzle shall consist of a hole pattern that will uniformly disperse the water throughout the entire depth.
- D. Injection pressures should be adjusted to disperse as large a volume of water as possible within a pressure range of 50 to 200 pounds per square inch.
- E. Injection pipe shall be forced downward (not jetted or washed) in 12 to 18 inch intervals, injecting to refusal at each interval. For an injection depth of 10 feet a minimum of 7 intervals shall be used and for an injection depth of 5 feet a minimum of 4 intervals shall be used. Refusal will be determined on site by the inspector.
- F. Spacing for the injections not to exceed five feet on center each way, and injections shall be carried at least five feet outside building lines. Subsequent injections should be offset from initial locations in a pattern that maximizes distribution of the mixture.
- G. After the recommended number of injection passes the moisture content of the soils shall be evaluated by the OWNER's designated geotechnical ENGINEER on the basis of laboratory tests on tube samples (not cuttings) obtained from borings under his supervision following a

twenty-four-hour curing period. This ENGINEER shall develop recommendations on the need for any additional injections.

- H. In the event that more than three injections passes are required, the surface of the injected area shall be scarified to a depth of at least eight inches and re-compacted prior to the next injection.
- I. The surface of the injected area should be sealed or otherwise protected against moisture loss as soon as possible after acceptance of the water injection process.

3.10 MAINTENANCE

Following the final shaping of material, the base course shall be maintained throughout its entire length by the use of a standard road machine or motor grade and rollers until such time as, in the judgment of the ENGINEER, base course meets the required density, is properly bonded and is suitable for priming. The base shall be properly drained at all times. During this maintenance period, any deficiencies in thickness, composition, smoothness or density shall be corrected in a satisfactory manner.

The CONTRACTOR shall be fully responsible for maintaining and preserving the completed base course during the period prior to surface treatment. Upon completion of the base course, if the asphaltic surface cannot be applied, the CONTRACTOR shall apply an emulsion of primer coat to the base surface in order to afford dust control and assist in base maintenance.

CONTRACTOR shall return to the project as often as required to fill holes in the base surface and add primer as required or recommended by the ENGINEER.

-- END OF SECTION --

SECTION 33 01 01 - GENERAL REQUIREMENTS FOR PIPING SYSTEMS

PART 1 GENERAL

1.1 REFERENCE STANDARDS

- ASTM E84 - Standard Test Method for Surface Burning Characteristics of Building Materials; 2016.
- COE CRD-C 572 - Corps of Engineers Specifications for Polyvinylchloride Waterstop; 1974.
- MSS SP-58 - Pipe Hangers and Supports - Materials, Design, Manufacture, Selection, Application, and Installation; 2009.
- MSS SP-69 - Pipe Hangers and Supports - Selection and Application; 2012.
- NSF 61 - Drinking Water System Components - Health Effects; 2014 (Errata 2015).

1.2 WORK INCLUDED

- A. All exposed, submerged and buried plant and station piping including modifications to existing systems as well as new pipe systems.
- B. Potable water and raw water mains, sanitary sewers, storm drains and culverts shown on Drawings.

1.3 RELATED WORK

- A. Section 31 03 01 TRENCHING, BACKFILLING AND COMPACTING
- B. Division 33 UTILITIES

1.4 QUALITY ASSURANCE

- A. All material may be rejected for failure to meet any of the requirements of this specification. Material rejected by the ENGINEER shall be removed from the site.
- B. Inspection: The quality of all materials, process or manufacture and the finished installation shall be subject to the inspection and approval of the ENGINEER.
- C. All surfaces and materials in contact with water, or in contact with a chemical being added to water that is being treated for potable use, shall conform to NSF/ANSI 61 and be certified by an organization accredited by ANSI, or shall meet the TCEQ requirements for contact with potable water.
- D. The use of pipes and pipe fittings that contain more than 8.0% lead or solders and flux that contain more than 0.2% lead is prohibited.

1.5 DESCRIPTION OF PIPING SYSTEMS

- A. The configuration and layout of yard, process, and station piping systems are shown on the Drawings.
- B. The type of pipe and joints, and embedment (if buried) to be used for each system are shown on the Drawings or included in the appropriate Specifications.
- C. In certain locations, pipe supports, anchors, and expansion joints have been indicated on the Drawings, but no attempt has been made to indicate every pipe support, anchor, and expansion joint. It shall be the CONTRACTOR's responsibility to provide a complete system of pipe supports, to provide expansion joints, and to provide restraints and anchor all piping, in accordance with the requirements set forth herein. Additional pipe supports may be required adjacent to expansion joints, couplings, or valves.
- D. Pipe and fittings shown on yard piping Drawings are general in nature. CONTRACTOR shall determine exact lengths and fittings required and make field adjustments necessary to complete piping and avoid conflicts. Changes to Plans and profiles of piping shall be submitted to ENGINEER for approval. Pipe and fittings not incorporated into the project shall remain the property of the CONTRACTOR. Costs will not be paid by the OWNER for materials not used in the project, even if shown on the Drawings. Additions and deletions to the scope shall be incorporated by Change Order.

1.6 SUBMITTALS

- A. Shop Drawings and Product Data:
 - 1. Comply with the provisions of Section 01 04 01 and the supplemental requirements below.

2. Submit detailed layout drawings for all piping systems. Those drawings may be organized by system or by areas. Prepare drawings to scale and show the following information on them:
 - a. Type of piping including material, weight, linings, and coatings. If desired, use code and key to product data sheet specified below.
 - b. Location and type of joints, fittings, taps, supports, restraint systems, kickers and blocking (as applicable).
 3. Submit fabrication drawings for specials including fabricated fittings, wall pipes and wall sleeves. Show dimensions and materials of construction.
 4. Submit manufacturer's standard drawings showing dimensions, configuration and materials of construction for the following items:
 - a. Joints.
 - b. Flanges.
 - c. Couplings.
 - d. Expansion joints.
 - e. Hangers, brackets and other similar accessories.
 5. Submit the following product data on all piping materials.
 - a. Reference standard.
 - b. Type material.
 - c. Wall thickness, schedule or class as appropriate.
 - d. Outside diameter.
 - e. Type and thickness of lining.
 - f. Type and thickness of coating.
 - g. Pressure rating, if applicable.
- B. Affidavits of Compliance:
1. Submit manufacturer's affidavits of compliance with the reference standards.
- C. CONTRACTOR shall mark actual flowline or top of pipe elevations and actual coordinates on record drawings when pipelines are being installed.

1.7 DELIVERY, STORAGE AND HANDLING

- A. General: Comply with manufacturer's instructions.
- B. Delivery and Handling:
1. Do not deliver piping materials to project site prior to ENGINEER's approval of required submittals.
 2. Unload and handle piping materials using proper materials handling equipment.
 3. Do not drop, roll, skid piping materials.
 4. Take such additional precautions as necessary to avoid damaging piping materials and coatings thereon.
- C. Storage:
1. Store piping materials in a manner which will reduce risk of damage.
 2. Block piping materials to prevent rolling.
 3. Protect materials from weather and sun as recommended by the manufacturer.

PART 2 PRODUCTS

2.1 GENERAL

- A. See other Sections in Division 33 for piping materials specifications.
- B. No asbestos materials shall be used in any piping materials, linings, and gaskets for this project.
- C. PVC piping shall not be used beneath structures except for chlorine gas and chemical service. Where PVC pressure pipe is called out for a system, furnish continuous copper tubing for less than 4-inch diameter and DIP for 4 inches and larger sizes. Transition 3 feet outside slabs and 1-foot above slabs unless otherwise shown. All piping beneath slabs and to 2 feet outside of slab shall be concrete encased.

- D. Gravity drain systems beneath slabs shall be ductile iron except for chemical drains, unless shown specifically on the Plans. Encase all piping beneath slabs.
- E. All buried potable water piping installed in this project shall have metal detectable tape indicating "Potable Water Line" installed 12 inches above the pipe.
- F. Install cleanouts on sludge piping so that all runs between bends may be accessed and at intervals not exceeding 250 feet on straight runs. Refer to Standard details.
- G. All bolts and fasteners on buried fittings and valves and fittings and valves in manholes shall be 304 stainless steel. Buried MJ fitting bolts may be Corten. Bolts and fasteners on submerged fittings and valves shall be 316 SS.
- H. For buried pipes, provide a flexible joint (Dresser coupling or push on or mechanical joint) within 10 feet from a structure connection to allow differential movement. Provide proper restraint on pressure systems.
- I. Provide taps and connections for flushing, testing, and disinfecting pipeline systems.
- J. Provide taps or weld-u-lets with stainless steel ball valves and piping at all high points in the piping systems for addition of air valves.

PART 3 EXECUTION

3.1 GENERAL INSTALLATION REQUIREMENTS

- A. Install all piping systems in accordance with the Drawings, Technical Specifications, approved shop drawings and manufacturer's installation instructions at CONTRACTOR's expense.
- B. Examine all piping materials prior to installation and replace items that are damaged or otherwise defective.
- C. Thoroughly clean inside of all piping, valves, and accessories, and outside of all materials which will be exposed. Clean before installation and maintain in that condition until accepted by OWNER.
- D. Provide secure temporary caps or inflatable plugs at all pipe ends at the end of each day to prevent foreign material from entering the piping systems. Brace pipe to restrain from floating.
- E. Do not modify structures, equipment, or piping for the purpose of installing piping unless specifically authorized by the ENGINEER.
- F. All piping systems shall be cleaned and tested prior to making connections at structures and to existing pipe systems. Small diameter pipes shall be flushed and large diameter pipes shall have mandrels pulled or other acceptable verification furnished that pipes are clean and no construction debris remains. Temporary blocking and forms used to grout inverts and blockouts shall be removed and manholes and pipes shall be tested before payment will be approved for the last 10 percent of the respective pipe pay estimate items.
- G. CONTRACTOR shall be responsible for, development, and comply with the trench safety plan and a confined space entry plan.
- H. Where indicated on the Plans, the CONTRACTOR shall furnish and install Polyvinyl Chloride (PVC) plastic water stops, Sealtight, Duo-PVC water stops as manufactured by W.R. Meadows, Inc., Electrovert, Inc., or approved equal. The water stops shall meet the requirements of COE CRD-C 572 for PVC water stops. The water stops shall be 9" or 6" width as shown on the Plans and shall have a minimum web thickness of 3/8". The PVC water stops shall be of the "U" bulb design or center circle design, having a minimum inside diameter 3/4.

3.2 INSTALLATION OF BURIED PIPING SYSTEMS

- A. Line and Grade:
 - 1. Install piping to lines and grades shown on Drawings or as stated.
 - 2. Temporary support, adequate protection and maintenance of all underground utilities such as gas service, poles, guy wires, drains, sewer or any other underground utility shall be furnished by the CONTRACTOR at his own expense whether or not such services are shown on the Plans.
 - 3. Slope piping uniformly between flowline elevations shown.

4. If centerline and flowline elevations are not shown on Drawings, install piping so that there is at least 30 inches of cover over same, except under ditches where the minimum cover is to be 24 inches. Piping less than 4-inch diameter may be installed with 3 feet of cover.
 5. Comply with requirements for minimum and maximum trench widths shown in the Plans. If maximum trench width is exceeded, use next higher class of embedment at no additional cost.
 6. Refer to special detail for installation of chemical and small diameter PVC piping.
 7. Service lines shall have a minimum cover of 24-inches.
 8. The top of the water line must be located below the frost line and in no case shall the top of the water line be less than 24 inches below the ground surface.
- B. Dewatering:
1. Keep trenches free of water when performing any type of work in them.
 2. Discharge groundwater from construction pumps as directed by OWNER.
- C. Bedding:
1. Install bedding as shown on Drawings. Shape bedding to allow for coupling and bells and to provide support over full length of pipe section. Place embedment under haunches and on sides of pipe and compact in lifts and in a manner which does not disturb pipe from line and grade.
 2. If bedding is not called for on Drawings or Specifications, piping less than 4-inch diameter shall be installed and encased in sand or granular material. Use embedment type shown in the standard details for larger pipes.
 3. Provide concrete encasement for all pipe under structures and to 2' beyond structure and as shown on Drawings.
 4. Provide concrete cradle (Class V) Embedment to first pipe joint at all connections to structures unless otherwise shown.
- D. Laying of Pipe:
1. Do not drop or roll pipe into trench. Inspect thoroughly prior to laying and then place carefully by hand or materials handling equipment.
 2. Do not lay pipe in water.
 3. Lay bell and spigot type piping with bell end facing direction of laying which is normally upgrade.
 4. Joint pipe as specified in piping material specifications.
 5. Do not deflect pipe unless shown on Drawings or approved by ENGINEER.
 6. When deflection of pipe is authorized, do not exceed the manufacturer's recommended maximum deflection.
 7. Shoring or other trench safety systems utilized shall be of thin cross-section such that when the sections are pulled, the embedment is not disturbed or displaced.
- E. Encasement of Piping and Valves:
1. Provide polyethylene encasement for steel, RCCP, cast iron and ductile iron piping and valves.
 2. Comply with Section 31 03 01, TRENCHING, BACKFILLING AND COMPACTING, for embedment of PVC pipe.
 3. Embedment shall extend at least eight inches above pipe and four inches below Pipe.
 4. Use Class C concrete or flowable fill when concrete encasement is called for on Drawings. Such encasement to extend a distance of Pipe OD/6 with a minimum of six inches from pipe in all directions unless otherwise noted on Drawings.
- F. Concrete Blocking:
1. Concrete thrust blocking shall be used for all buried piping two inches in diameter and larger that is under pressure.
 2. Provide thrust and restraint blocks at all bends, tees, wyes, hydrants, valves, and plugs.
 3. Use Class B concrete or thoroughly mixed sacrete if approved by ENGINEER.
 4. Place concrete against undisturbed firm earth.

5. Area of concrete in contact with earth to be as required to prevent pipe movement at specified field test pressure or working pressure plus surge allowance.
 6. Provide thrust blocking on back side of tees on pressure lines without adequate length to restrain joints.
 7. No blocking shall be covered up until it has been inspected and approved by the OWNER's representative or resident inspector. If covered prior to inspection, the CONTRACTOR shall uncover the blocking for inspection at his expense.
- G. Restrained Joints:
1. Use restrained joint piping and fittings for all mechanical joint fittings and valves under pressure. Joint restraint shall be provided for test pressures shown on the Plans and Specified for each piping system with a safety factor of 1.5 minimum, except for the following: The potable water, service water, and high service pump discharge pipes restraint design shall account for surge pressure based on 6 fps velocity in addition to working pressure shown on the Plans and safety factor of 1.5.
 2. Joint Restraints shall be Megalug Joint Restraints as manufactured by EBAA Iron, or approved equal.
- H. Backfilling:
1. Comply with Section 31 03 01, TRENCHING, BACKFILLING AND COMPACTING, and the following supplemental requirements.
 2. Backfill as soon as practicable after installation of piping, valves, encasement, restraint and blocking.
 3. Touch up damaged protective coatings prior to backfilling.
 4. Exercise care to avoid damaging piping or protective coatings with tamping equipment.
 5. When authorized by the ENGINEER, sheeting and bracing may be left in trench. Cut off all members so that tops of same are at least 18 inches below ground. Sheeting and bracing left in place shall be indicated on Record Drawings.
- I. Connections to New Manholes:
1. Couplings for pipe connections shall be cast into the manhole walls. PVC sleeves with rubber gaskets and abrasive silica outer coating may also be utilized.
 2. All clamps shall be 316 stainless steel.
 3. Support manhole connection to first pipe joint with concrete cradle.
- J. Making Field Connections to Manholes (when approved by ENGINEER):
1. Cut neat opening in manhole no larger than necessary to insert pipe.
 2. Utilize PVC sleeves with rubber gaskets and abrasive silica outer coating. After installing new lines, place concrete collar around pipe on outside of manhole to seal joint. Make collar approximately 8 inches wide by 8 inches deep. Use Class B concrete.
 3. Modify invert channel in manhole to provide smooth transition into or out of new pipe. Use Class B concrete.
- K. Valves:
1. Provide restrained joints on buried valves. Flanges may be utilized for valves 12 inches and larger when approved by the ENGINEER.
- L. Testing:
1. Comply with Section 33 01 02, FIELD TESTING OF PIPING SYSTEMS, and pipe Specifications and Drawings.

3.3 INSTALLATION OF EXPOSED PIPING SYSTEMS

- A. Alignment and Elevation:
1. Install straight runs true to line and elevation.
 2. Install vertical pipe truly plumb in all directions.
 3. Install piping parallel or perpendicular to building walls. Piping at odd angles and 45 degree runs across corners will not be accepted unless specifically shown on Drawings.

4. Install small diameter piping generally as shown on Drawings when specific locations and elevations are not indicated. Locate such piping as required to avoid ducts, equipment, beams, etc.
 5. Install piping so that pipe, flanges, valves, and associated appurtenances are at least eight feet above finish floors, stairs, and landings unless lesser clearances are specifically dimensioned on the Drawings.
 6. Bring piping to alignment and elevation without forcing or springing pipe.
 7. For PVC or CPVC or ABS piping runs of 10 feet or longer, provide supports that accommodate expansion and contraction without bending the pipe out of alignment.
- B. Joints:
1. Joint pipe in accordance with piping material specifications and the supplemental requirements below.
 2. Wire brush flange faces and threads before jointing.
 3. Bring piping to proper alignment and elevation with permanent support system before tightening flange bolts and nuts.
- C. Unions for Threaded Piping:
1. Install unions near threaded valves and equipment to facilitate assembly and disassembly of piping, in addition to the specific locations shown on Plans.
 2. Install dielectric unions wherever dissimilar metals are joined.
- D. Expansion Joints:
1. Install in accordance with Drawings, Specifications for expansion joints and approved shop drawings.
 2. Use of additional couplings and adaptors to be approved by ENGINEER prior to installation.
 3. All expansion joints shall be restrained.
- E. Flexible Couplings and Flanged Coupling Adaptors:
1. Install in accordance with Drawings, Specifications for couplings and adaptors, and approved shop drawings.
 2. CONTRACTOR may use couplings and adaptors over and above those shown on Drawings to facilitate installation of piping. Use of additional couplings and adaptors to be approved by ENGINEER prior to installation.
 3. All flexible couplings and flanged coupling adaptors shall be restrained.
- F. Piping Supports and Restraints:
1. General:
 - a. Restrain, block, brace, support, or suspend pipe and fittings to prevent displacement, vibration, sagging, warping, deformation, or failure of piping and fittings, and to allow for expansion and contraction.
 - b. Support and restrain piping so that no piping loads from weight or thrust will be imparted to pumps or other equipment.
 - c. Materials: Unless otherwise specified, all pipe supports shall comply with MSS SP-58 and MSS SP-69. Materials of construction for fabricated steel supports are covered in the structural steel section. All pipe support materials shall be packaged as necessary to ensure delivery in satisfactory condition.
 - d. Unless otherwise specified or indicated on the Drawings, pipe supports shall be fabricated of manufacturer's standard materials and provided with manufacturer's standard finish.
 - e. Except as specified herein, the use of supports which rely on stressed thermoplastic components to support the pipe will not be acceptable. PVC pipe 4 inches and smaller, interior locations and exterior chemical storage area locations, shall be supported by pultruded vinylester channel and components as specified below:
 - 1) Material: Vinylester Fiberglass, Class 1 Fire Rated per ASTM E84, Premium Grade, pultruded channel as manufactured by Entrum Industries, Strut Tech

Series 200 or equal. Support system shall be as specified herein and as recommended by the manufacturer.

- 2) Adjustable strap type pipe clamps are not acceptable. Any metal components, if required, for this type support system shall be Type 316 stainless steel.
 - f. Contact between dissimilar metals, including contact between stainless steel and carbon steel, shall be prevented. Supports for brass or copper pipe or tubing shall be copper plated. Those portions of pipe supports which contact other dissimilar metals shall be rubber or vinyl coated.
 - g. All pipe supports, fasteners, anchors and hardware in wetwells, manholes, vaults, pipe trenches and submerged locations shall be AISI Type 316 stainless steel. Stainless steel supports fabricated by welding shall be AISI Type 316L material.
- G. Supports for Horizontal Piping and Spacing of Expansion Joints:
1. Location: Unless closer spacing is indicated on the Drawings, the maximum spacing for pipe supports and expansion joints shall be:

<u>Type of Pipe</u>	Pipe Support Max Spacing, Feet	Max Run Without Expansion Joint, Loop, or Bend (Note a), Feet	Expansion Joint Max Spacing (Note b), Feet
Cast Iron	15	80	80
Cast Iron, glass-lined	12	80	80
<u>Steel for hot water heating</u>			
1-1/4 inch and smaller	7	30	100
1-1/2 inch to 4 inch	10	30	100
Over 4 inch	15	30	100
<u>Steel for other services</u>			
1-1/4 inch and smaller	7	30	100
1-1/2 inch to 4 inch	10	30	100
Over 4 inch	15	80	80
<u>Stainless Steel</u>			
1-1/4 inch and smaller	7	30	100
1-1/2 inch to 4 inch	10	30	100
Over 4 inch	15	80	80
<u>Copper for hot water</u>			
1 inch and smaller	5	20	100
Over 1 inch	7	20	100
<u>Copper for other services</u>			
1 inch and smaller	5	--	--
Over 1 inch	7	50	100
<u>CPVC, PVC, and ABS Schedule 80</u>			
1/8 inch and 1/4 inch	continuous support	20	60
1/2 inch	3-1/2	20	60
3/4 inch	4	20	60
1 inch and 1-1/4 inch	4-1/2	20	60
1-1/2 inch and 2 inch	5	20	60
2-1/2 inch	5-1/2	20	60
3 inch	6-1/2	20	60

4 inch	7	20	60
6 inch	8	20	60
8 inch	9	20	60
10 inch	9-1/2	20	60
12 inch	10	20	60
<u>Polypropylene</u>	6	--	--
<u>Cast Iron Soil</u>	10	--	--
<u>PVC, Schedule 40</u>			
1/2 inch	3-1/2	20	60
3/4 inch and 1 inch	4	20	60
1-1/4 inch and 1-1/2 inch	4-1/2	20	60
2 inch	5	20	60
2-1/2 inch	5-1/2	20	60
3 inch	6	20	60
4 inch	6-1/2	20	60
6 inch	7-1/2	20	60
8 inch	8	20	60
10 inch	8-1/2	20	60
12 inch	9-1/2	20	60

NOTES:

- a. Unless otherwise permitted, an expansion joint shall be provided in each straight run of pipe having an overall length between loops or bends exceeding the maximum run specified herein.
 - b. Unless otherwise permitted, the spacing between expansion joints in any straight pipe run shall not exceed the maximum spacing specified herein.
 - c. Expansion joint fittings shall be as specified in the pipe joint and expansion joints section.
 - d. Correction factors shall be applied to the above table as recommended by the manufacturer to adjust for fluid specific gravities other than 1.0.
 - e. Maximum allowable spacing for PVC pipe shall be reduced when required by manufacturer's recommendations for maximum fluid temperatures.
2. Locate hangers or supports immediately adjacent to or at any change in piping direction, on both sides of valves, couplings, and heavy fittings, and on either end of pipe sections being removed unless specifically noted otherwise on Drawings.
 3. Install all hangers and supports so as not to interfere with the free expansion and contraction of the pipe.
 4. When hangers are used to support insulated piping, provide shields to protect insulation.
 5. Provide concrete supports as shown on Drawings, or when required to comply with these Specifications. Construct in accordance with concrete Specifications and details shown on Drawings.
 6. Rubber hose and flexible tubing shall be provided with continuous angle or channel support, except at injector and chemical feed pump locations.
 7. Unless otherwise indicated on the drawings or permitted by the ENGINEER, piping shall be supported approximately 1-1/2 inches out from the face of walls and at least 3 inches below ceilings.
 8. Concrete inserts or L-shaped anchor bolts shall be used to support piping from new cast-in-place concrete. Capsule anchors shall be used to fasten supports to existing concrete and masonry. Design loads for inserts, brackets, clamps, and other support items shall not exceed the manufacturer's recommended loads.
 9. Pipe supports shall be manufactured for the size and type of pipe to which they are applied. Strap hangers will not be acceptable. Threaded rods shall have sufficient threading to permit the maximum adjustment available in the support item.

10. Anchorage shall be provided to resist thrust due to temperature changes, changes in diameter or direction, or dead ending. Anchors shall be located as required to force expansion and contraction movement to occur at expansion joints, loops, or elbows, and as required to prevent excessive bending stresses and opening of mechanical couplings. Anchorage for temperature changes shall be centered between elbows and mechanical joints used as expansion joints. Anchorage for bellows type expansion joints may be located adjacent to the joint.
 11. Pipe guides shall be provided adjacent to bellows type expansion joints. Guides will not be required when mechanical couplings are permitted as expansion joints. Guides shall be placed on both sides of expansion joints except where anchors are adjacent to the joint. Unless otherwise indicated on the Drawings, one guide shall be within four pipe diameters from the joint and a second guide within 14 pipe diameters from the first guide. Pipe supports shall allow adequate movement; pipe guides shall not be used for support. Pipe guides shall be installed as recommended by the manufacturer.
- H. Drain Valves and Air Bleed Valves:
1. Provide drain petcocks 1/4-inch diameter opening at all low points in air piping.
 2. Provide air bleed valves 1/8-inch diameter opening at all high points in force mains unless specifically indicated otherwise.
- I. Supports for Vertical Piping:
1. Support in accordance with Drawings and approved shop drawings.
 2. For piping 4 inches and smaller, install riser clamps so as to support piping at each floor sleeve.
 3. Use at least 3/4-inch of nonshrink grout in setting base elbows and tees. See Section 03 05 01, GROUT, for nonshrink grout requirements.
 4. For piping larger than 4 inches, locate supports at change of direction, at both sides of valves and couplings, and at maximum spacing of 10 feet.
- J. Piping Restraints:
1. Provide kickers and mechanical restraint system as shown on Drawings and required herein.
 2. Use at least 3/4-inch of nonshrink grout between kickers and walls or floors and between piping supports and floors or walls unless otherwise shown on Drawings. See Section 03 05 01, GROUT, for nonshrink grout requirements.
- K. Supports for Valves:
1. Provide supports for valves 16 inches and larger. Use the type of support shown on Drawings. If type is not shown, use concrete cradle type. CONTRACTOR may utilize an alternate type if acceptable to the ENGINEER.
 2. Install floor stands as shown on Drawings and as recommended by the manufacturer.
 3. Provide lateral restraints for extension bonnets and extension stems as shown on Drawings and as recommended by the manufacturer.
 4. Provide sleeves where operating stems pass through floor.
 5. Place approved asphalt fill in recessed areas as shown on Drawings where flush bottom sluice gates or special valve installations are indicated. Size recessed areas as recommended by valve or gate manufacturer. Compact fill after placement.
 6. Install valve boxes so that they will not transmit shock or stress to valve and will be centered and plumb over the operating nuts.
- L. Wall Fittings:
1. Wall fittings shall be as shown on the Plans and the standard detail sheets.
 2. Wall fittings shall match the wall thickness, pipeline diameters, and connection types specified for the applicable pipeline designation.
- M. Field Painting: Comply with Section listed.
1. Buried Piping: Ductile iron, cast iron and steel coatings per Sections 33 01 03, DUCTILE IRON PIPE, and 33 01 04, STEEL PIPE AND FITTINGS, as applicable.

2. Exposed Piping: Paint all exposed piping, supports, fittings and valves except stainless steel and fiberglass in accordance with Section 09 03 01, COATINGS & PAINTING FOR WATER TREATMENT PLANTS.
- N. Pipe Testing.
Comply with Section 33 01 02, FIELD TESTING OF PIPING SYSTEMS, and pipe Specifications.
- O. Insulation and Heat Trace
Insulate all exposed pipes 8-inch and smaller and where specifically called for on the plans.

-- END OF SECTION --

SECTION 33 01 02 - FIELD TESTING OF PIPING SYSTEMS

PART 1 GENERAL

1.1 WORK INCLUDED

- A. Provide all necessary labor, materials and equipment, including test pumps and gauges, as well as temporary valves and piping to perform the testing operations of piping systems as specified herein.
- B. If demonstrated workmanship on one or more tests show that lines are sufficiently watertight, the ENGINEER may waive remaining testing on any given type or section of line.
- C. CONTRACTOR's Responsibility:
 - 1. Take such precautions as required to prevent damage to lines and appurtenances being tested.
 - 2. Repair any damage resulting from tests.
 - 3. Repair and retest all items which do not pass the tests as specified herein.
 - 4. Conduct all tests in the presence of the Resident Inspector, and to the satisfaction of the ENGINEER and all State and local authorities having jurisdiction.
 - 5. All necessary pumps, water, pipe connections, meters, gauges, and any necessary apparatus to perform and conduct the tests shall be furnished by the CONTRACTOR. CONTRACTOR shall furnish all necessary equipment and make all tests at CONTRACTOR's expense without separate measurement and payment, but said expense shall be subsidiary to installation of pipe.
- D. Test pressures are shown on the Plans. If not shown, refer to schedule at end of this section.
- E. Water used for testing shall be potable water only, unless approved by OWNER.

1.2 REFERENCE STANDARDS

AWWA C605 - Underground Installation of Polyvinyl Chloride (PVC) and Molecularly Oriented Polyvinyl Chloride (PVCO) Pressure Pipe and Fittings; 2013.
AWWA M23 - PVC Pipe - Design and Installation; 2002.

1.3 SUBMITTALS

- A. Submit information and data describing proposed testing methods, procedures, pressures, time periods, schedule, and apparatus for ENGINEER's record, prior to testing.
- B. Conform to any other applicable requirements of Section 01 04 01, SUBMITTALS.
- C. Submit a certified test report for each test to ENGINEER certifying the date tests were performed, names of the people in attendance, brand name of the pipe and pressure rating, the location of the joint or section tested, the test pressures at the start and end of each test, duration of the test, leakage and pertinent observations and comments.

1.4 GENERAL SEQUENCE OF WORK

- A. Obtain the OWNER's approval of proposed testing methods, procedures, and apparatus, before performing any test.
- B. Upon receipt of the OWNER's approval, submit a schedule of testing dates and times at least 24 hours in advance of testing.
- C. Perform tests as specified herein.

1.5 DEFINITIONS

- A. "Gravity lines" shall refer to CCFRP, PVC, clay pipe, reinforced concrete (non-cylinder type) pipe, and other such pipes designed to normally operate in a partially full condition.
- B. "Pressure lines" shall refer to all pipes indicated as such in the plans and in general to ductile iron, PVC, RCCP, steel, and other such pipes designed to operate in a full condition, with the system's energy grade line more than 20 feet above the top of the pipe during normal operating conditions.

PART 2 PRODUCTS

2.1 TEST EQUIPMENT

Test equipment shall be selected, obtained, and maintained by the CONTRACTOR. All gauges shall be calibrated prior to beginning testing and as often as is necessary to provide accurate, reliable information.

PART 3 EXECUTION

3.1 TESTING OF PRESSURE LINES

A. General:

1. Allow concrete blocking to cure for at least 7 days before testing.
2. Backfill and compact soil behind all blocking.
3. Backfill over pipe to extent necessary to restrain the piping. Backfill shall extend to within 1-foot of proposed final grade.
4. Conduct water leakage test after completing hydrostatic pressure tests.
5. Lines which fail to hold the specified test pressure for at least four hours or which exceed an allowable leakage rate specified below, shall be repaired to the satisfaction of the ENGINEER and retested at the CONTRACTOR's expense.

B. Procedures for Leakage and Hydrostatic Pressure Tests:

1. Slowly fill isolated section of line with water.
2. Insure that all air has been expelled through air and vacuum release valves, taps, or connections shown on Plans for permanent piping, valves, or accessories. Do not make additional taps solely for air expulsion purposes unless approved by ENGINEER. No additional compensation will be made for additional taps.
3. Apply test pressure at 1.5 times the working pressure or rated pressure of the pipe, whichever is greater. Duration of test shall be four hours.
4. Allow concrete pipe to stand full of water at least 12 hours before starting leakage test.
5. For HDPE pipe the test procedure consists of initial expansion, and test phases. During the initial expansion phase, the test section is pressurized to the test pressure, and sufficient make-up water is added each hour for three (3) hours to return to test pressure. After the initial expansion phase is complete then the four (4) hour test phase can begin.
6. At the end of the four-hour test, the entire route of the pipeline shall be inspected to locate any leaks or breaks. Any defective joints, cracked or defective pipe, fittings, or valves discovered in consequence of this pressure test shall be removed and replaced with sound material in the manner provided and the test shall be repeated until satisfactory results are obtained. Any and all noticeable leaks shall be repaired regardless of whether the actual leakage is within the allowable. The pipe shall be tested again for a period of four hours.
7. All pipe shall be tested for leakage by a hydrostatic pressure test. Lines shall be filled slowly, with a maximum velocity of 1-foot per second, while venting all air. If permanent air vents have not been installed, the CONTRACTOR shall install corporation cocks at all high points to expel air during initial filling and testing of the lines.

Leakage is defined as the net quantity of water that must be supplied into the newly laid pipe, or any valved section thereof, necessary to return to the initial pressure of the specified leakage test pressure after the pipe has been filled with water and the air in the pipeline has been expelled. No pipe installation shall be accepted if the leakage is greater than that determined by the following formula:

$$L = (SD (P)^{1/2}) / 148,000 \text{ (See AWWA M23 Equation No. 5)}$$

Where,

L = allowable leakage in gallons per hour

S = length of pipe tested, in feet

D = nominal diameter of the pipe, inches

P = average test pressure during the leakage test, in pounds per square inch

The above equation is based on a leakage rate of 10.5 gallons per day per mile per inch of nominal diameter of pipe. Leakage values determined by the above formula for 1000 feet of pipe are presented in the table below. These values are similar to those presented in AWWA C605 and DIPRA (DIPRA, 2003).

ALLOWABLE LEAKAGE (gal/hr) FOR 1000 FT OF GASKETED PVC OR DIP PIPE

Nominal Average Test Pressure in Pipeline, psi

Pipe

Size (in)

	<u>50</u>	<u>75</u>	<u>100</u>	<u>125</u>	<u>150</u>	<u>175</u>	<u>200</u>
2	0.10	0.12	0.14	0.15	0.17	0.18	0.19
3	0.14	0.18	0.20	0.23	0.25	0.27	0.29
4	0.19	0.23	0.27	0.30	0.33	0.36	0.38
6	0.29	0.35	0.41	0.45	0.50	0.54	0.57
8	0.38	0.47	0.54	0.60	0.66	0.72	0.76
10	0.48	0.59	0.68	0.76	0.83	0.89	0.96
12	0.57	0.70	0.81	0.91	0.99	1.07	1.15
14	0.67	0.82	0.95	1.06	1.16	1.25	1.34
16	0.76	0.94	1.08	1.21	1.32	1.43	1.53
18	0.86	1.05	1.22	1.36	1.49	1.61	1.72
20	0.96	1.17	1.35	1.51	1.66	1.79	1.91
24	1.15	1.40	1.62	1.81	1.99	2.15	2.29
30	1.43	1.76	2.03	2.27	2.48	2.68	2.87
36	1.72	2.11	2.43	2.72	2.98	3.22	3.44
42	2.01	2.46	2.84	3.17	3.48	3.75	4.01
48	2.29	2.81	3.24	3.63	3.97	4.29	4.59
54	2.58	3.16	3.65	4.08	4.47	4.83	5.16
60	2.87	3.51	4.05	4.53	4.97	5.36	5.73
64	3.06	3.75	4.32	4.83	5.30	5.72	6.12

ALLOWABLE LEAKAGE (gal/hr) FOR 1000 FT OF GASKETED PVC OR DIP PIPE

Nominal Average Test Pressure in Pipeline, psi

Pipe

Size (in)

	<u>225</u>	<u>250</u>	<u>275</u>	<u>300</u>	<u>350</u>	<u>400</u>	<u>450</u>
2	0.20	0.21	0.22	0.23	0.25	0.27	0.29
3	0.30	0.32	0.34	0.35	0.38	0.41	0.43
4	0.41	0.43	0.45	0.47	0.51	0.54	0.57
6	0.61	0.64	0.67	0.70	0.76	0.81	0.86
8	0.81	0.85	0.90	0.94	1.01	1.08	1.15
10	1.01	1.07	1.12	1.17	1.26	1.35	1.43
12	1.22	1.28	1.34	1.40	1.52	1.62	1.72
14	1.42	1.50	1.57	1.64	1.77	1.89	2.01
16	1.62	1.71	1.79	1.87	2.02	2.16	2.29
18	1.82	1.92	2.02	2.11	2.28	2.43	2.58
20	2.03	2.14	2.24	2.34	2.53	2.70	2.87
24	2.43	2.56	2.69	2.81	3.03	3.24	3.44
30	3.04	3.21	3.36	3.51	3.79	4.05	4.30
36	3.65	3.85	4.03	4.21	4.55	4.86	5.16
42	4.26	4.49	4.71	4.92	5.31	5.68	6.02
48	4.86	5.13	5.38	5.62	6.07	6.49	6.88
54	5.47	5.77	6.05	6.32	6.83	7.30	7.74
60	6.08	6.41	6.72	7.02	7.58	8.11	8.60
64	6.49	6.84	7.17	7.49	8.09	8.65	9.17

Note: The allowable leakage for test sections with different diameters is the sum of the computed leakage for each pipe size.

The test pressure shall be applied by means of a pump connected to the pipe and to an approved water container, or other approved method, for accurate measurement. The test pressure shall be maintained (by additional pumping, if necessary) for the specified time. While the line is under pressure, the system and all exposed pipe, fittings, valves, and hydrants shall be carefully examined for leakage. All defective elements shall be repaired or replaced and the test repeated until all visible leakage has been stopped and the allowable leakage requirements have been met.

8. On completion of tests, any newly installed, approved taps shall be tightly plugged with brass fittings.
9. Thoroughly purge all compressed air lines after testing.

3.2 TEST PRESSURES FOR PRESSURE LINES

All pressure (force mains, plant water, and potable water) shall be tested to 1.5 times the working pressure or the rated pressure of the pipe, whichever is greater. Chemical piping shall be tested to 100 psig. Process, sludge, and drain piping using pressure pipe shall be tested at 75 psig if not specified elsewhere.

All potable, filtered, finished, and chemical pipe shall be disinfected in accordance with Section 01 09 01, DISINFECTION OF POTABLE WATER PIPING AND TANKS.

-- END OF SECTION --

SECTION 33 01 03 - DUCTILE IRON PIPE

PART 1 GENERAL

1.1 WORK INCLUDED

The work included in this section of the Specifications shall consist of furnishing, installing, and testing:

- A. Mechanical joint, push-on and flanged ductile iron pipe in sizes 4-inch through 48-inch.
- B. Mechanical joint and flanged ductile iron and cast iron fittings in sizes 4-inch through 60-inch.
- C. Gaskets and fasteners for above pipe and fittings.
- D. Restrained pipe and fittings, 4-inch thru 64-inch.
- E. Protective coatings, linings and encasements for above pipe and fittings.
- F. Hydrostatic testing, cleaning, and disinfecting of installed pipe and fittings.

1.2 REFERENCE STANDARDS

ASTM A307 - Standard Specification for Carbon Steel Bolts, Studs, and Threaded Rod 60 000 PSI Tensile Strength; 2014.

AWWA C104/A21.4 - Cement-Mortar Lining for Ductile-Iron Pipe and Fittings for Water; 2013.

AWWA C110/A21.10 - Ductile-Iron and Gray-Iron Fittings; 2012.

AWWA C111/A21.11 - Rubber-Gasket Joints for Ductile-Iron Pressure Pipe and Fittings; 2012.

AWWA C116/A21.16 - Protective Fusion-Bonded Coatings for the Interior and Exterior Surfaces of Ductile-Iron and Gray-Iron Fittings; Latest Edition.

AWWA C150/A21.50 - Thickness Design of Ductile-Iron Pipe; 2014.

AWWA C151/A21.51 - Ductile-Iron Pipe, Centrifugally Cast; 2009.

AWWA C153/A21.53 - Ductile-Iron Compact Fittings; 2011.

AWWA M41 - Ductile-Iron Pipe and Fittings; 2009.

NSF 61 - Drinking Water System Components - Health Effects; 2014 (Errata 2015).

1.3 QUALITY ASSURANCE

- A. All surfaces and materials in contact with water, or in contact with a chemical being added to water that is being treated for potable use, shall conform to NSF 61 and be certified by an organization accredited by ANSI, or shall meet the TCEQ requirements for contact with potable water.

1.4 DELIVERY, STORAGE AND HANDLING

Comply with the requirements of the Contract Documents, Specifications and the manufacturer's recommendations.

1.5 SUBMITTALS

Submit the following information in accordance with the requirements of the Contract Documents:

- A. Submit the following for all pipe systems:
 - 1. Pipe material
 - 2. Fittings
 - 3. Appurtenances
 - 4. Adaptors
 - 5. Pipe layout schedule/drawings including pipeline stationing and elevations with pressure classes, design and surge pressure ratings.
 - 6. All materials, coatings, and linings furnished.
 - 7. Thrust restraint design.

The pipe layout drawings and data shall clearly indicate where pipe requiring special provisions are provided.

- B. Certificate of Compliance with all applicable and appropriate reference standards certifying that all pipe, fittings, and specials, and other products and materials furnished, comply with the applicable provision of the Specification. Pipe systems submitted without the certificate of compliance may be returned without review.

- C. Certification of Adequacy of Design: The Certificate of Adequacy of Design shall show the necessary provisions required in the design of the pipe to comply with applicable sections of this Specification. The Certificate of Adequacy of Design shall be sealed by a Texas Registered Engineer.

PART 2 PRODUCTS

2.1 GENERAL

Ductile iron pipe shall be made of good quality ductile iron, tough, resilient, even-grained, and soft enough to satisfactorily permit drilling and cutting. All pipe shall be sound and free of cracks. Ductile iron pipe shall have a minimum tensile strength of 60,000 psi, a yield strength of 42,000 psi, and shall have a minimum working pressure rating of 150 psi, thickness Class 50. Ductile iron pipe shall be manufactured to the requirements of AWWA C150/A21.50 and AWWA C151/A21.51 standards.

The ductile iron pipe joint shall be rubber gasketed, push-on joint, similar to that known as Bell-Tite, Tite-On, Fastite, or equal, as may be approved by the ENGINEER; mechanical joint or flanged as called for on the Plans. The rubber gasket push-on joints and mechanical joints specified on the Plans shall be manufactured to the requirements of AWWA C151/A21.51 and AWWA C111/A21.11.

2.2 PUSH ON AND MECHANICAL JOINT PIPE AND FITTINGS

- A. Thickness Class: As required for working pressures and test pressures shown on the Plans for each pipe system.
- B. Laying Length: 18 or 20 feet.
- C. Gaskets: Neoprene, vulcanized styrene butadiene rubber (SBR) or equivalent material.

2.3 FLANGED PIPE AND FITTINGS

- A. All exposed ductile iron pipe shall have ductile iron flanged fittings unless otherwise noted. CONTRACTOR shall coordinate ductile iron flanges with connecting flanges of pump and valves. Thrust collars shall be provided where required for connection to restrained or harnessed flanged coupling adapters (FCA) and flexible couplings.
- B. Flanges: Thread pipe, tighten flanges, and face in shop equipped with machinery designed for such work. Hand or field work is not acceptable.
- C. Gaskets:
 - 1. Full face rubber 1/16-inch-thick factory cut unless otherwise specified. For ductile iron pipe and fittings between pump and steel discharge header gaskets shall be Toruseal by American or equal as approved by ENGINEER.
 - 2. For air systems only, full-face Buna-N gaskets, 1/16-inch thick factory cut. Gaskets shall be suitable for temperatures of 200 F with lubrication oil present.
- D. Bolts and Nuts:
 - 1. Type: Hex heads and nuts.
 - 2. Material: Low carbon steel conforming to ASTM A307 Grade B except for submerged and buried locations.
 - 3. Submerged bolts and nuts shall be 316 stainless steel.
 - 4. Bolts and nuts in buried locations or in manholes shall be 304 stainless steel.
- E. Thickness Class: As noted on Plans. Use Class 150 if not shown on Plans.

2.4 FITTINGS

- A. Fittings shall be ductile iron castings, all conforming to AWWA C110/A21.10 or AWWA C153/A21.53. Flanged ends shall be made of ductile iron, and shall have comparable pressure rating to pipe.
- B. Coatings shall be as specified for ductile iron pipe.
- C. All buried fittings shall be wrapped with a polyethylene wrapping.
- D. All fasteners, bolts, and hardware that are buried or in manholes shall be 304 stainless steel. Buried MJ fitting bolts may be Corten.

2.5 PROTECTIVE COATINGS, LININGS, AND ENCASEMENT

- A. Inside of Pipe:
 - 1. Unless otherwise shown, all ductile iron shall be provided with a cement-mortar lining in accordance with AWWA C104/A21.4. A bituminous seal coat shall be applied over the mortar lining in accordance with AWWA C104/A21.4.
 - 2. Inside of Pipe: Where specifically shown or specified, epoxy lining shall be provided. Epoxy lining shall be high solids, high build fusion bonded epoxy per AWWA C116/A21.16 suitable for use in potable water, minimum 16 mils dft.
- B. Outside of Pipe:
 - 1. For exposed piping including piping in vaults provide one shop coat of primer and field paint with one coat of primer and one finish coat in accordance with Section 09 03 01, COATING & PAINTING FOR WATER TREATMENT PLANTS.
 - 2. For buried piping, provide bituminous coating.
- C. Provide Polyethylene Encasement for all buried piping and fittings except for concrete encased pipe and fittings and pipes in tunnels or bores.

2.6 INSULATED CONNECTIONS

The pipe vendor shall furnish dielectric insulation gaskets and/or bushings at all places where steel pipe or valves connect to ductile and cast iron pipe and fittings. Where flanges are to be insulated, furnish and install a complete flange isolation kit including a flange gasket, isolating sleeve for each bolt, and two isolating washers for each bolt. Flange isolation kits shall be Saint Ferrer Model #105-EK2 by Westermann, or approved equal.

2.7 RESTRAINED PIPE AND FITTING JOINTS

Restrained pipe and fitting joints shall utilize push on type joint fittings with ductile iron components as fabricated by U.S. Pipe - TR FLEX or approved equivalent. Field cut pipe shall be provided with U.S. Pipe - TR FLEX gripper ring or approved equivalent sized for working pressures shown on plans (150 psi minimum) for sizes through 36-inch. At CONTRACTOR's option, restrained buried fittings and pipes with working pressures at or below 100 psi may utilize mechanical joints with EBAA iron Megalug type joint restraint with Corten bolts. Pipe and fittings that are concrete encased do not require mechanical restraint.

PART 3 EXECUTION

3.1 INSTALLATION

- A. General:
 - 1. Use the types of pipe and joints specified and shown on the Plans.
 - 2. Follow the manufacturer's installation instructions.
 - 3. Wrap all buried piping and fittings with polyethylene.
 - 4. Pipe shall be installed on constant grade between control depths as shown on the Plans, with minimum depth of cover maintained.
 - 5. Utilize [Class III] embedment if not shown on Plans.
 - 6. Provide a restrained push-on joint or MJ joint 10 feet outside of structures. Alternatively, provide a restrained coupling 10 feet outside of structures.
- B. Flexible Couplings and Flanged Coupling Adaptors:
 - 1. Install in accordance with the Plans, specifications for couplings and adaptors, and approved shop drawings.
 - 2. Use of additional couplings and adaptors to be approved by OWNER prior to installation.
 - 3. All flexible couplings and flanged coupling adaptors shall be restrained.
- C. Joining of Push-on Piping:
 - 1. Preparation of pipe ends: Remove from bell and spigot ends all lumps, blisters, excess coal-tar coating, oil and grease, then wire brush and wipe clean and dry before laying pipe.
 - 2. Installation of ring gasket:
 - a. Wipe gasket seat in socket with clean dry cloth.
 - b. Place gasket with large end entering first.

- c. Spring gasket into seat in bell so that groove fits overhead in seat.
 - d. Apply thin film of food grade lubricant to inside surface of gasket.
 - 3. Setting spigot:
 - a. Apply food grade lubricant to engaging surface of spigot if necessary.
 - b. Align spigot with bell and start into bell so that it contacts gasket.
 - c. Pipe 6 inches and smaller may be driven with a bar lever on end of pipe.
 - d. For larger pipe, use only approved ratchet-type jacking tool to pull pipe "home."
- D. Joining of Mechanical Joint Pipe:
 - 1. Remove all mud and foreign matter from pipe ends, gaskets and fittings before installation.
 - 2. Wash pipe ends, gaskets and fittings with soapy water before installation.
 - 3. Mechanical joints must be suitably restrained to prevent movement.
- E. Joining of Flanged Pipe:
 - 1. Setting gasket:
 - a. If non-graphited gaskets are used, apply graphite and water solution to gasket before placing on flange.
 - b. Wire-brush flange and clean inside of pipe before placing gasket.
 - 2. Tightening bolts:
 - a. After initial alignment, place flange bolts with all heads in same direction.
 - b. Tighten flange bolts, each in turn, at uniform rate around joint until all are tightened to the manufacturer's recommended torque.
 - 3. All flanged coupling adaptors must be restrained.
- F. Restrained Joints
Install restrained joints in strict accordance to manufacturer's recommendations. Thrust restraint design shall be performed by a Texas Licensed Professional Engineer. The CONTRACTOR shall furnish restraint length calculations for ductile iron pipe in accordance with AWWA M41 based pressures and depth of cover shown in the Plans . Pressure utilized shall be working pressures shown and/or specified, plus an additional 350 psig for surge for potable water and service water piping, and high service pump discharge piping. Use test pressure times 1.5 for all other pipelines.

-- END OF SECTION --

SECTION 33 01 06 - POLYVINYL CHLORIDE (PVC) PRESSURE PIPE

PART 1 GENERAL

1.1 WORK INCLUDED

Furnishing, installing (by General CONTRACTOR), and testing (by General CONTRACTOR) of polyvinyl chloride (PVC) pressure pipe and fittings in sizes 1/2-inch through 36-inch. Hydrostatic testing, cleaning, and disinfecting installed pipe and fittings.

1.2 REFERENCE STANDARDS

ASME B16.5 - Pipe Flanges and Flanged Fittings NPS 1/2 Through NPS 24 Metric/Inch Standard; 2013.

ASTM D1784 - Standard Specification for Rigid Poly(Vinyl Chloride) (PVC) Compounds and Chlorinated Poly(Vinyl Chloride) (CPVC) Compounds; 2011.

ASTM D1785 - Standard Specification for Poly(Vinyl Chloride) (PVC) Plastic Pipe, Schedules 40, 80, and 120; 2015.

ASTM D2241 - Standard Specification for Poly (Vinyl Chloride) (PVC) Pressure-Rated Pipe (SDR Series); 2015.

ASTM D2464 - Standard Specification for Threaded Poly(Vinyl Chloride) (PVC) Plastic Pipe Fittings, Schedule 80; 2015.

ASTM D2466 - Standard Specification for Poly(Vinyl Chloride) (PVC) Plastic Pipe Fittings, Schedule 40; 2015.

ASTM D2467 - Standard Specification for Poly(Vinyl Chloride) (PVC) Plastic Pipe Fittings, Schedule 80; 2015.

ASTM D2564 - Standard Specification for Solvent Cements for Poly(Vinyl Chloride) (PVC) Plastic Piping Systems; 2012.

ASTM D2855 - Standard Practice for the Two-Step (Primer & Solvent Cement) Method of Joining Poly (Vinyl Chloride) (PVC) or Chlorinated Poly (Vinyl Chloride) (CPVC) Pipe and Piping Components with Tapered Sockets; 2015.

ASTM D3139 - Standard Specification for Joints for Plastic Pressure Pipes using Flexible Elastomeric Seals; 1998 (Reapproved 2011).

ASTM F477 - Standard Specification for Elastomeric Seals (Gaskets) for Joining Plastic Pipe; 2014.

ASTM F493 - Standard Specification for Solvent Cements for Chlorinated Poly (Vinyl Chloride) (CPVC) Plastic Pipe and Fittings; 2014.

AWWA C900 - Polyvinyl Chloride (PVC) Pressure Pipe, 4 In. Through 12 In. (100 mm Through 300 mm), for Water Transmission and Distribution; 2016.

AWWA C905 - Polyvinyl Chloride (PVC) Pressure Pipe and Fabricated Fittings, 14 In. Through 48 In. (350 mm Through 1,200 mm), for Water Transmission and Distribution; Latest Edition.

NSF 61 - Drinking Water System Components - Health Effects; 2014 (Errata 2015).

1.3 SUBMITTALS

- A. Submit shop drawings and product data in accordance with the requirements of Sections 01 04 01, SUBMITTALS and 33 01 01, GENERAL REQUIREMENTS FOR PIPING SYSTEMS.
- B. Submit manufacturer's installation instructions.
- C. Submit affidavits of compliance with the referenced standards. Pipe systems submitted upon without the affidavits of compliance shall be returned without review.

1.4 DELIVERY, STORAGE AND HANDLING

- A. Comply with the general requirements of Section 33 01 01, GENERAL REQUIREMENTS FOR PIPING SYSTEMS and the supplemental requirements below.
- B. Comply with the manufacturer's handling and storage recommendations.
- C. Use nylon slings or rope to lift bundles of pipe. Do not use chains.
- D. Do not drop pipe.
- E. Support pipe every 4 feet.
- F. Limit stacking height of pallets to prevent any undue stress or deflection in pipe materials.

PART 2 PRODUCTS

2.1 GENERAL

- A. Pressure pipe for potable water systems shall bear the seal of approval of the National Sanitation Foundation for use in potable water systems.
- B. All PVC pipe shall be new and shall be stamped to show the design working pressure.
- C. Pressure pipe shall be as manufactured by Can-Tex Industries, Certain-Teed Pipe Company, Johns-Manville or approved equal.
- D. The pipe shall have true section complying with the sizes specified. All pipe shall be free from cracks, holes, blisters, voids, projections, defects, roughness and chalking, sticky or tacky material.
- E. All pipe and fittings furnished under this section shall be clearly marked by the manufacturer with the following information in such a manner that it will remain legible after inspection:
 - 1. Manufacturer's name, trademark and code which includes the date, shift, plant and extruder of manufacturer.
 - 2. Nominal pipe size in inches.
 - 3. PVC cell classification.
 - 4. AWWA/ASTM designation.

2.2 EXPOSED PIPING

- A. Pipe:
 - 1. Referenced Standard: ASTM D1785.
 - 2. Type: Type 1, Grade 1, unplasticized.
 - 3. Schedule: Schedule 80 is required, unless otherwise shown on Drawings or specified in Piping Schedule.
- B. Joints:
 - 1. Type: Solvent welded unless otherwise shown on Drawings or specified in Piping Schedule.
 - 2. Referenced Standard for Cement ASTM D2564.
- C. Fittings:
 - 1. Referenced Standards: ASTM D2464, ASTM D2466 and ASTM D2467.
 - 2. Type: Solvent weld unless otherwise shown on Drawings or specified in Piping Schedule.

2.3 BURIED PRESSURE PIPING

- A. Sized Under 1-1/2 Inches:
As specified above for exposed piping.
- B. Sizes Through 4 Inches:
 - 1. Pipe:
 - a. Referenced Standard: ASTM D1785 and ASTM D2241.
 - b. Type: Type 1, Grade 1, unplasticized.
 - c. Schedule as shown on the Plans.
 - 2. Joints:
 - a. Referenced Standard: ASTM D3139.
 - b. Gasket Type: ASTM F477.
 - 3. Fittings:
 - a. Referenced Standard: ASTM D2466.
 - b. Type: Solvent weld unless otherwise shown on drawings or specified in piping schedule.
- C. Sizes 4 Inches Through 12 Inches:
 - 1. Pipe:
 - a. Referenced Standards: AWWA C900.
 - b. Type: Bell and spigot with elastomeric gasket joint formed integral with Pipe.
 - c. Pressure Class and Dimension Ratio: 150 psig; D.R. 18 if not shown on Plans.

2. Joints:
 - a. Referenced Standard: ASTM D3139.
 - b. Gasket Type: ASTM F477.
 3. Fittings:
 - a. Type: Mechanical joint or push-on type, ductile iron fittings.
 - b. Fittings shall utilize mechanical joint restraint systems designed by Supplier. If not shown, utilize 150 psig test pressure and 7 fps velocity for surge calculation.
 - c. Bolts, fasteners, and hardware for buried fittings shall be 304 stainless steel. Buried MJ fitting bolts may be Corten. Submerged bolts, fasteners, and hardware shall be 316 stainless steel.
- D. Sizes 14 Inches Through 36 Inches:
1. Pipe:
 - a. Referenced Standards: AWWA C905.
 - b. Type: Bell and spigot with elastomeric gasket joints formed integral with pipe.
 - c. Pressure Class and Dimension Ratio: 235 psig; D.R. 18 if not shown on Plans.
 2. Joints:
 - a. Referenced Standard: ASTM D3139.
 - b. Gasket Type: ASTM F477.
 3. Fittings:
 - a. Type: Mechanical joint or push-on type, or ductile iron fittings.
 - b. Fittings shall utilize mechanical joint restraint systems designed by Supplier. If not shown, utilize 150 psig test pressure and 7 fps velocity for surge calculation.
 - c. Bolts, fasteners, and hardware for buried fittings shall be 304 stainless steel. Buried MJ fitting bolts may be Corten. Submerged bolts, fasteners, and hardware shall be 316 stainless steel.

2.4 CHEMICAL PIPING

- A. PVC Piping: PVC pipe for chemicals, vacuum and solution, shall be ASTM D1785, Type 1, Grade 1, Schedule 80 for exposed piping and Schedule 40 for buried piping, rigid, unplasticized PVC, normal impact, bearing NSF seal. Fittings shall be molded, bearing NSF seal, as manufactured by Tube Turn Plastics, or equal. Pipe threads, if used, shall conform to ASA 82.1, NPT, and shall be full and cleanly cut with sharp dies.
1. If glued joints are used, cement shall be of type which welds plastic surfaces together. Cement shall be as recommended by the pipe manufacturer and shall be compatible with the chemical conveyed. Teflon tape shall be used on all threaded joints. Teflon tape shall be mil spec P-77304 or as recommended by the pipe supplier for the chemical service. Tubing connecting to piping shall utilize barbed fittings and 316 stainless steel tube clamps, two per connection. Barbed fittings shall be CPVC or other material recommended by the manufacturer rated for working pressure of 50 psig and chemical service up to 110 Degrees F.
 2. Gaskets and O-rings for chlorine vacuum and solution piping shall be Viton. Gaskets and O-rings for other chemicals shall be compatible with the chemical being used.
 3. Cement and primers shall be suitable for use in potable water. Cement shall be industrial grade and primer shall be purple color. Cement used shall have a manufacture date within 14 months of the date being utilized. Containers shall be kept tightly closed when not in use. Brush or swab applicators shall be appropriately sized and utilized as recommended by the manufacturer.
 4. Chemical piping shall be tested to a hydrostatic pressure of 150 psig in accordance with Section 33 01 02, FIELD TESTING OF PIPING SYSTEMS.
 5. Mark pipe in accordance with ASTM D1785.

PART 3 EXECUTION

3.1 INSTALLATION

- A. General:

1. Comply with the general requirements of Sections 33 01 01, GENERAL REQUIREMENTS FOR PIPING SYSTEMS and the supplemental requirements following.
 2. Install all piping in accordance with pipe manufacturer's instructions.
 3. Chemical piping shall be installed at uniform grades or slopes without any high points in the pipe except at the pumps.
- B. Making of Joints:
1. General:
 - a. Make joints in accordance with pipe manufacturers recommendations and the supplemental specifications below.
 - b. For shorter than standard pipe lengths, field cuts may be made with either hand or mechanical saws with fine tooth blade (16-18 teeth per inch) or plastic pipe cutters. Cut piping accurately and squarely within 1/8 inch and install without forcing or springing.
 - c. Ream out all pipes and tubing to full inside diameter after cutting.
 - d. Remove all cuttings and foreign matter from the inside of pipes and ends shall be smoothly beveled by a mechanical beveller or by hand with a rasp or file before installation. Field spigots shall be stop-marked with an adequate marker for the proper length of assembly insertion.
 - e. Joints shall not be covered until approved by ENGINEER or his representative. Connections which are made for future use shall be properly capped.
 2. Solvent Weld Joints Only:
 - a. Comply with the requirements of ASTM D2855 and ASTM F493.
 - b. File end of PVC Pipe to form a 10 to 15 degree bevel 1/16-inch to 3/32-inch wide on the exterior of the pipe end.
 - c. The pipe and fittings shall be cleaned of all loose dirt and moisture and then lightly roughened with emery cloth over the entire surfaces to be glued, after cutting pipe and removing all burrs and prior to applying the primer.
 - d. Apply primer to the female end, then the male end and then reapply to female end, keeping the surface wet with primer over 5- to 15-second period.
 - e. Apply solvent cement to pipe end and socket and then apply a second coat to pipe end using a brush one-half of the diameter of the pipe. Hold for 30 seconds.
 - f. Immediately insert pipe end in socket and wipe off excess cement.
 - g. Rotate pipe under 6 inches about one-quarter turn after inserting in socket.
 - h. Completed glue joints shall not have any gaps or voids in the glue between the pipe and the fitting.
 - i. Do not perform solvent welding operations when temperature is below 40 Degrees F or above 90 Degrees F, or when rain or drizzle is present.
 - j. Do not move or disturb the glued joints for 3 minutes after completion. Joints shall not have any pressure or deflection applied for at least 1 hour after completing the joint. Allow all joints to set 24 hours prior to performing pressure test on system.
 - k. All joints shall be checked for leakage 48 hours and again 15 days after placing them in service with the proposed chemical. Joints which show signs of leaking or signs of salt buildup shall be replaced and system retested and checked again 48 hours and 15 days after repair until satisfactory results are obtained.
 - l. Small diameter pipes shall be checked for excess glue after the joints have set. Joints with more than one-half of the pipe area blocked shall be drilled or reamed out.
 - m. All pipe systems shall be flushed at velocity greater than 5 fps for a minimum of 5 minutes and longer for pipes larger than 300 feet.
 3. Threaded Joints Only:
 - a. Use liquid lubricant for permanent joints.
 - b. Use tape lubricant at valves and equipment where piping may have to be disconnected for maintenance.
 4. Gasketed Joints Only:

- a. Thoroughly clean pipe ends and gaskets before installation.
 - b. Apply lubricant recommended by manufacturer.
- 5. Plastic to Metal Connections:
 - a. Make all plastic to metal connections by means of PVC adapters.
 - b. Do not cut threads on PVC Pipe.
- C. Buried Piping:
 - 1. All excavation shall be done in an approved manner to the elevations and grades shown on the Plans or specified. The trench bottom shall be free of sharp rocks and large clods of dirt.
 - 2. Bedding for PVC pipe (larger than 2-inch) shall be as shown on the Plans: Utilize Class 2 embedment if not called out on the Plans.
 - 3. Backfill shall be placed according to Section 31 03 01, TRENCHING, BACKFILLING AND COMPACTING.
 - 4. Sand or granular embedment material shall be used for PVC pipe 2 inches and smaller.
- D. Exposed Piping:
 - 1. Where required, PVC piping shall be installed in the locations indicated with hangers, brackets, supports, etc., at spacings specified in Section 33 01 01, GENERAL REQUIREMENTS FOR PIPING SYSTEMS and recommended by the pipe manufacturer.
 - 2. Flexible connections shall be required at locations where pipe passes through a concrete wall.
- E. Restrained Joints
All buried pressure pipe systems utilizing mechanical joints shall be restrained as specified in Section 33 01 01, GENERAL REQUIREMENTS FOR PIPING SYSTEMS.

3.2 FIELD TESTING

Comply with the requirements of Section 33 01 02.

-- END OF SECTION --

SECTION 33 01 08 - PIPE COUPLINGS AND EXPANSION JOINTS

PART 1 GENERAL

1.1 WORK INCLUDED

Flexible couplings, flange coupling adapters, expansion joints, and restraining hardware for above items.

1.2 REFERENCE STANDARDS

ASTM A183 - Standard Specification for Carbon Steel Track Bolts and Nuts; 2014.

ASTM A536 - Standard Specification for Ductile Iron Castings; 1984 (Reapproved 2014).

AWWA C606 - Grooved and Shouldered Joints; 2015.

NSF 61 - Drinking Water System Components - Health Effects; 2014 (Errata 2015).

1.3 QUALITY ASSURANCE

A. Factory Assurance:

1. Test each item for mechanical and material defects per manufacturer's standard practice.
2. Hydrostatically test each item to 150 percent of its maximum allowable working pressure.

B. All surfaces and materials in contact with water, or in contact with a chemical being added to water that is being treated for potable use, shall conform to NSF 61 and be certified by an organization accredited by ANSI, or shall meet the TCEQ requirements for contact with potable water.

1.4 SUBMITTALS

A. Shop Drawings, Product Data and Samples:

Comply with the general requirements of Section 01 04 01, SUBMITTALS and supplemental requirements below.

B. Submit the following items for each type flexible coupling, flanged coupling adaptor, and rubber expansion joint.

1. Description and illustration of construction.
2. List of materials.
3. Description of factory-applied protective coatings.
4. Dimensions.
5. Pressure rating.
6. For expansion joints only, the movement, force, and spring rate capabilities.
7. Shop drawings for restraining systems such as tie bolt assemblies. Drawings to show layout, dimensions, number and size of bolts, and lug details.
8. Manufacturer's installation instructions.

C. Product data described in the previous paragraph may be submitted in the form of catalog bulletins or other standard manufacturer literature and drawings as long as all the data specified are furnished. If catalog bulletins are submitted, they are to be marked up to show the styles, options, and other data which are applicable.

D. If CONTRACTOR elects to use more couplings and expansion joints than are shown on Drawings, submit piping layout drawings showing the location of each proposed additional unit and describing the type of each such unit.

1.5 PRODUCT DELIVERY, STORAGE AND HANDLING

Comply with the requirements of Section 33 01 01, GENERAL REQUIREMENTS FOR PIPING SYSTEMS.

PART 2 PRODUCTS

2.1 FLEXIBLE COUPLINGS

A. Flexible couplings to be mechanical compression type with sleeve two follower glands, two resilient wedge-shaped gaskets, and a set of bolts and nuts to draw the two follower glands together.

B. Construction of Coupling:

1. Middle ring: Carbon steel.
 2. Followers: Carbon steel except that ductile or malleable iron may be used in sizes 12 inches and smaller.
 3. Gaskets:
 - a. Resilient rubber compound suitable for air, water, and sewage service and temperatures below 15° F. Buna-N for 240° F for air service.
 - b. Wedge shaped.
 4. Bolts and nuts:
 - a. Cadmium-plated high strength steel for exposed couplings in noncorrosive environments.
 - b. Number and size as required for size and type coupling and as recommended by manufacturer for test pressure.
 - c. Buried couplings or couplings in manholes shall utilize 304 SS bolts and hardware.
 - d. Submerged couplings shall utilize 316 SS bolts and hardware.
- C. Restraining System:
1. To be used for all flexible couplings unless specifically noted otherwise.
 2. Description:
 - a. Restraining system or harness to consist of tie bolts anchored on each side of coupling to prevent separation of pipe and coupling due to pressure or other causes.
 - b. Tie bolts to be anchored to lugs bolted to nearest flange each side of coupling. On steel pipe, tie bolts may be anchored to lugs shop welded to pipe.
 - c. Number and size of tie bolts to be as determined by manufacturer for specified piping system test pressure. A minimum of two tie bolts diametrically opposite one another are required for each restrained coupling.
 3. Tie bolts and nuts: As specified above for flexible coupling.
- D. Factory Painting:
1. Apply epoxy-type protective coating system to interior suitable for potable water contact, and exterior of couplings. Coating to be manufacturer's standard epoxy system complete with prime and finish coats.
 2. Do not paint bolts, nuts, and gaskets.
 3. Coatings used on exterior of couplings which will be exposed to be compatible with specified coating system for piping so that pipe and couplings can be painted a common color. Coating for buried couplings shall be epoxy.
 4. Coatings on air pipe systems shall be suitable for 240° F.
- E. Manufacturer and Model:
1. Dresser Industries, Inc. - Dresser Style 38.
 2. Smith Blair - Type 411.
 3. Or approved equivalent.

PART 3 EXECUTION

3.1 INSTALLATION

- A. General:
1. Inspect each coupling, adaptor, and expansion joint for damage and defects before installation and replace defective items.
 2. Install each item in accordance with the Drawings, TECHNICAL SPECIFICATIONS, approved piping layout shop drawings, and approved manufacturer's installation instructions.
 3. CONTRACTOR may provide additional flexible couplings, flanged coupling adapters, and expansion joints over and above those shown on Drawings to facilitate installation of piping.
 - a. Use of such additional items is to be approved by the ENGINEER prior to installation.
 - b. Additional joints are to be at no expense to the OWNER.

4. Verify that inside diameters of flexible couplings and flanged coupling adapters are compatible with outside diameters of piping with which couplings or adapters are being used.
- B. Flexible Couplings:
1. Clean and lubricate pipe ends before installation.
 2. Leave a gap between the pipe ends to permit pipe expansion and increase flexibility of the joint. Gaps between pipe ends to be approximately as follows:
 - a. 12-inch diameter and smaller: +/- 1 inch.
 - b. 24-inch diameter through 36-inch: +/- 1 1/2 inch.
 - c. Over 36 inches: 2 inch.
 3. Tighten bolts in manner and to torques prescribed by manufacturer.
- C. Expansion and Vibration Control Joints:
1. Prevent equipment vibration transmitted through piping system, and prevent damaging stresses due to normal expansion and contraction with temperature changes in piping and connected equipment.
 - a. Where anticipated expansion is greater than can be absorbed by the normal piping configuration, install loops, bends, and expansion joints as indicated on the drawings, to absorb excess expansion.
 2. Install expansion joints so as to allow 2 1/4-inch expansion per 100 linear feet of piping.
 3. Where possible, install expansion joints adjacent to an anchor, and provide one concentric guide on piping within 12 pipe diameters, but not more than 5 feet, from the end of the joint opposite the anchor. Locate a similar guide approximately 30 diameters but not more than 10 feet from the first.
 4. For expansion joints not installed adjacent to an anchor, provide two concentric guides similarly located at each end of the joint.
 5. Provide control rods and additional guides where indicated on the Drawings, but at no greater intervals than recommended by the joint manufacturer in published instructions.
 6. Space intermediate supports a minimum of 10 feet, and tack weld the protective saddles to the pipe.
- D. Field Painting:
1. Touch up factory finishes which have been damaged.
 2. Apply protective coating to bolts and nuts after tightening. Use same coating system as that specified for adjoining piping.
- E. Testing:
1. Joints are tested as a part of the overall piping system.
 2. See Section 33 02 01, FIELD TESTING OF PIPING SYSTEMS.

-- END OF SECTION --

SECTION 33 02 04 - GATE VALVES

PART 1 GENERAL

1.1 REFERENCE STANDARDS

- AWWA C105/A21.5 - Polyethylene Encasement for Ductile-Iron Pipe Systems; 2010.
- AWWA C500 - Metal-Seated Gate Valves for Water Supply Service; 2009.
- AWWA C509 - Resilient-Seated Gate Valves for Water Supply Service; 2009.
- AWWA C550 - Protective Interior Coatings for Valves and Hydrants; 2013.
- NSF 61 - Drinking Water System Components - Health Effects; 2014 (Errata 2015).

1.2 WORK INCLUDED

The CONTRACTOR shall furnish and install resilient-seated vertical gate valves, and appurtenances, including valve boxes, operators, bolts, nuts and gaskets completely as specified herein.

1.3 QUALITY ASSURANCE

- A. All gate valves shall be manufactured and tested to meet the requirements of AWWA C509 unless otherwise specified.
- B. Body thickness and stem thickness will conform to AWWA C500.
- C. Each valve shall have manufacturer's name plate in stainless steel or cast into body or bonnet showing the pressure ratings, serial and model numbers, year manufactured and other pertinent data.
- D. Manufacturers of gate valves shall demonstrate a minimum of 5 years experience for the design of gate valves, with at least 1-year experience in the design of resilient seated gate valves (AWWA C509) being furnished. References shall be furnished upon request.
- E. Valve supplier shall maintain a complete stock of spare parts in the State of Texas and shall be capable of delivering parts within 48 hours of receipt of request.
- F. All surfaces and materials in contact with water, or in contact with a chemical being added to water that is being treated for potable use, shall conform to NSF 61 and be certified by an organization accredited by ANSI, or shall meet the TCEQ requirements for contact with potable water.

1.4 SUBMITTALS

- A. Shop Drawings and Product Data:
 - 1. Comply with the general requirements of Section 01 04 01, SUBMITTALS, and the supplemental requirements below.
 - 2. Submit one drawing or illustration showing unit construction for each type and size valve used.
 - 3. Submit the following information for each valve:
 - a. Description including type of valve, type of operator and accessories included.
 - b. Size and end connections.
 - c. Maximum non-shock working pressure for which valve is designed.
 - d. Materials of construction and coatings for valves, operators and accessories.
 - e. K or Cv value.
 - f. Manufacturer's make and model.
 - 4. Submit the following information for geared operators:
 - a. Type of gearing.
 - b. Type of lubrication.
 - c. Size of handwheel, lever or crank.
 - d. Input torque required to develop required output torque.
 - e. Orientation and dimensions of operator.
 - f. Manufacturer's make and model.
 - 5. If catalog bulletins are used to communicate above information, mark out inapplicable information.

- 6. Location of nearest stocking distributor.
- B. Affidavits:
 - 1. Submit affidavits of compliance with the reference standards.
- C. Operation and Maintenance Data:
 - 1. Comply with the requirements of Section 01 04 01, SUBMITTALS.
- D. Special Equipment Warranty as in the Special Conditions.
- E. Installation reports as specified in Section 01 04 01, SUBMITTALS.
- F. Valve manufacturer shall provide certification from an independent testing laboratory that its valve can operate through 1000 cycles at unbalanced closing pressure (working pressure) and flow to open discharge without causing damage to any of the epoxy coating on the body or rubber coating on the gate.

1.5 DELIVERY, STORAGE AND HANDLING

Comply with the requirements of the Section 33 01 01, GENERAL REQUIREMENTS FOR PIPING SYSTEMS and manufacturer's recommendations.

PART 2 PRODUCTS

2.1 GENERAL

- A. Obtain all gate valves, extensions, and associated manual operators from a single manufacturer.
- B. Valve operators to turn to left, counter clockwise, to open and to right, clockwise, to close.
- C. End connections on valves to be as shown on the Drawings.
- D. All flanges shall conform to the standard specification of the American National Standards Institute (ANSI), Class 125 unless otherwise noted.
- E. Valve body and bonnet shall be coated on all exterior and interior surfaces with a fusion-bonded epoxy conforming to the requirements of AWWA C550.
- F. Furnish geared operators for all valves 12 inches and larger, unless otherwise specified.
- G. Furnish geared operators with the following features unless otherwise specified.
 - 1. Weatherproof enclosure.
 - 2. Grease lubricated design.
 - 3. Operate with an input force of not more than 80 pounds pull.
- H. Buried valves shall utilize solid 316 stainless steel shaft extensions with 2-inch square nut within 18 inches of grade and valve boxes with covers.
- I. Exposed valves shall utilize handwheel or chainwheel operators unless otherwise noted.
- J. Valves in buried and submerged service shall utilize 304 stainless steel hardware and bolts. Buried MJ fitting bolts may be Corten.

2.2 RESILIENT-SEATED GATE VALVE DETAILS

- A. Provide valves as shown on the Plans.
- B. Install in vertical position only.
- C. Non-shock working pressure: 200 psig through 12 inches, 150 psig larger than 12 inches.
- D. Valve body: Ductile iron with full round port opening and integrally cast guides; smooth valve bottom with no recessed areas; bonnet cover.
- E. Gate shall be completely covered with rubber on all interior and exterior ferrous surfaces. The rubber shall be secured to the gate body, including the part which houses the stem nut.
- F. Stem: Valve stem shall be cast, forged, or rolled bronze.
- G. Stem seals: Double O-ring, Buna-N protected by grit and dust cap.
- H. Stem nut: Brass or bronze.
- I. Nylon bushing and Teflon washer for friction protection.
- J. Interior coating: 2-part epoxy coating or approved equal.
- K. Acceptable Manufacturers:
 - 1. M&H
 - 2. Mueller

2.3 ACCESSORIES

- A. Valve boxes for buried service:
 - 1. Three piece screw type 5-1/2-inch diameter, cast iron construction.
 - 2. 6 inch PVC pipe with cast iron cover marked "Water", cast iron mushroom insert with top 12" above ground unless directed otherwise.
- B. All components of shaft extensions shall be 316 stainless steel including nut shaft, shaft housing and guides. Minimum shaft diameter shall be 1-inch or diameter of valve shaft, whichever is larger. All components shall have continuous welded joints. Provide stem guides or rock shields at 5-foot intervals.
- C. Acceptable Manufacturers:
 - 1. Three piece screw type valve boxes for buried service: East Jordon Iron Works, Model 8560
 - 2. Or approved equivalent.

PART 3 EXECUTION

3.1 INSTALLATION

- A. The Construction CONTRACTOR shall install the valves in accordance with the following requirements:
 - 1. Installation shall be in accordance with the Plans, approved shop drawings and the manufacturers instructions.
 - 2. Install valves and valve operators to provide for ease of access and operation.
 - 3. Install buried valve by carefully lowering into position in such a manner to prevent damage to any part of the valves. The valve shall be placed in proper position and shall be securely held until all connections have been made. All buried pipe and appurtenances shall be wrapped in polyethylene encasement in accordance with AWWA C105/A21.5.
- B. The Equipment Manufacturer shall furnish all accessories and hardware necessary for installation.

3.2 FIELD QUALITY CONTROL

- A. The Equipment Manufacturer shall perform the following services:
 - 1. Inspect the completed installation and note deficiencies.
 - 2. Assist the CONTRACTOR during start-up, adjusting, and site testing of completed installation as required.
 - 3. Instruct OWNER personnel in the operations and maintenance of the equipment.
- B. TESTING: Testing will be in accordance with Sections 33 01 02, FIELD TESTING OF PIPING SYSTEMS. All valves shall be tested by manufacturer in accordance with AWWA C500.
- C. All valves shall be operated over the full range of travel without excessive force for at least two complete cycles; open-closed-open-closed. Valve shall not hang and shall seat and unseat to/from fully closed position. Testing shall be done after actuators and stem extensions are installed. Verify valve tag is installed and correct. Verify valve position indicator correctly reflects valve positions and limit switches (if used) are set correctly. Valves with motor or pneumatic actuators shall be operated with handwheel as well as automatic actuator.

-- END OF SECTION --

SECTION 33 05 01 - BORE AND ENCASEMENT

PART 1 GENERAL

1.1 WORK INCLUDED

- A. The work under this Section consists of furnishing all materials, labor, equipment, and services required for the complete installation of encasement pipe and carrier pipes under highways, railroads and creeks/ivers by boring, jacking, or directional boring as shown on the Drawings and specified herein.
- B. All work in connection with constructing encasement pipes under highways and railroads shall comply with all current requirements of governing highway and railroad agencies. The CONTRACTOR shall be familiar with these requirements.
- C. The CONTRACTOR shall inspect the locations at the proposed crossings and shall familiarize himself with the conditions under which the work will be performed, and with all necessary details and the suitability of his equipment and methods for the work required.

1.2 REFERENCE STANDARDS

ASTM A139/A139M - Standard Specification for Electric-Fusion (Arc)-Welded Steel Pipe (NPS 4 and Over); 2016.

ASTM C150/C150M - Standard Specification for Portland Cement; 2016.

ASTM C33/C33M - Standard Specification for Concrete Aggregates; 2016.

ASTM C618 - Standard Specification for Coal Fly Ash and Raw or Calcined Natural Pozzolan for Use in Concrete; 2015.

ASTM D4832 - Standard Test Method for Preparation and Testing of Controlled Low Strength Material (CLSM) Test Cylinders; Latest Edition.

1.3 DEFINITIONS

- A. Auger Boring: A technique for forming a bore from a drive pit to a reception pit, by means of a rotating cutting head. Spoil is removed back to the drive pit by helically wound auger flights rotating in a steel casing pipe.
- B. Bentonite: Colloidal clay sold under various trade names that form slick slurry or gel when water is added. Also, known as driller mud.
- C. Carrier Pipe: The tube that carries the product being transported and which may go through casings at highways and railroad crossing. It may be made of steel, concrete, clay, plastic, ductile iron, or other materials.
- D. Casing: A pipe used to line bore holes through which a pipe(s) called carrier pipes or ducts are installed.
- E. Directional Drilling: A steerable system for the installation of pipes, conduits and cables in a shallow arc using a surface launched drilling rig.
- F. Dry Bore: Any drilling or rod pushing system not employing drilling fluid in the process.
- G. Pipe Jacking: A system of directly installing pipes behind a shield machine by hydraulic jacking from a drive shaft such that the pipes form a continuous string in the ground.
- H. Trenchless Technology: Techniques for utility line installation, replacement, rehabilitation, renovation, repair, inspection, location and leak detection, with minimum excavation from the ground surface.

1.4 PERFORMANCE REQUIREMENTS

- A. General Performance:
 - 1. Carrier Pipe: Lateral or vertical variation in pipe's final position from the established Drawing line and grade shall not exceed 1-inch per 10 feet, provided such variation shall be regular, only in one direction, and the final grade of the flow line shall be in the direction indicated on the Drawings.

1.5 PROJECT CONDITIONS

- A. Construction Method: Unless otherwise specifically designated, CONTRACTOR may select jacking, boring, or trenchless construction method to be employed. Gravity sewer lines shall be maintained at a uniform grade throughout trenchless construction.

- B. Permit:
 1. The OWNER shall be responsible to provide the documentation to the appropriate jurisdiction and obtain the required permits for designated jacking, boring, and trenchless operations shown on the Drawings.
 2. For those areas where CONTRACTOR proposed to use jacking, boring, or trenchless excavation operations in lieu of open cut, it shall be the responsibility of the CONTRACTOR to prepare documentation, obtain approval and required permits.
- C. Operation Restrictions: Conduct operations so as not to interfere with, interrupt, or endanger surface and activity thereon.
 1. Minimize subsidence of surface, structures, and utilities above and in vicinity of operations.
 2. Support ground continuously to prevent loss of ground and keep perimeters stable.
 3. Be responsible for settlement resulting from operations.
 4. Repair and restore damaged property to its condition before being disturbed at no cost to the OWNER.
 5. Provide 48-hour notice prior to commencement of any jacking, boring, or trenchless operations.
- D. Compliance: Comply with applicable ordinances, codes, statutes, rules, and regulations of the jurisdictional agency, the affected Railroad, TxDOT, and municipal, state and federal governmental agencies.
- E. Additional Criteria for Work Railroad Property:
 1. Do not schedule work until submittals and insurance approval received from Railroad and ENGINEER and permit, if applicable, has been obtained.
 2. Provide any additional insurance required by the Railroad or other jurisdiction agency.
 3. Comply with AREMA and other Railroad requirements prior to commencing work.
 4. Obtain required Railroad safety training for operators performing work within Railroad right-of-way, the required flagman, and work authorization from the Railroad. All costs associated with these activities shall be the CONTRACTOR's responsibility.
 5. Place safety, precautionary, and protective devices and services required before work proceeds.
- F. Safety Requirements:
 1. Provide flagman, barricades, lights, warning signs, ventilation, air quality monitoring, and other safety devices and equipment required to ensure the safety of personnel entering area and safeguard traffic and pedestrians.
 2. Comply with requirements of Division 31, Section 31 04 01, TRENCH EXCAVATION SAFETY PROTECTION SYSTEM.

PART 2 PRODUCTS

2.1 MATERIALS

- A. General:
 1. Material of construction of casing pipe shall be as designated on the Drawings or as required by the jurisdictional agency for type of service.
 2. Material of construction for the carrier pipe shall be as designated on the Drawings.
 3. Carrier pipe shall be placed inside a casing pipe where foundation conditions (presence of boulders, rubble, or rock) make the direct trenchless installation of the carrier pipe impractical. A casing pipe may also be used if the carrier pipe or conduit is not by itself suitable for trenchless installation.
- B. Casing Pipe:
 1. Steel Pipe:
 - a. Smooth walled steel pipe conforming to ASTM A139/A139M, Grade B; 35,000 psi minimum yield strength.
 - b. Minimum inside diameter shall be as designated on the Plans.
 - c. Minimum wall thickness shall be as designated on the Plans. If not shown on the Plans, minimum wall thickness shall be 3/8-inch for 24-inch diameter and smaller;

- 1/2-inch for 48-inch diameter and smaller, but larger than 24-inch; and 5/8-inch for 66-inch and smaller, but larger than 48-inch.
- d. Joints: Interlocking type, or butt-welded, lap welded, or welded using butt straps in the field. Each end of the casing for butt-welding shall be prepared by providing a 1/4-inch by 45-degree chamfer on the outside edges.
 - e. Coating: None.
- C. Carrier Pipe:
1. Material of construction shall be as shown on the Drawings and shall have restrained joints.
 2. Carrier pipe shall be the same nominal diameter as the system pipe on either side of the carrier pipe.
- D. Casing spacers shall meet one (1) of the following requirements and shall be installed as shown on the Plans.
1. Casing spacers shall be flanged, bolt-on style with a two-section stainless steel shell lined with a PVC liner, minimum 0.09-inch. Runners shall be attached to stainless steel risers, which shall be properly welded to the shell. The height of the runners and risers shall be manufactured such that the pipe does not float within the casing. Casing spacers shall be Cascade Waterworks Manufacturing Company or Advanced Products Systems, Inc. or approved equal.
 2. Casing spacers shall be a two-section, flanged, bolt-on style constructed of heat-fused, PVC-coated steel, minimum 14-gauge band and 10-gauge risers, with two inch (2") wide glass reinforced polyester insulating skids, heavy duty PVC inner liner, minimum 0.09-inch thick and 85-90 durometer hardness, and all stainless steel or cadmium plated hardware shall be Pipeline Seal and Insulator, Inc. or approved equal.
 3. Casing spacers shall be high density polyethylene. Spacers shall be RACI spacers or approved equal.
- E. Casing End Seals:
1. Manufactured of 1/8-inch thick neoprene rubber, attached using 1/2-inch wide T304 stainless steel banding's 100% non-magnetic worm gear mechanism.
 2. Configuration may be pull-on end molded, wrap around with self-curing mastic sealing strips, or zipper configuration.
 3. Available Manufacturers:
 - a. Advance Products & Systems, Inc.
 - b. Cascade Waterworks Mfg.
 - c. Pipeline Seal & Insulator Inc.
- F. Grout:
1. Consist of one part Portland cement, ASTM C150/C150M, Type I or II, three parts sand, and minimum amount of water to obtain desired consistency.
 2. Sand shall consist of clean, hard, durable, uncoated grains, free from lumps and organic material. All particles shall pass a No. 8 sieve and the material shall have a plasticity index of 12 or less.
 3. Compressive strength of 100 psi at 28 days.
- G. Flowable Fill:
1. Ready mixed flowable fill is a blend of cement, fly ash, fine aggregate, and water. It is designed as a low strength, flowable material requiring no subsequent vibration or tamping to achieve 100% consolidation.
 2. Unless indicated otherwise, select and proportion ingredients to obtain compressive strength between 50 and 150 psi at 28 days in accordance with ASTM D4832.
 3. Materials:
 - a. Cement: ASTM C150/C150M, Type I, II, or III.
 - b. Aggregate: ASTM C33/C33M, Size 8 or fine aggregate.
 - c. Fly Ash (if used): ASTM C618, Class C.
 - d. Water: Clean, potable, free of odor, organics, and deleterious materials.

4. The flowable fill mixture shall be mixed either in a pug mill, concrete mixer, or transit mixer and shall have a minimum slump of five (5) inches.

PART 3 EXECUTION

3.1 GENERAL

- A. Unless soil borings in the immediate vicinity of the work area are available, CONTRACTOR shall investigate the existing soils and subsurface conditions so the appropriate equipment is provided to counter conditions which can cause delay, such as groundwater, running sand, boulders, or other subsurface conditions.

3.2 CONSTRUCTION BY JACKING

- A. Construct suitable pits or trenches at the jacking and receiving end to a depth no greater than required for placing of the guide and jacking timbers and a horizontal distance no nearer the roadbed than minimum distance shown on the Drawings.
- B. All open pits and trenches shall be braced and shored or their walls sloped preventing caving or sliding of the walls into the open pit or trench complying with requirements of Section 31 04 01, TRENCH EXCAVATION SAFETY PROTECTION SYSTEM.
- C. Place pipe on guides for supporting pipe to be jacked and to direct it for proper alignment and grade. Embankment material shall be excavated just ahead of the pipe, removed through the pipe, and the pipe forced through the opening provided.
- D. Excavation for the underside of the pipe, for at least one-third (1/3) of the pipe circumference, shall conform to the contour and grade of the pipe. Excavation for the top half of the pipe shall conform closely to the outside diameter and a clearance greater than 2 inches shall not be permitted. Preferably pipe shall be jacked from the low or downstream end.
- E. All voids between the pipe and the earth shall be filled with grout. Provide grout holes in the pipe. The grouting shall follow immediately upon completion of the jacking operation. Backfill pits and trenches as soon as practical following completion of jacking operations and installation of carrier pipe(s).
- F. Any pipe that cannot be repaired to its original condition or is damaged during jacking operations shall be removed and replaced at CONTRACTOR's expense.

3.3 CONSTRUCTION BY BORING

- A. Construct suitable pits or trenches at the boring and receiving end to a depth no greater than required for placing of the guide and jacking timbers and a horizontal distance no nearer the roadbed than minimum distance shown on the Drawings.
- B. All open pits and trenches shall be braced and shored or their walls sloped preventing caving or sliding of the walls into the open pit or trench complying with requirements of Section 31 04 01, TRENCH EXCAVATION SAFETY PROTECTION SYSTEM.
- C. The hole shall be bored mechanically with a suitable boring assemble designed to produce a smooth, straight shaft and so operated that the completed shaft shall be at the established line and grade. The boring shall be accomplished using either a pilot hole method or a dry hole method.
 1. Pilot Hole Method: Bore approximately a 2-inch pilot hole the entire length of the crossing and confirm line and grade. The pilot hole shall serve as the centerline for the larger diameter hole to be bored.
 2. Dry Hole Method: Advance casing pipe as augers through the casing pipe remove the soil. Bentonite may be used as a lubricant.
- D. All voids between the pipe and the earth shall be filled with grout. Provide grout holes in the pipe. The grouting shall follow immediately upon completion of the jacking operation. Backfill pits and trenches as soon as practical following completion of jacking operations and installation of carrier pipe(s).
- E. Any pipe that cannot be repaired to its original condition or is damaged during boring operations shall be removed and replaced at CONTRACTOR's expense.

3.4 CARRIER PIPE INSTALLATION

- A. Installation:

1. Install carrier pipe to establish lines and grades.
 2. Carrier pipe joints within the casing pipe shall be of the restrained type in accordance with applicable pipe specifications. If applicable, exterior and interior joints of the carrier pipe shall be mortar coated and lined in the field as installation progresses.
 3. For cast iron or ductile iron, encase pipe in polyethylene in accordance with applicable pipe section.
 4. Install casing spacers by placing at each end of the casing pipe and at 6 to 8 foot intervals, and in accordance with manufacturer instructions. There shall be at least two spacers installed on each pipe section.
 5. Seal ends of casing and carrier pipe using neoprene casing end seals and stainless steel bands. If overlap seal is employed, bond together the overlapping surfaces with permanent sealing adhesive.
- B. Testing: Hydrostatic testing of the carrier pipe shall be completed prior to the filling of the annular space between the casing and carrier pipe. Testing shall be accomplished in accordance with the applicable pipe section.
- C. Backfilling Annular Space between Carrier Pipe and Casing Pipe: Backfill annular space using sand or flowable fill.
- D. Supports: Carrier pipe shall be supported to the quarter point by a concrete cradle across the boring or jacking pit to the first joint in the ditch section at each end.

3.5 CONSTRUCTION BY GUIDED BORING OR DIRECTIONAL BORING

- A. Guided boring or directional drilling shall be accomplished according to the standards in "Trenchless Technology Guidelines" published by International Society of Trenchless Technology.

3.6 FIELD QUALITY CONTROL

- A. Grade and Alignment. Provide field survey data confirming grade and alignment conforms to values shown on the Drawings and within limits of specified in this Section.
- B. Provide test data for materials used in installing casing and carrier pipe, such as grout, concrete, flowable fill, and sand used to fill annular space between carrier pipe and casing.
- C. Provide settlement measurements. During construction, make observations of settlement markers at regular intervals of roadway and railroad tracks. Record and provide information.

-- END OF SECTION --

SECTION 33 06 01 - MISCELLANEOUS WATER LINE MATERIALS

PART 1 GENERAL

1.1 REFERENCE STANDARDS

- ASME B16.26 - Cast Copper Alloy Fittings for Flared Copper Tubes; 2013.
- ASTM A536 - Standard Specification for Ductile Iron Castings; 1984 (Reapproved 2014).
- ASTM B61 - Standard Specification for Steam or Valve Bronze Castings; 2015.
- ASTM B62 - Standard Specification for Composition Bronze or Ounce Metal Castings; 2015.
- ASTM B88 - Standard Specification for Seamless Copper Water Tube; 2014.
- ASTM D3139 - Standard Specification for Joints for Plastic Pressure Pipes using Flexible Elastomeric Seals; 1998 (Reapproved 2011).
- ASTM D3350 - Standard Specification for Polyethylene Plastics Pipe and Fittings Material; 2014.
- AWWA C502 - Dry-Barrel Fire Hydrants; 2014.
- AWWA C703 - Cold-Water Meters -- Fire-Service Type; 2015.
- AWWA C706 - Direct-Reading, Remote-Registration Systems for Cold- Water Meters; Latest Edition.
- AWWA C707 - Encoder-Type Remote-Registration Systems for Cold-Water Meters; 2010.
- AWWA C800 - Underground Service Line Valves and Fittings; 2014.
- NSF 61 - Drinking Water System Components - Health Effects; 2014 (Errata 2015).
- UL 262 - Gate Valves for Fire-Protection Service; Current Edition, Including All Revisions.

1.2 WORK INCLUDED

The CONTRACTOR shall furnish, install and test (as needed) all materials needed to complete this Project as described in these Specifications.

1.3 QUALITY ASSURANCE

- A. This item of the Specifications covers the type and/or quality of materials common to other sections of the Specifications. These Specifications are intended to be so written that only materials of the best quality and grade will be furnished. The fact that the Specifications may fail to be sufficiently complete in some detail will not relieve the CONTRACTOR of full responsibility for providing materials of high quality and protecting them adequately until incorporation in the Project. The Specifications for materials set out the minimum standard of quality which the OWNER believes necessary to procure a satisfactory Project. No substitutions will be permitted until the CONTRACTOR has received written permission from the ENGINEER to make a substitution for the material which has been specified.
- B. Where the term "or equal", or "or approved equal" is used, it is understood that if a material, product, or piece of equipment of the specified name and quality is furnished it will be approvable, as the particular name was used for the purpose of establishing a standard of quality acceptable to the OWNER. If a product of any other name is proposed for use, the ENGINEER's approval thereof must be obtained before the proposed substitute is procured by the CONTRACTOR. Wherever the term "or equal" is used, it is understood to mean "or approved equal".
- C. In the event the type or quality of materials required for installation on the project are inadvertently omitted from these Specifications, it is the intent that only high quality materials meeting industry accepted standards be furnished and installed by the CONTRACTOR. Such omission of materials Specifications shall be directed to the attention of the ENGINEER by the CONTRACTOR and materials shall receive approval by the ENGINEER prior to purchase. All materials used on this project shall be new.

1.4 SUBMITTALS

Submit the following information in accordance with the requirements of the Contract Documents:

- A. Pipe material
- B. Fittings and appurtenances

The pipe layout Drawings and data shall clearly indicate where pipe requiring special provisions are provided.

PART 2 PRODUCTS

2.1 MEGA-LUG JOINT RESTRAINTS

The CONTRACTOR shall furnish and install Megalug Joint Restraints Series 2000PV, as manufactured by EBAA Iron, for all mechanical joint fittings and valves. The joint restraints shall comply with the requirements of ASTM D3139. The joint restraints shall be adaptable for use with C-900 or IPS PVC Pipe.

2.2 RETAINER GLANDS

Retainer glands for restraining cast iron mechanical joint fittings used with PVC pipe shall be cast from high strength ductile iron, ASTM A536 Grade 65-45-12. Glands shall be Uni-Flange Series 1300 Restrainer, or approved equal. Retainer glands for restraining cast iron mechanical joint fittings used with ductile iron pipe shall be cast from 60-40-10 ductile iron. Glands shall be EBAA Iron Series 100, or approved equal.

2.3 TAPPING SLEEVES

- A. Tapping sleeves of the sizes indicated for connection to existing main shall be the stainless steel, split-sleeve type with mechanical joint outlet, and with bolts, follower rings and gaskets on each end of the sleeve. Construction shall be suitable for a maximum working pressure of 150 psi. Bolts shall have square heads and hexagonal nuts. Longitudinal gaskets and mechanical joints with gaskets shall be as recommended by the manufacturer of the sleeve.
- B. Approved tapping sleeve manufacturers:
 - 1. Power Seal Model 3490

2.4 FIRE HYDRANTS

- A. Fire hydrants shall be standard three-way, 5¼" valve opening, two 2½" nozzles and one pump nozzle, 150 psi working pressure, complying with AWWA C502. Fire hydrants shall be Mueller or approved equal, with mechanical joint inlet. Megalug joint restraints shall be used from the fire hydrant to the tee. The fire hydrants shall be red in color and any damage to the point shall be repaired by the Supplier.
- B. Approved fire hydrant manufacturers:
 - 1. M&H
 - 2. Mueller
 - 3. EJIW

2.5 FIRE HYDRANT REFLECTIVE MARKERS

The CONTRACTOR shall furnish and install blue fire hydrant reflectors at each fire hydrant location. The reflector locations shall be as shown on the Construction Drawings.

2.6 METAL DETECTABLE TAPE

- A. Detectable marking tape shall consist of one layer of metalized foil laminated between two layers of inert plastic film. The lamination bond shall be strong enough that the layers cannot be separated by hand. Tape shall be a minimum of 5 mils thick with a minimum tensile strength of 56 pounds per 2-inch width strip. Tape shall be imprinted with a continuous warning message repeated every 30 inches. It shall be inductively locatable and conductively traceable using a standard pipe and cable locating device for a minimum of 8 years after direct burial at 18-inch depth. Test results showing minimum 8-year life must be furnished with the submittals.
- B. Tape for this project shall be 2 inches wide, blue in color on one side with black lettering. The warning message shall read "CAUTION WATER LINE BURIED BELOW." The tape shall be as manufactured by Reef Industries, Inc., Houston, Texas, or an approved equal. The water line ditch shall be backfilled to 18 inches below ground level; backfill shall be graded uniformly; then the tape shall be laid continuously in the center of the ditch line with lettered side up. Tape shall be installed for all water line trench except through casing and the tape shall be pulled into valves boxes for access.

PART 3 EXECUTION

3.1 INSTALLATION

The CONTRACTOR shall install miscellaneous water line materials in accordance with manufacturer's written instructions, and in accordance with recognized industry practices to ensure that the components serve their intended purpose.

-- END OF SECTION --

ATTACHMENT B: TSTC FIRE LOOP CONSTRUCTION DRAWINGS
PLANS FOR

TEXAS STATE TECHNICAL COLLEGE 10-INCH FIRE LOOP

AUGUST 2019

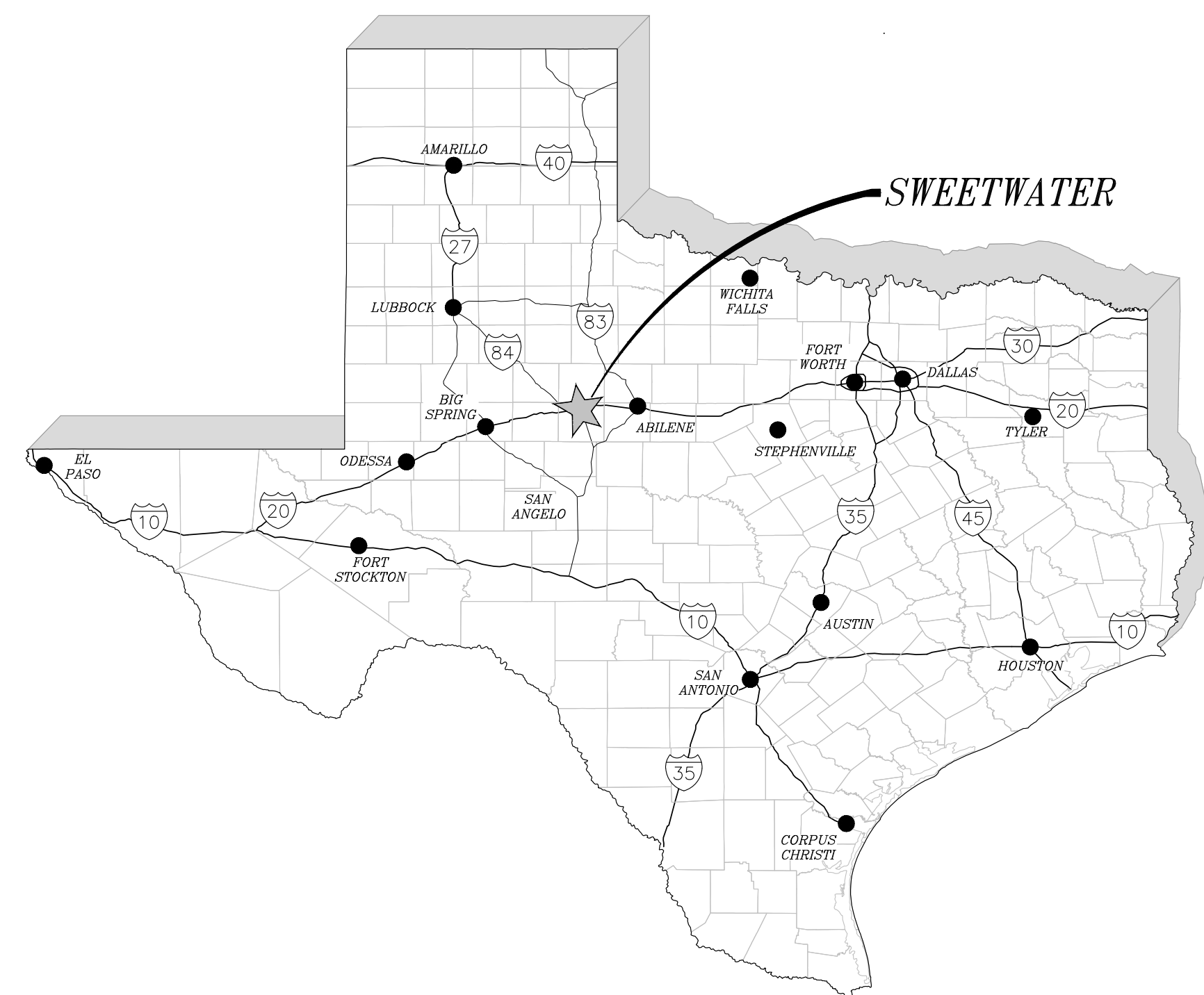

PROJECT VICINITY MAP

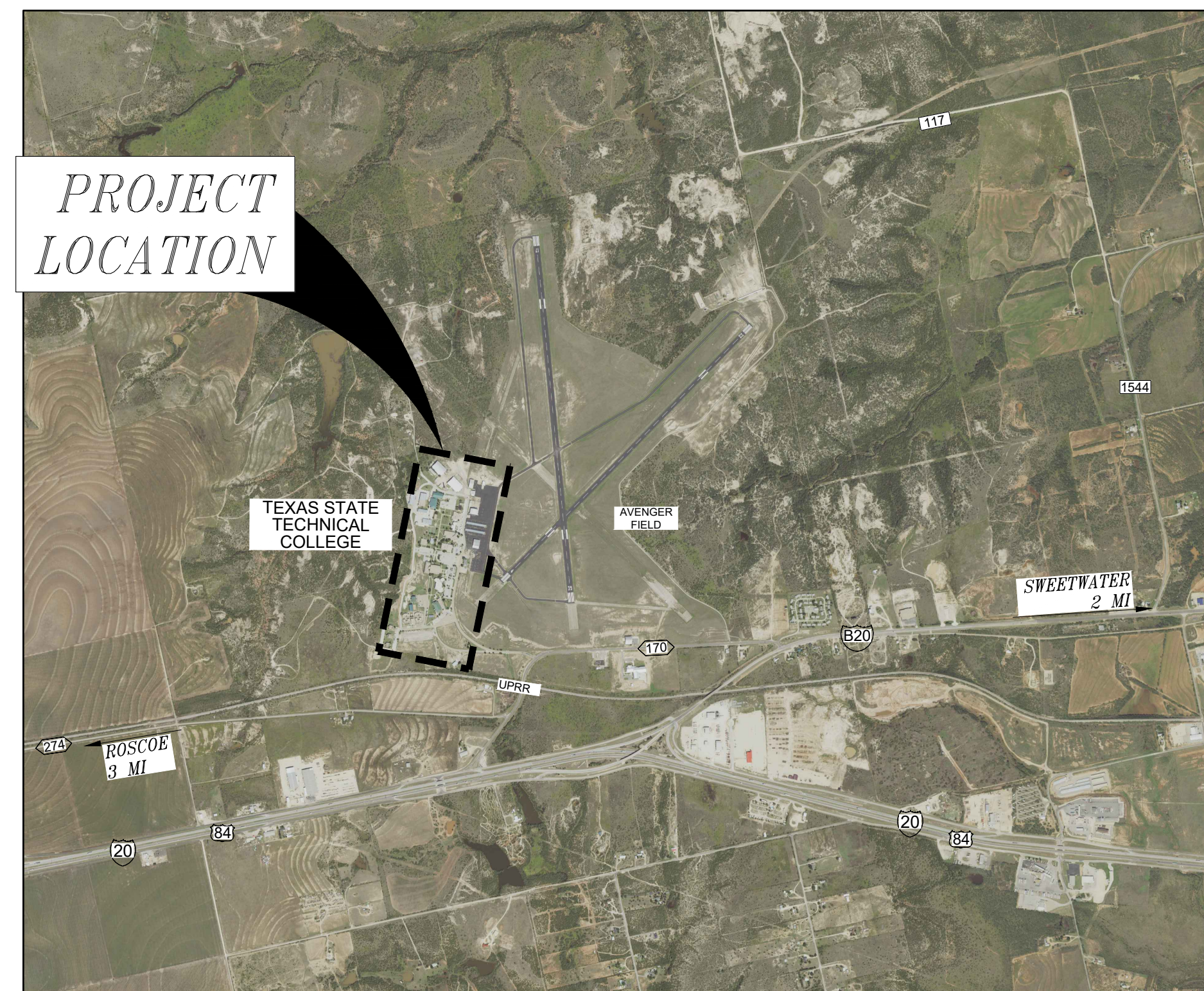
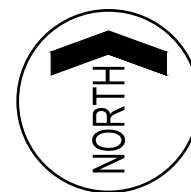

PROJECT LOCATION MAP

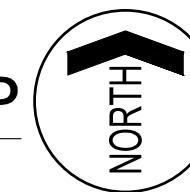

3465 CURRY LANE
ABILENE, TX 79606
325-695-1070
1508 SANTA FE DR, STE 204
WEATHERFORD, TX 76086
817-594-9880
1014 BROADWAY STREET
LUBBOCK, TX 79401
806-368-6375
FIRM# F-2448



X:\GM_TexasStateTechnicalCollege\19111 - TSTC Fire Loop Project\Drafting\Plans\C:\cva\Sheet 01 MAP_SHEET INDEX_LEGEND.dwg Saved By: ron Save Time: 8/21/2019 9:53 AM Plotted by: Trevor Green Plot Date: 8/22/2019 10:13 AM

LEGEND

	EXISTING WATER METER
	EXISTING WATER VALVE
	EXISTING IRRIGATION VALVE
	EXISTING FLUSH VALVE
	EXISTING FIRE HYDRANT
	EXISTING SIGN
	EXISTING LIGHT POLE
	EXISTING ASPHALT SURFACE
	EXISTING CONCRETE SURFACE
	EXISTING OVERHEAD ELECTRIC
	EXISTING FENCE
	EXISTING WATER LINE
	EXISTING SEWER LINES

LEGEND

	PROPOSED WATER LINE
	PROPOSED PIPE BORE ENCASEMENT
	PROPOSED HYDRANT (PLAN VIEW)
	PROPOSED REDUCER
	PROPOSED COUPLING
	PROPOSED VALVE
	PROPOSED TEE
	PROPOSED CROSS
	PROPOSED 90° ELL
	PROPOSED BEND FITTING
	PROPOSED CAP

SHEET LIST

00	COVER SHEET
01	LEGEND, SHEET INDEX, AND SHEET LIST
02	CONSTRUCTION NOTES
03	HOMER K. TAYLOR DR WATER LINE PLAN STA 0+00 - 5+00
03	HOMER K. TAYLOR DR WATER LINE PLAN STA 5+00 - 10+00
04	HOMER K. TAYLOR DR WATER LINE PLAN STA 10+00 - 20+00
05	HOMER K. TAYLOR DR WATER LINE PLAN STA 20+00 - 30+50
06	HOMER K. TAYLOR DR WATER LINE PLAN STA 30+50 - 42+00
07	HOMER K. TAYLOR DR WATER LINE PLAN STA 42+00 - 52+54
08	FIRE HYDRANT REMOVAL PLAN
09	WATER LINE DETAILS (1)
10	WATER LINE DETAILS (2)
11	WATER LINE DETAILS (3)

SHEET INDEX

SCALE: 1"=100'



3465 CUPRY LANE
 ABILENE, TX 79606
 325-695-1070
 1508 SANTA FE DR, STE 204
 WEATHERFORD, TX 76086
 817-594-9880
 1014 BROADWAY STREET
 LUBBOCK, TX 79401
 806-368-6375



TEXAS STATE TECHNICAL COLLEGE

10-INCH FIRE LOOP

LEGEND, SHEET INDEX SHEET LIST

NO.	REVISION	DATE	SCALE	AS SHOWN	PROJECT #	DESIGNED	DRAWN	CHECKED
					19111	HKH	RLM	HKH
SHEET 01 SEQ. 01 OF 11								

BAR IS ONE INCH IN LENGTH ON ORIGINAL DRAWING.
 CHECK SCALE & ADJUST ACCORDINGLY.

X:\DM_TexasStateTechnicalCollege\19111 - TSTC Fire Loop Project\Drafting\Plans\C_Civil\Sheet 02 CONSTRUCTION NOTES.dwg Saved By: tgreen Save Time: 8/22/2019 10:04 AM Plotted by: Trevor Green Plot Date: 8/22/2019 10:13 AM

TCEQ WATER DISTRIBUTION SYSTEM GENERAL CONSTRUCTION NOTES

- This water distribution system must be constructed in accordance with the current Texas Commission on Environmental Quality (TCEQ) Rules and Regulations for Public Water Systems 30 Texas Administrative Code (TAC) Chapter 290 Subchapter D. When conflicts are noted with local standards, the more stringent requirement shall be applied. At a minimum, construction for public water systems must always meet TCEQ's "Rules and Regulations for Public Water Systems."
- All newly installed pipes and related products must conform to American National Standards Institute (ANSI)/NSF International Standard 61 and must be certified by an organization accredited by ANSI [§290.44(a)(1)].
- Plastic pipe for use in public water systems must bear the NSF International Seal of Approval (NSF-pw) and have an ASTM design pressure rating of at least 150 psi or a standard dimension ratio of 26 or less [§290.44(a)(2)].
- No pipe which has been used for any purpose other than the conveyance of drinking water shall be accepted or relocated for use in any public drinking water supply [§290.44(a)(3)].
- All water line crossings of wastewater mains shall be perpendicular [§290.44(e)(4)(B)].
- Water transmission and distribution lines shall be installed in accordance with the manufacturer's instructions. However, the top of the water line must be located below the frost line and in no case shall the top of the water line be less than 24 inches below ground surface [§290.44(a)(4)].
- The maximum allowable lead content of pipes, pipe fittings, plumbing fittings, and fixtures is 0.25 percent [§290.44(b)].
- The contractor shall install appropriate air release devices with vent openings to the atmosphere covered with 16-mesh or finer, corrosion resistant screening material or an acceptable equivalent [§290.44(d)(1)].
- The contractor shall not place the pipe in water or where it can be flooded with water or sewage during its storage or installation [§290.44(f)(1)].
- When waterlines are laid under any flowing or intermittent stream or semi-permanent body of water the waterline shall be installed in a separate watertight pipe encasement. Valves must be provided on each side of the crossing with facilities to allow the underwater portion of the system to be isolated and tested [§290.44(f)(2)].

Revised February 2019

Page 1 of 3

- Pursuant to 30 TAC §290.44(a)(5), the hydrostatic leakage rate shall not exceed the amount allowed or recommended by the most current AWWA formulas for PVC pipe, cast iron and ductile iron pipe. Include the formulas in the notes on the plans.
 - The hydrostatic leakage rate for polyvinyl chloride (PVC) pipe and appurtenances shall not exceed the amount allowed or recommended by formulas in America Water Works Association (AWWA) C-605 as required in 30 TAC §290.44(a)(5). Please ensure that the formula for this calculation is correct and most current formula is in use;

$$Q = \frac{LD\sqrt{P}}{148,000}$$

Where:

- Q = the quantity of makeup water in gallons per hour,
- L = the length of the pipe section being tested, in feet,
- D = the nominal diameter of the pipe in inches, and
- P = the average test pressure during the hydrostatic test in pounds per square inch (psi).

- The hydrostatic leakage rate for ductile iron (DI) pipe and appurtenances shall not exceed the amount allowed or recommended by formulas in America Water Works Association (AWWA) C-600 as required in 30 TAC §290.44(a)(5). Please ensure that the formula for this calculation is correct and most current formula is in use;

$$L = \frac{SD\sqrt{P}}{148,000}$$

Where:

- L = the quantity of makeup water in gallons per hour,
- S = the length of the pipe section being tested, in feet,
- D = the nominal diameter of the pipe in inches, and
- P = the average test pressure during the hydrostatic test in pounds per square inch (psi).

- The contractor shall maintain a minimum separation distance in all directions of nine feet between the proposed waterline and wastewater collection facilities including manholes. If this distance cannot be maintained, the contractor must immediately notify the project engineer for further direction. Separation distances, installation methods, and materials utilized must meet §290.44(e)(1)-(4).
- The separation distance from a potable waterline to a wastewater main or lateral manhole or cleanout shall be a minimum of nine feet. Where the nine-foot separation distance cannot be achieved, the potable waterline shall be encased in a joint of at least 150 psi pressure class pipe at least 18 feet long and two nominal sizes larger than the new conveyance. The space around the carrier pipe shall be supported at five-foot intervals with spacers or be filled to the springline with washed sand. The encasement pipe shall be centered on the crossing and both ends sealed with cement grout or manufactured sealant [§290.44(e)(5)].
- Fire hydrants shall not be installed within nine feet vertically or horizontally of any wastewater line, wastewater lateral, or wastewater service line regardless of construction [§290.44(e)(6)].

Revised February 2019

Page 2 of 3

- Suction mains to pumping equipment shall not cross wastewater mains, wastewater laterals, or wastewater service lines. Raw water supply lines shall not be installed within five feet of any tile or concrete wastewater main, wastewater lateral, or wastewater service line [§290.44(e)(7)].
- Waterlines shall not be installed closer than ten feet to septic tank drainfields [§290.44(e)(8)].
- The contractor shall disinfect the new waterlines in accordance with AWWA Standard C-651-14 or most recent, then flush and sample the lines before being placed into service. Samples shall be collected for microbiological analysis to check the effectiveness of the disinfection procedure which shall be repeated if contamination persists. A minimum of one sample for each 1,000 feet of completed waterline will be required or at the next available sampling point beyond 1,000 feet as designated by the design engineer [§290.44(f)(3)].
- Dechlorination of disinfecting water shall be in strict accordance with current AWWA Standard C655-09 or most recent.

Revised February 2019

Page 3 of 3

GENERAL CONSTRUCTION NOTES:

- CONTRACTOR TO FIELD VERIFY SIZE AND LOCATION OF ALL UTILITIES PRIOR TO CONSTRUCTION. (TEXAS ONE CALL SYSTEM 1-800-545-6005). CONTRACTOR SHALL PROTECT ALL EXISTING UTILITIES WHICH ARE TO REMAIN. BURIED UTILITIES SHOWN ON THE PLANS HAVE BEEN ESTABLISHED BY ON GROUND INFORMATION AS WELL AS COORDINATION WITH UTILITY COMPANIES. LOCATIONS MAY NOT BE EXACT AND OTHER UTILITIES MAY EXIST.
- WORK SHALL BE CONDUCTED IN A WAY AS TO MINIMIZE INTERFERENCE WITH TRAFFIC. CONTRACTOR SHALL PROVIDE ADVANCED WARNING CONSTRUCTION SIGNING AND TYPE III BARRICADES WITH "ROAD CLOSED" SIGNS, LOCATED AT THE START OF CONSTRUCTION. ALL SIGNING AND BARRICADES PROVIDED SHALL BE IN ACCORDANCE WITH THE TEXAS MANUAL ON UNIFORM TRAFFIC CONTROL DEVICES (TMUTCD).
- PRIOR TO COMMENCEMENT OF CONSTRUCTION, ALL PARTIES THAT MEET THE DEFINITION OF OPERATOR AS DEFINED BY THE TEXAS COMMISSION ON ENVIRONMENTAL QUALITY (TCEQ) TPDES CONSTRUCTION GENERAL PERMIT TXR150000 SHALL SUBMIT REQUIRED NOTIFICATION WHICH MAY INCLUDE A COPY OF THE NOTICE OF INTENT (NOI) FILED WITH THE TCEQ AND/OR A CONSTRUCTION SITE NOTICE (CSN). A COPY OF THE NOI OR THE CSN SHALL BE PROVIDED TO THE CITY. THE NOI/CSN FORMS AND PERMIT REQUIREMENTS MAY BE OBTAINED FROM TCEQ AT www.tceq.state.tx.us/nav/permits/wq_construction.html. A STORM WATER POLLUTION PREVENTION PLAN (SWP3) SHALL BE DEVELOPED AND IMPLEMENTED PRIOR TO COMMENCEMENT OF CONSTRUCTION. QUESTIONS CONCERNING THESE REQUIREMENTS MAY BE ADDRESSED TO TCEQ SMALL BUSINESS LOCAL GOVERNMENT ASSISTANCE PROGRAM AT 800-447-2827.
- ALL EXCAVATION GREATER THAN 5 FEET DEEP SHALL COMPLY WITH O.S.H.A. TRENCH SAFETY STANDARDS.
- ALL MATERIAL INSTALLATION SHALL FULLY COMPLY WITH TAC TCEQ CHAPTER 290 FOR NO EXTRA PAYMENT. CHAPTER 290 REQUIREMENTS SHALL TAKE PRIORITY OVER ALL OTHER SPECIFICATIONS, PLANS AND CONTRACT DOCUMENTS.
- ALL MATERIAL FOR THIS PROJECT SHALL BE FURNISHED BY THE CONTRACTOR. ALL MATERIAL FOR THIS PROJECT SHALL BE INSTALLED BY THE CONTRACTOR.
- CONTRACTOR SHALL CONTACT A REPRESENTATIVE FROM THE GAS COMPANY BEFORE COMPLETING GAS LINE CROSSINGS.
- NO CHANGE IN THE WORK PERFORMED SHALL BE AUTHORIZED WITHOUT APPROVAL OF THE ENGINEER.
- THE CONTRACTOR SHALL FULLY COMPLY WITH ALL TCEQ REGULATIONS PERTAINING TO SEPARATION DISTANCES AS DESCRIBED IN SECTION 290.44 OF THE TAC.
- ALL PIPE AND ACCESSORIES SHALL BE LAID, JOINTED TESTED FOR DEFECTS AND LEAKAGE WITH PRESSURE AND DISINFECTED ACCORDING TO AWWA CM651-05. CONTRACTOR SHALL MAINTAIN APPROPRIATE BACK FLOW PREVENTION ACCORDING TO AWWA C651-05 SECTION 4.3.9.

- ALL ABANDONED FIRE HYDRANTS SHALL BE REMOVED & DISPOSED OF BY THE CONTRACTOR.
- THE CONTRACTOR SHALL CONTROL EROSION AND SEDIMENTATION PER THE APPLICABLE PERMITS, LAWS, AND REGULATIONS
- CONTRACTOR SHALL MINIMIZE DAMAGE TO EXISTING LANDSCAPING ON PRIVATE PROPERTY. EXISTING LANDSCAPING SHALL BE REPAIRED TO ITS ORIGINAL CONDITION INCLUDING THE REPLACEMENT OF EXISTING LAWN AREAS WITH THE SAME TYPE OF LAWN AS WAS REMOVED.
- ALL ABOVE GROUND STRUCTURES SHALL BE PROTECTED BY THE CONTRACTOR FROM DAMAGE DURING THE CONSTRUCTION PROCESS. ANY DAMAGE DONE ON PRIVATE PROPERTY SHALL BE REPLACED OR REPAIRED TO ORIGINAL OR BETTER CONDITIONS.
- NO EXTRA PAYMENT WILL BE MADE FOR SPECIAL PROVISIONS REQUIRED TO MEET TCEQ REGULATIONS WHEN WATER & SEWER LINES CROSS OR WHEN THEY ARE LAID PARALLEL PER DETAILS & PER TCEQ REGS.
- CONTRACTOR SHALL SPRAY ALL FITTINGS, SADDLES, CORP STOP, ETC WITH BLEACH SOLUTION AS FOLLOWS: 1 GAL BLEACH / 4 GALLON POTABLE WATER.
- TO BE ELIGIBLE TO BID, THE BIDDER MUST HAVE BEEN A UTILITY CONTRACTOR FOR AT LEAST 5 YEARS AND BE A TEXAS LICENSED UTILITY CONTRACTOR.
- A TEXAS LICENSED WATER OPERATOR (WITH A MINIMUM OF A "C" LICENSE) HAS TO BE IN CHARGE OF FLUSHING AND DISINFECTION OF LINES..
- ALL MATERIALS TESTING FOR TRENCH SECTION BACKFILL SHALL BE PROVIDED BY OWNER'S THROUGH THE ENGINEER. CONTRACTOR SHALL COORDINATE MATERIALS TESTING WITH OWNER; RESIDENT REPRESENTATIVE.

PROJECT COORDINATION AND SEQUENCE OF CONSTRUCTION:

- CONTRACTOR SHALL COORDINATE ALL CONSTRUCTION ACTIVITIES WITH TSTC ADMINISTRATION AND STAFF.
- CONTRACTOR SHALL MAINTAIN AN OPEN LANE ALONG HOMER K. TAYLOR DRIVE, THE PRIMARY ROAD AROUND CAMPUS, AT ALL TIMES DURING CONSTRUCTION OF THE WATER LINE.
- A MINIMUM OF ONE ACCESS POINT TO ALL PARKING LOTS SHALL BE MAINTAINED AT ALL TIMES DURING CONSTRUCTION OF THE WATER LINES.
- CONTRACTOR SHALL CONTACT CITY OF SWEETWATER WATER & WASTEWATER DEPARTMENT (325-235-4166) TO SCHEDULE AND COORDINATE TAPPING OF CITY MAIN.



8465 CURRY LANE
ASILENE, TX 79606
325-695-1070

1508 SANTA FE DR, STE 204
WEATHERFORD, TX 76086
817-594-9880

1014 BROADWAY STREET
LUBBOCK, TX 79401
806-365-6375

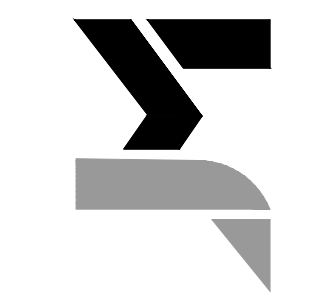

TEXAS STATE TECHNICAL COLLEGE

10-INCH FIRE LOOP

CONSTRUCTION NOTES

NO.	REVISION	DATE	SCALE	AS SHOWN	PROJECT #	DESIGNED	DRAWN	CHECKED
					19111	HKH	RLM	HKH

BAR IS ONE INCH IN LENGTH ON ORIGINAL DRAWING. CHECK SCALE & ADJUST ACCORDINGLY.

SHEET 02

SEQ. 02 OF 11

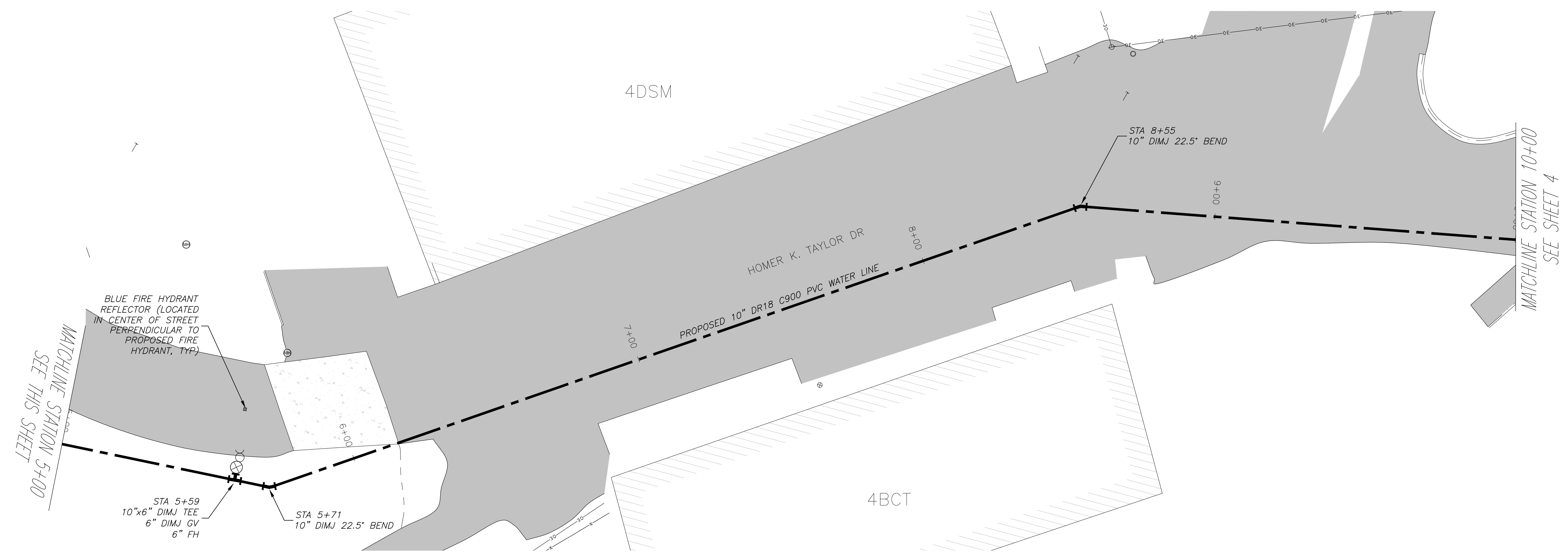
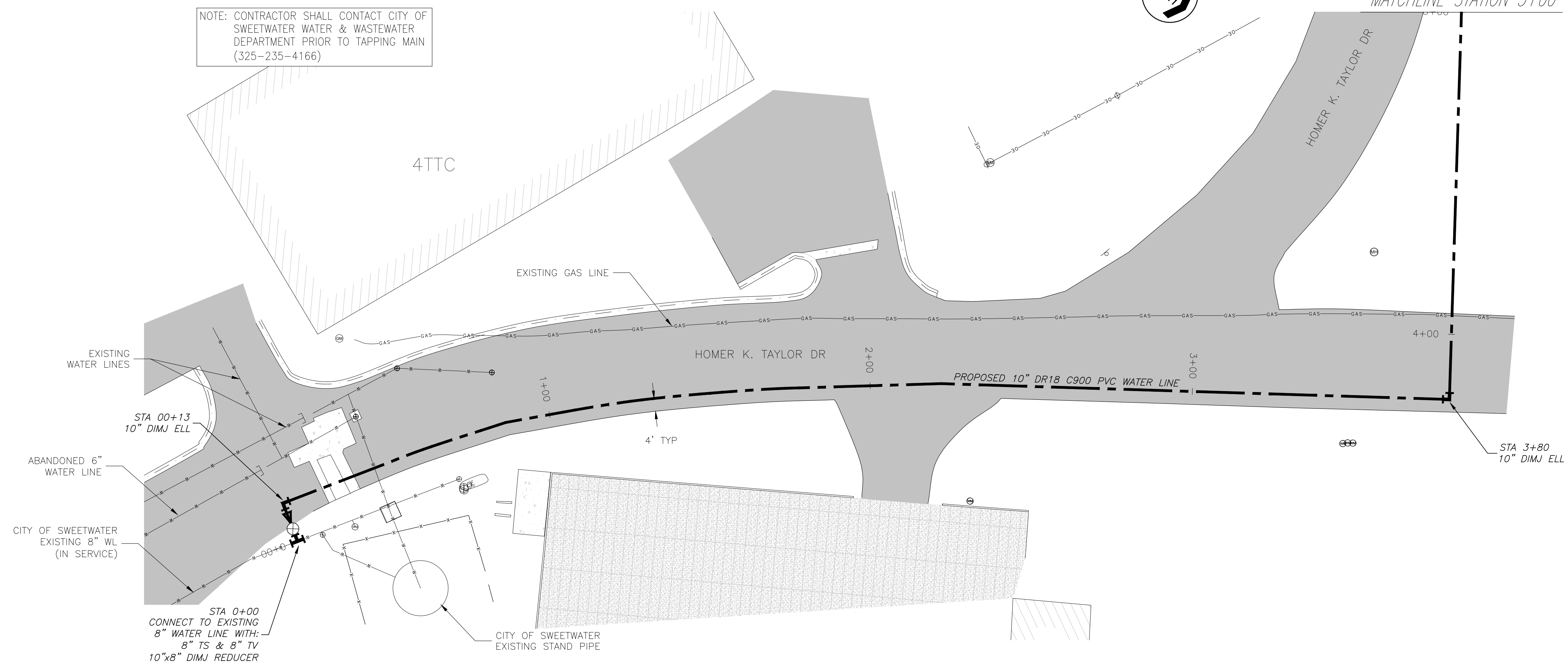

3465 CURY LANE
ASILENE, TX 79606
325-695-1070

1508 SANTA FE DR, STE 204
WEATHERFORD, TX 76086
817-594-9880

1014 BROADWAY STREET
LUBBOCK, TX 79401
806-365-6375

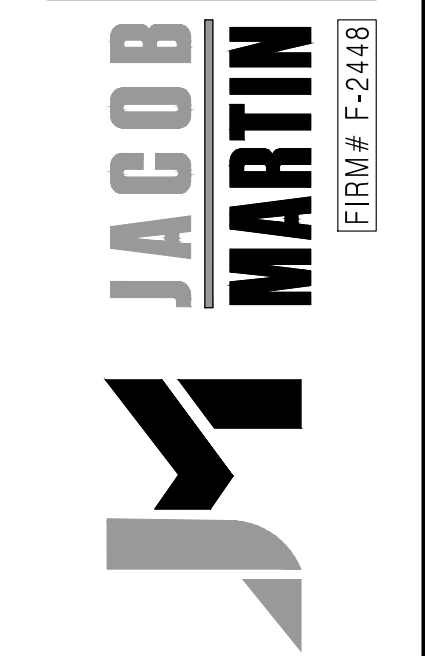

TEXAS STATE TECHNICAL COLLEGE
10-INCH FIRE LOOP
WATER LINE PLAN
STA: 0+00 - 10+00

SCALE	1" = 20'
PROJECT #	19111
DESIGNED	HKH
DRAWN	RLM
CHECKED	HKH
SHEET 03	
SEQ. 03 OF 11	

BAR IS ONE INCH IN LENGTH ON ORIGINAL DRAWING. CHECK SCALE & ADJUST ACCORDINGLY.

X:\GM_TexasStateTechnicalCollege\19111 - TSTC Fire Loop Project\Drafting\Plans\C:\cva\sheet 04 WATER LINE PLAN.dwg Saved By: ron Save Time: 8/21/2019 1:25 PM Plotted by: Trevor Green Plot Date: 8/22/2019 10:13 AM

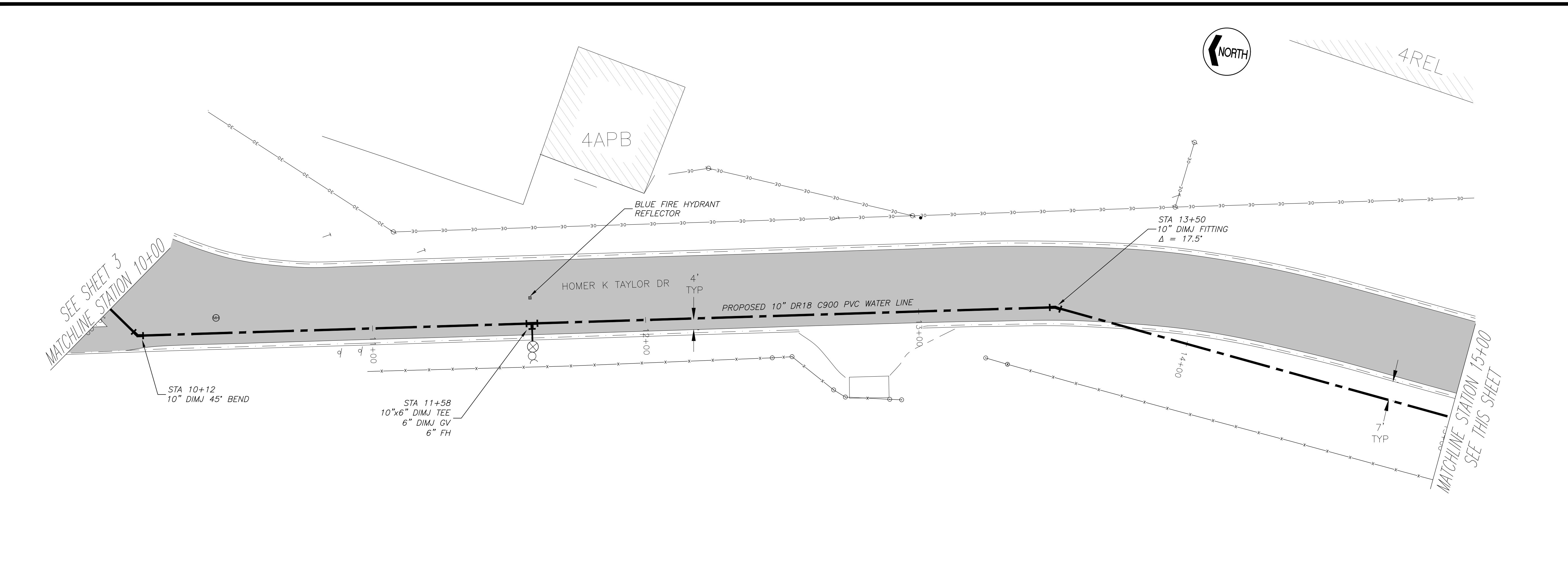
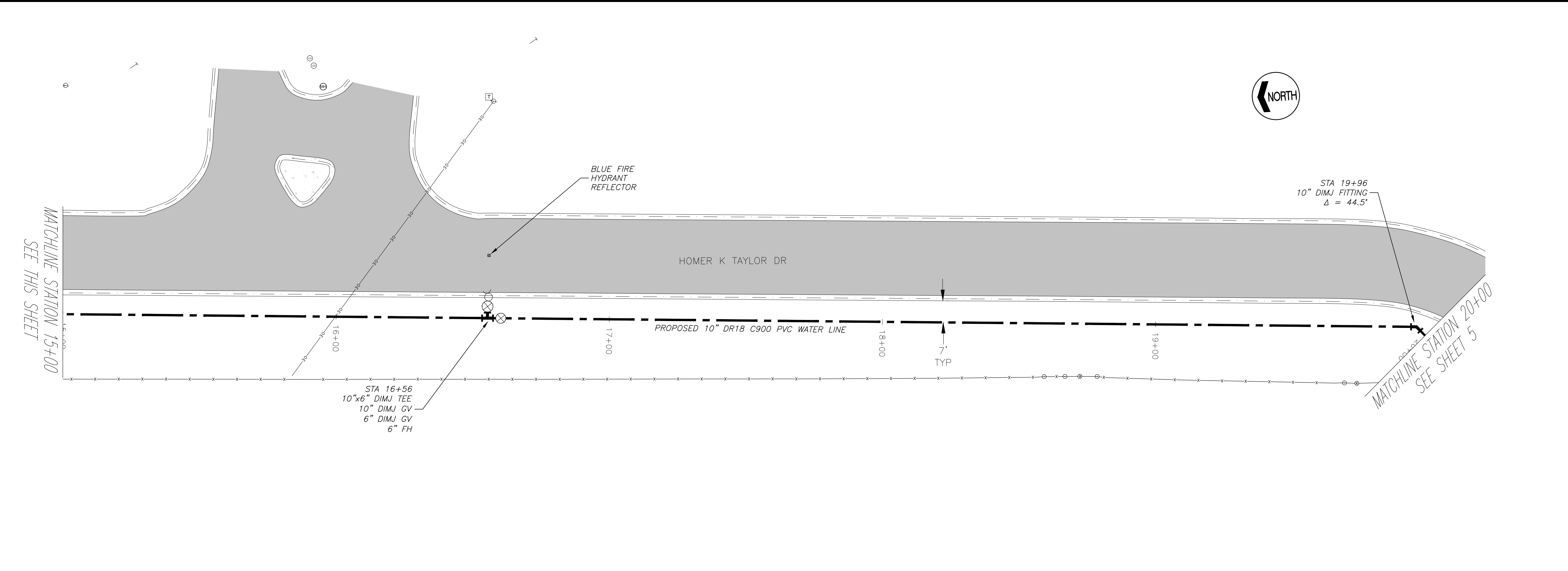

<p>3465 CURRY LANE ASILENE, TX 79606 825-695-1070</p> <p>1508 SANTA FE DR, STE 204 WEATHERFORD, TX 76066 817-594-9880</p> <p>1014 BROADWAY STREET LUBBOCK, TX 79401 806-365-6375</p>												
<p>JACOB MARTIN FIRM# F-2448</p>												
<p>TEXAS STATE TECHNICAL COLLEGE 10-INCH FIRE LOOP WATER LINE PLAN STA: 10+00 - 20+00</p>												
NO.	REVISION	DATE	SCALE	1" = 20'	PROJECT #	19111	DESIGNED	HKH	DRAWN	RLM	CHECKED	HKH
<p>BAR IS ONE INCH IN LENGTH ON ORIGINAL DRAWING. CHECK SCALE & ADJUST ACCORDINGLY.</p>												
SHEET 04											SEQ. 04 OF 11	

X:\GM_TexasStateTechnicalCollege\19111 - TSTC Fire Loop Project\Drafting\Plans\Civil\Sheet 05 WATER LINE PLAN.dwg Saved By: tgreen Save Time: 8/22/2019 10:05 AM Plotted by: Trevor Green Plot Date: 8/22/2019 10:13 AM

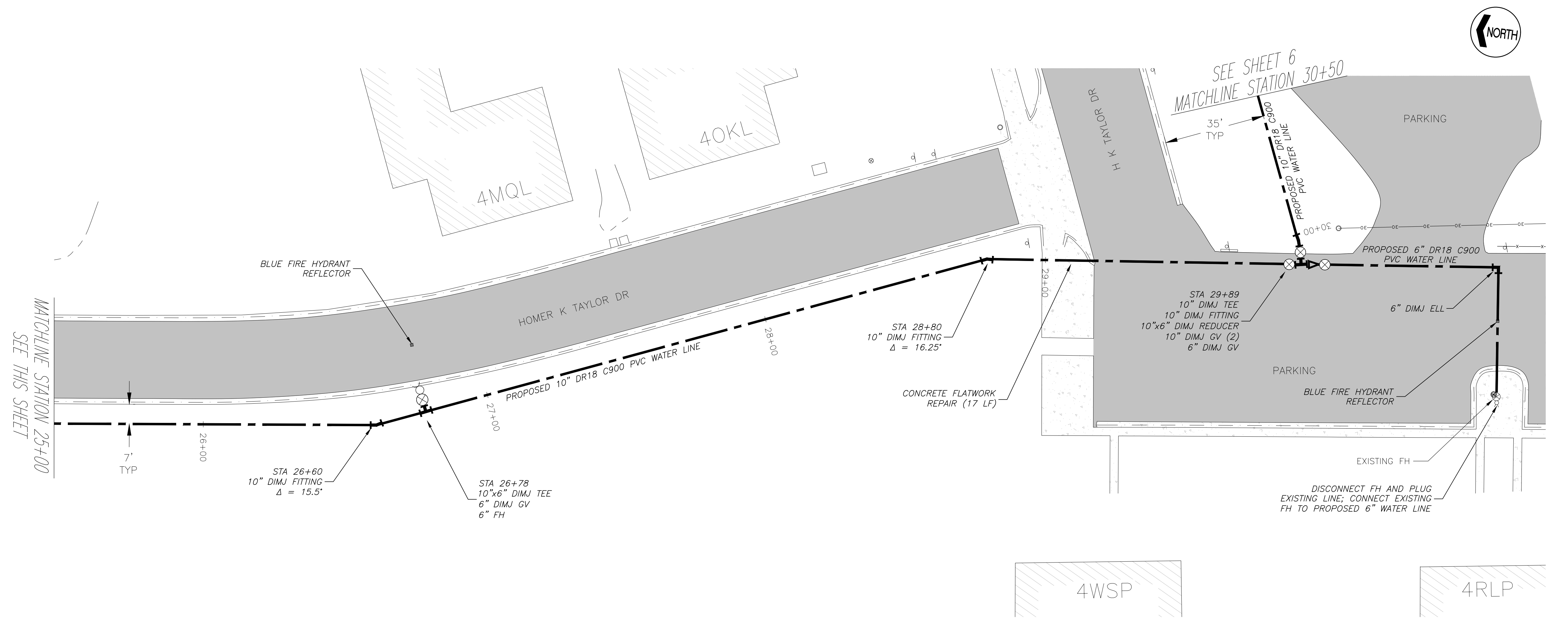
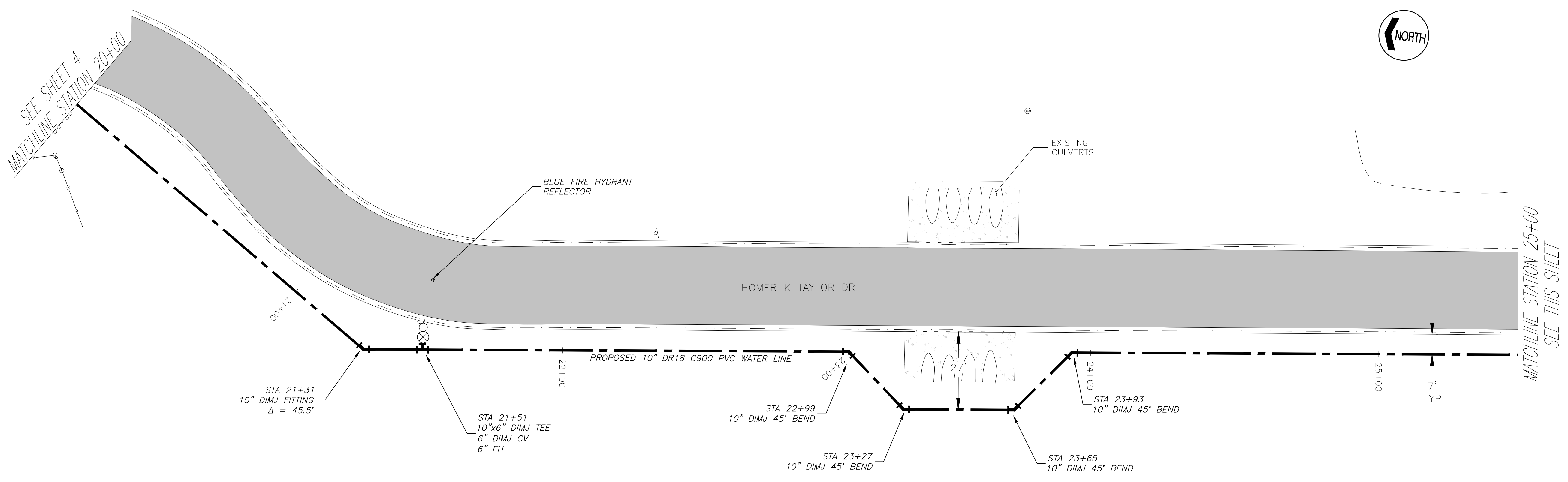

3465 CURRY LANE
ASILENE, TX 79606
825-695-1070

1508 SANTA FE DR, STE 204
WEATHERFORD, TX 76086
817-594-9880

1014 BROADWAY STREET
LUBBOCK, TX 79401
806-365-6375

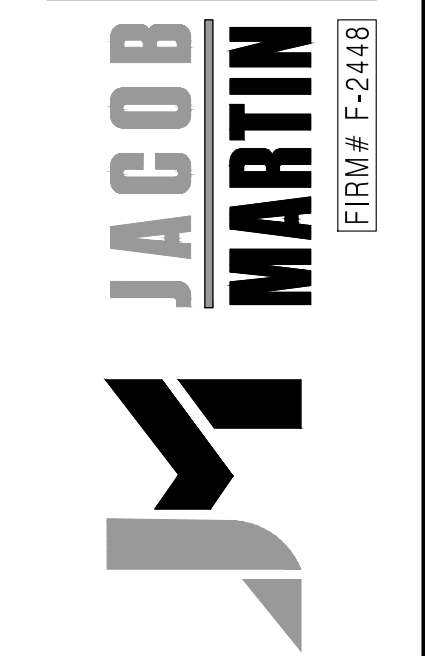

TEXAS STATE TECHNICAL COLLEGE
10-INCH FIRE LOOP
WATER LINE PLAN
STA: 20+00 - 30+50

SCALE	1" = 20'
PROJECT #	19111
DESIGNED	HKH
DRAWN	RLM
CHECKED	HKH
DATE	
NO.	REVISION
SHEET	05
SEQ.	05 OF 11

BAR IS ONE INCH IN LENGTH ON ORIGINAL DRAWING.
CHECK SCALE & ADJUST ACCORDINGLY.

MATCHLINE STATION 30+50
SEE SHEET 5

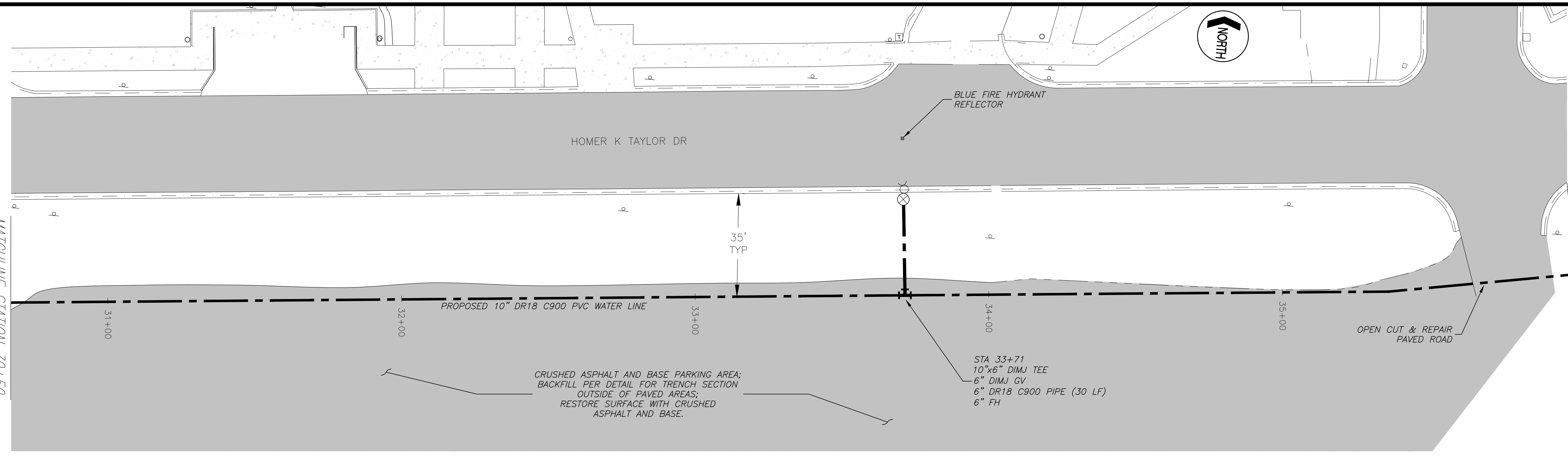

MATCHLINE STATION 36+00
SEE THIS SHEET

SEE THIS SHEET
MATCHLINE STATION 36+00

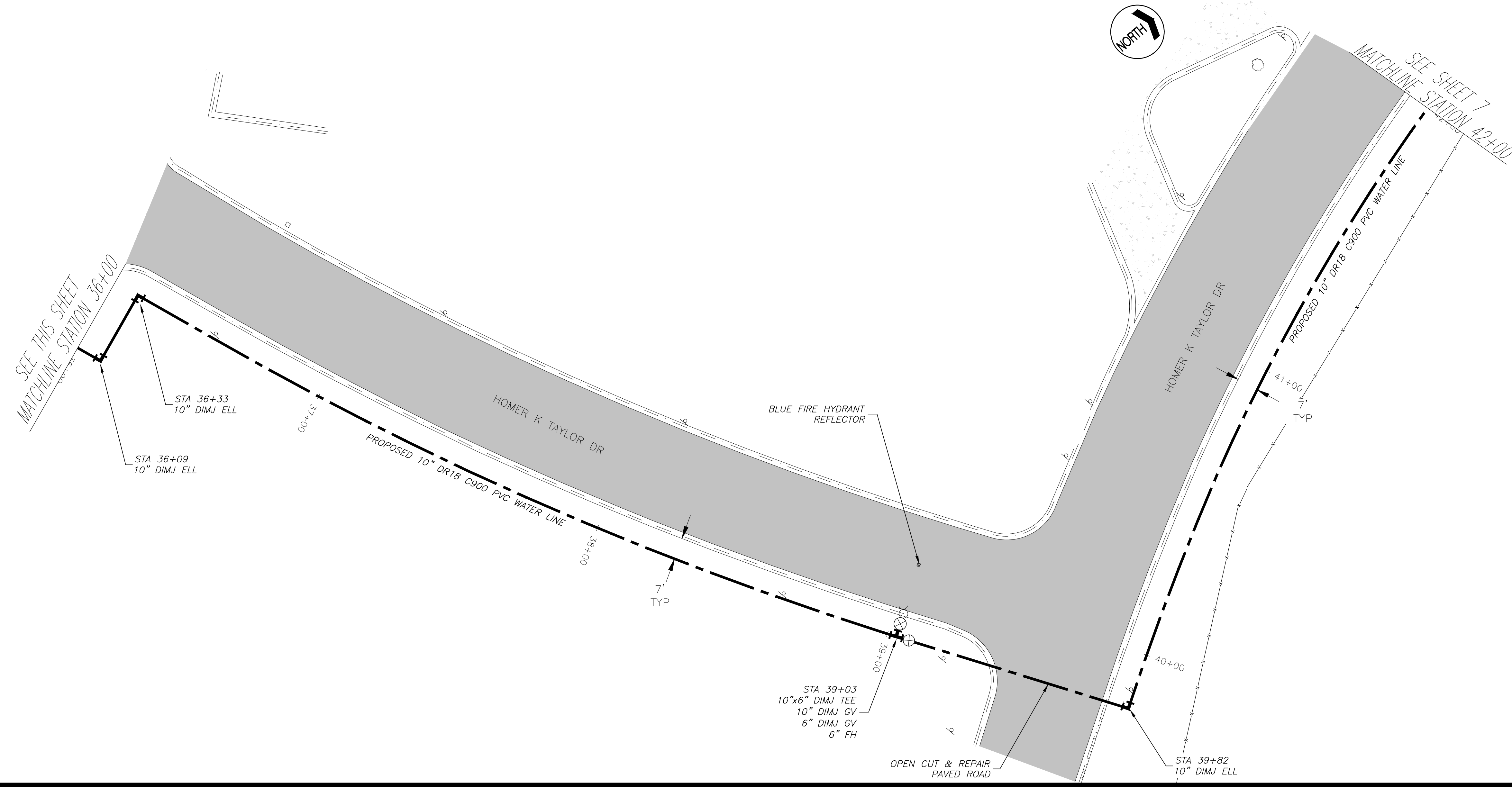

SEE SHEET 7
MATCHLINE STATION 42+00



3465 CURRY LANE
ASILENE, TX 79606
325-695-1070
1508 SANTA FE DR, STE 204
WEATHERFORD, TX 76086
817-594-9880
1014 BROADWAY STREET
LUBBOCK, TX 79401
806-365-6375

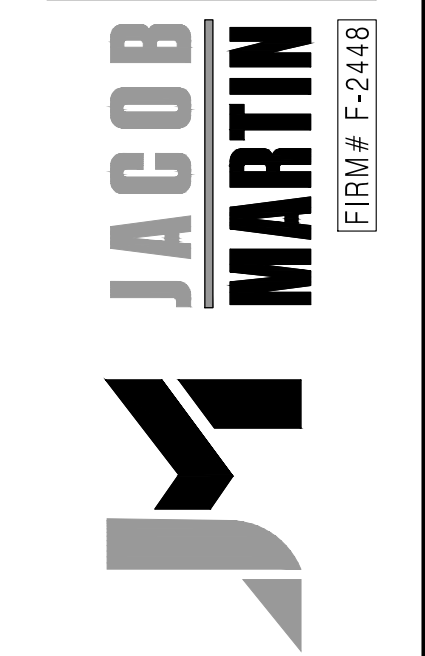

TEXAS STATE TECHNICAL COLLEGE
10-INCH FIRE LOOP
WATER LINE PLAN
STA: 30+50 - 42+00

NO.	REVISION	DATE	SCALE	1" = 20'
			PROJECT #	19111
			DESIGNED	HKH
			DRAWN	RLM
			CHECKED	HKH
SHEET 06				
SEQ. 06 OF 11				

BAR IS ONE INCH IN LENGTH ON ORIGINAL DRAWING.
CHECK SCALE & ADJUST ACCORDINGLY.

X:\DM_TexasStateTechnicalCollege\19111 - TSTC Fire Loop Project\Drafting\Plans\Civil\Sheet 07 WATER LINE PLAN.dwg Saved By: ron Save Time: 8/21/2019 11:29 AM Plotted by: Trevor Green Plot Date: 8/22/2019 10:14 AM

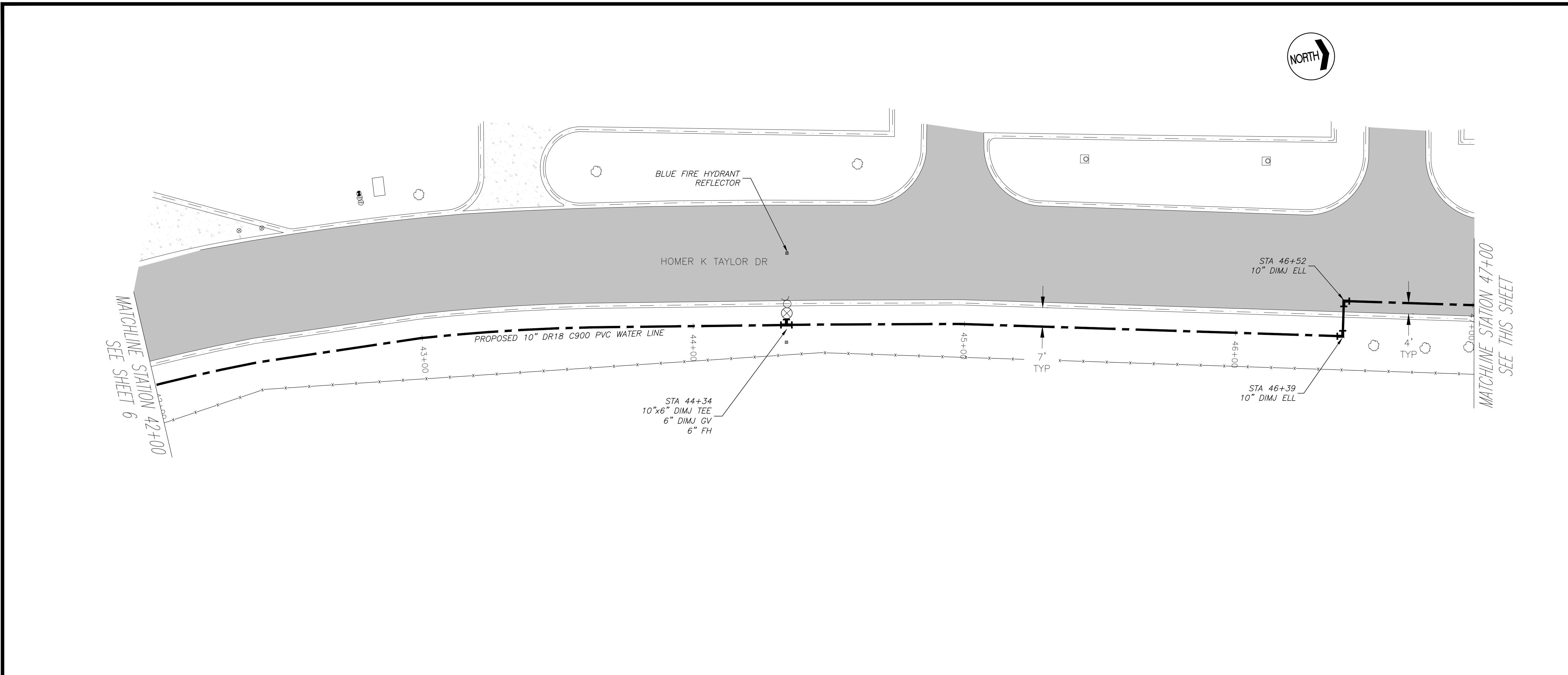
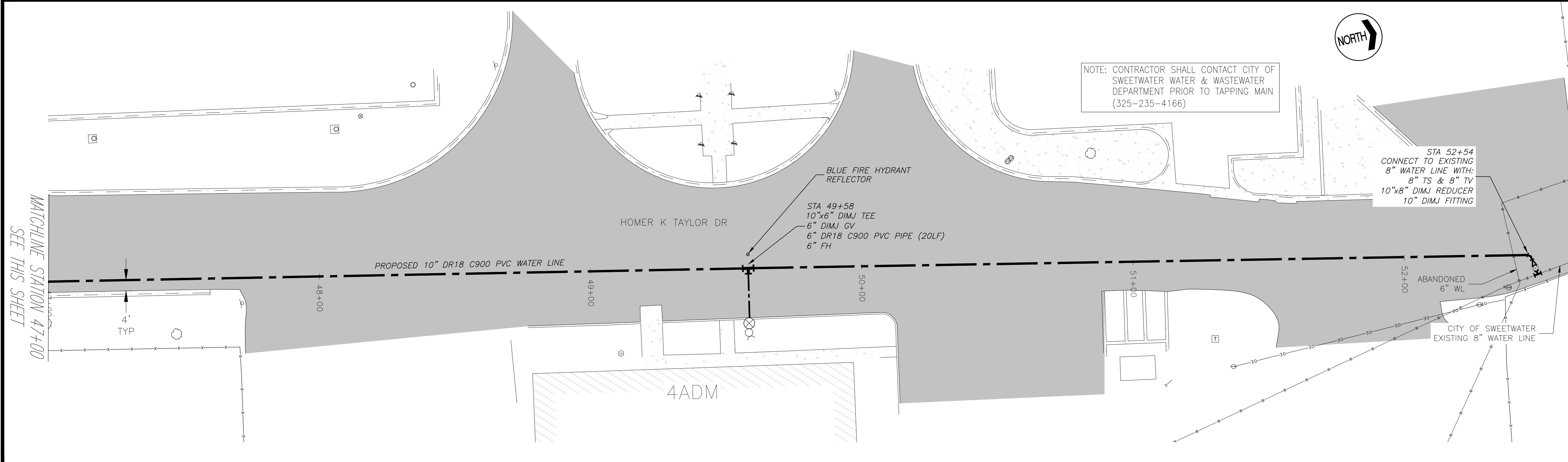

NOTE: CONTRACTOR SHALL CONTACT CITY OF SWEETWATER WATER & WASTEWATER DEPARTMENT PRIOR TO TAPPING MAIN (325-235-4166)

STA 52+54
CONNECT TO EXISTING
8" WATER LINE WITH:
8" TS & 8" TV
10"x8" DIMJ REDUCER
10" DIMJ FITTING

CITY OF SWEETWATER
EXISTING 8" WATER LINE

3465 CURRY LANE
ASILENE, TX 79606
325-695-1070

1508 SANTA FE DR, STE 204
WEATHERFORD, TX 76066
817-594-9880

1014 BROADWAY STREET
LUBBOCK, TX 79401
806-365-6375

JACOB MARTIN
FIRM # F-2448

TEXAS STATE TECHNICAL COLLEGE
10-INCH FIRE LOOP
WATER LINE PLAN
STA: 42+00 - 52+54

NO.	REVISION	DATE	SCALE	PROJECT #	DESIGNED	DRAWN	CHECKED
			1" = 20'	19111	HKH	RLM	HKH

BAR IS ONE INCH IN LENGTH ON ORIGINAL DRAWING.
CHECK SCALE & ADJUST ACCORDINGLY.

SHEET 07
SEQ. 07 OF 11

X:\DM_TexasStateTechnicalCollege\19111 - TSTC Fire Loop Project\Drafting\Plans\Civil\Sheet 08 FIRE HYDRANT REMOVAL PLAN.dwg
 Saved By: ron
 Save Time: 8/21/2019 11:31 AM
 Plotted by: Trevor Green
 Plot Date: 8/22/2019 10:14 AM

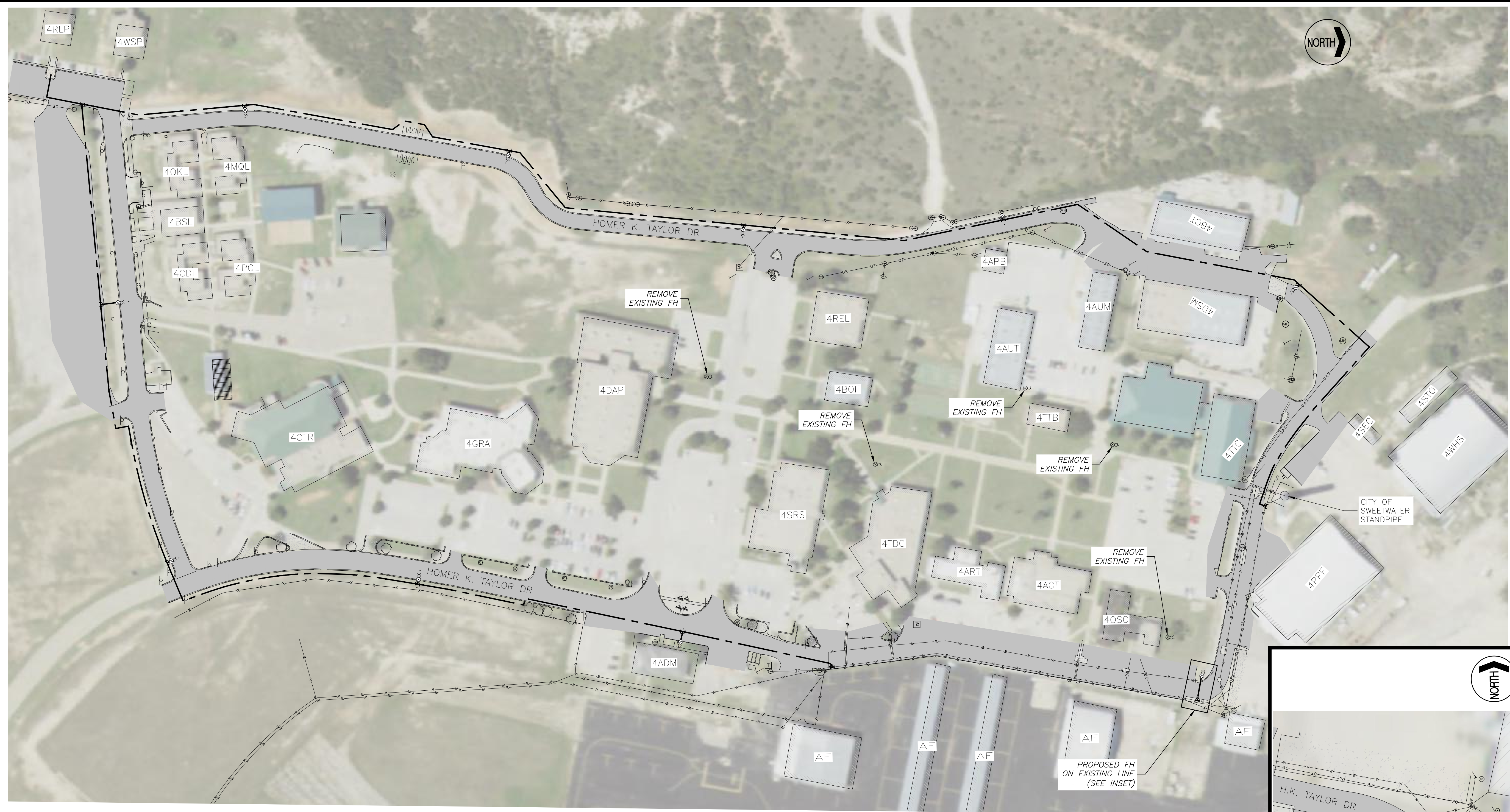

FIRE HYDRANT REMOVAL NOTES:

1. FIRE HYDRANTS SHOWN FOR REMOVAL SHALL BE REMOVED AT THE FIRE HYDRANT BOOT.
2. EXISTING FIRE HYDRANT ISOLATION GATE VALVE AND BOX SHALL BE REMOVED.
3. REMOVED FIRE HYDRANTS SHALL BE DELIVERED TO THE OWNER OR DISPOSED OF BY CONTRACTOR AT OWNERS REQUEST.
4. EXISTING WATER LINE SUPPLYING FIRE HYDRANTS TO BE REMOVED SHALL BE PLUGGED AND BLOCKED WITH CONCRETE THRUST BLOCKING.

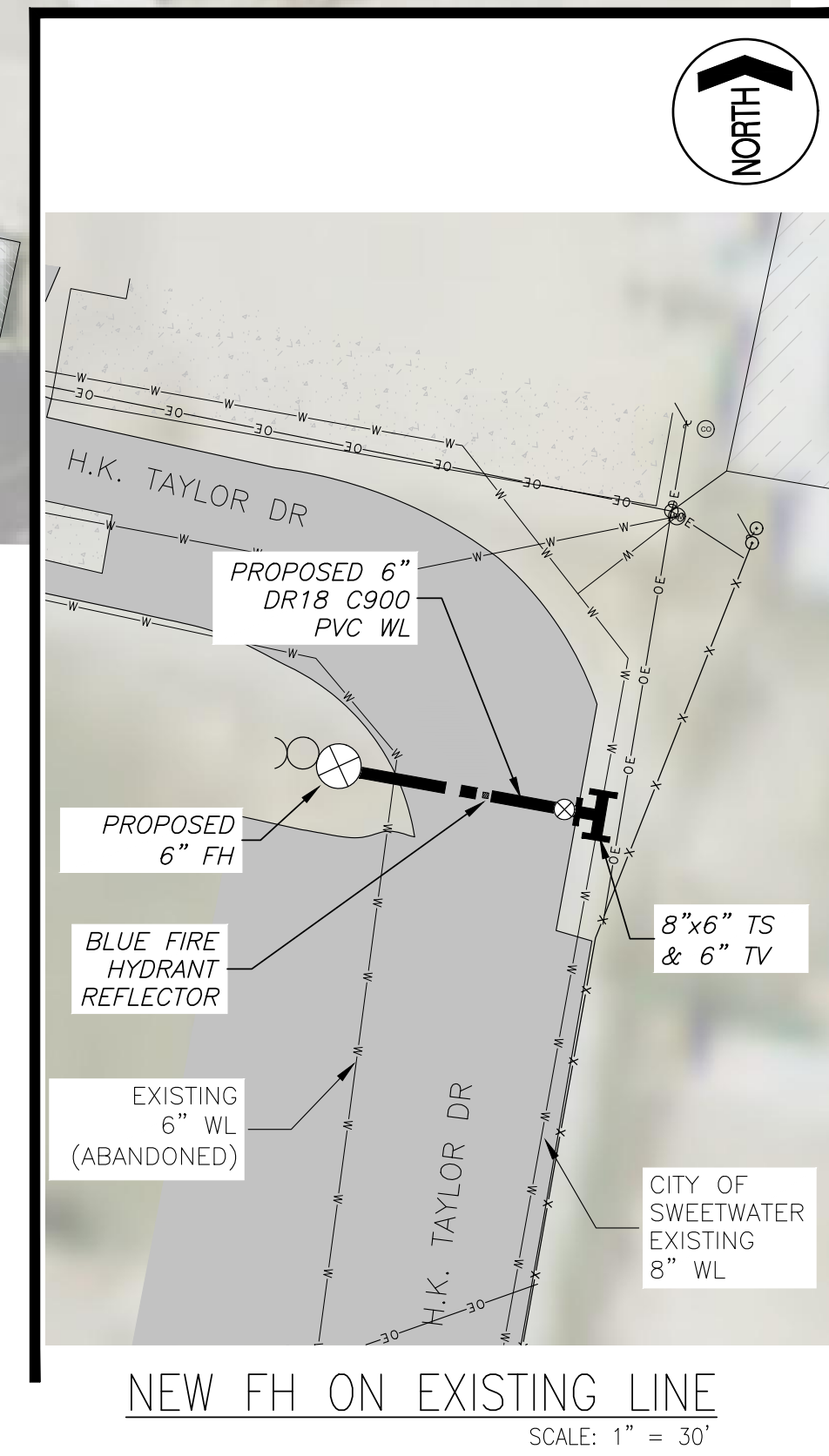

3485 CURY LANE
 ASILENE, TX 79606
 325-695-1070
 1508 SANTA FE DR, STE 204
 WEATHERFORD, TX 76086
 817-594-9880
 1014 BROADWAY STREET
 LUBBOCK, TX 79401
 806-368-6375



TEXAS STATE TECHNICAL COLLEGE
 10-INCH FIRE LOOP
 FIRE HYDRANT REMOVAL PLAN

SCALE	1" = 100'
PROJECT #	19111
DESIGNED	HKH
DRAWN	RLM
CHECKED	HKH
DATE	
NO.	REVISION
SHEET 08	
SEQ. 08 OF 11	

BAR IS ONE INCH IN LENGTH ON ORIGINAL DRAWING.
 CHECK SCALE & ADJUST ACCORDINGLY.

X:\GM_TexasStateTechnicalCollege\19111 - TSTC Fire Loop Project\Drafting\Plans\C.DWG\SHEET 09 DETAILS (1).dwg
 Saved By: non
 Save Time: 8/21/2019 1:11 PM
 Plotted by: Trevor Green
 Plot Date: 8/22/2019 10:14 AM

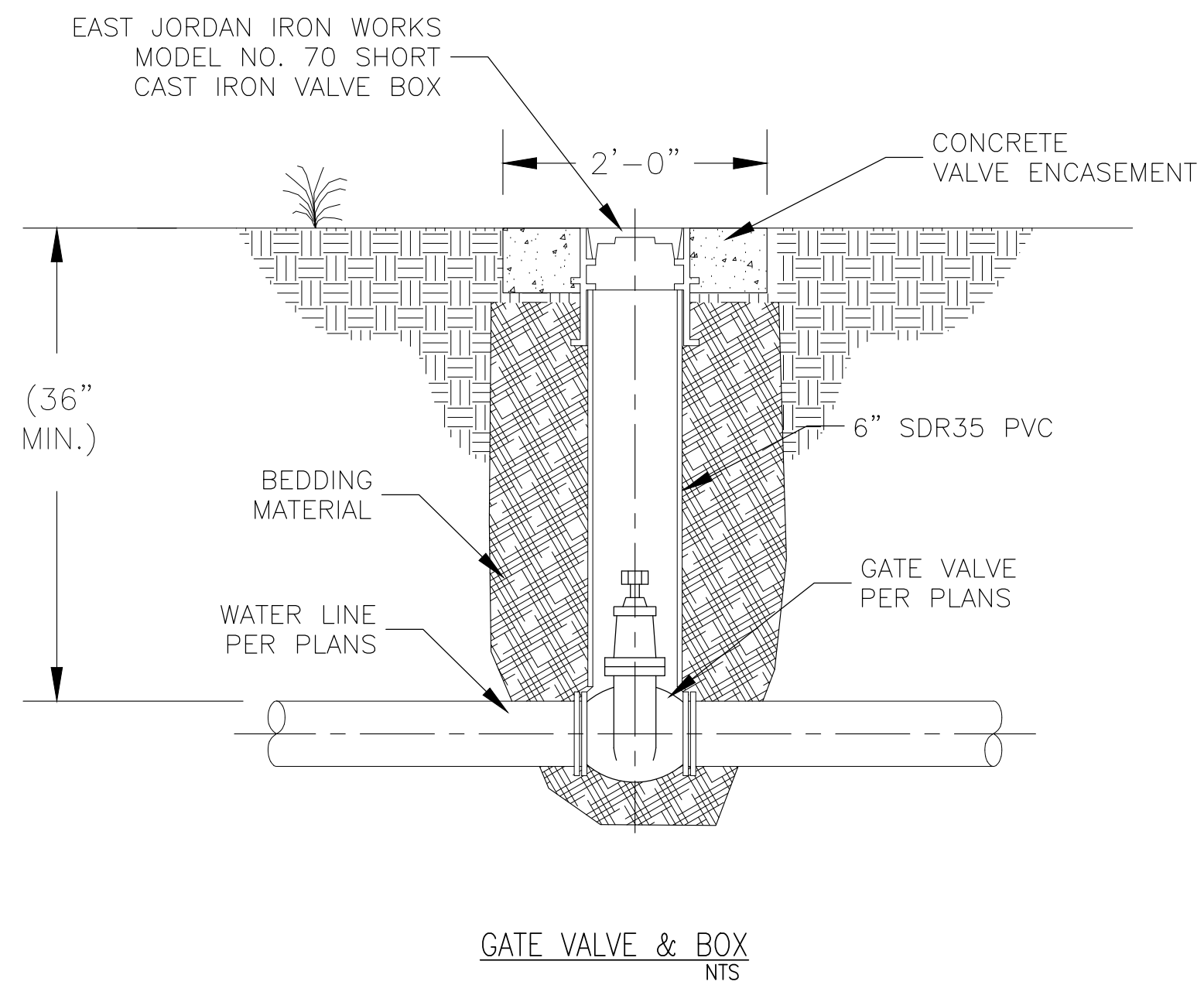

NOTE:
ALL BURIED VALVES SHALL BE FURNISHED WITH VALVE BOX.

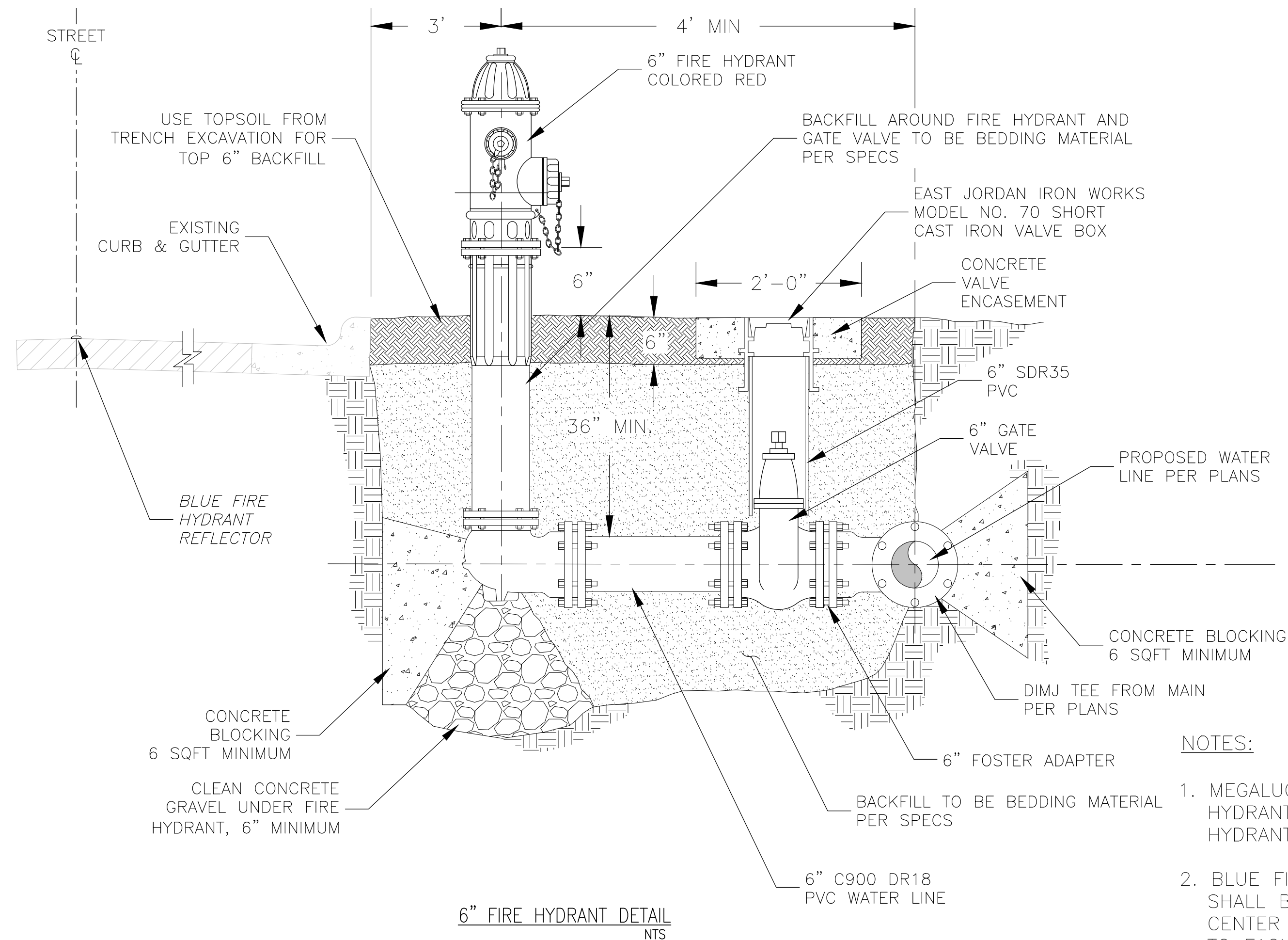

NOTES:

- MEGALUGS SHALL BE USED ON FIRE HYDRANT TEE, GATE VALVE, FIRE HYDRANT & ALL FITTINGS
- BLUE FIRE HYDRANT REFLECTOR SHALL BE INSTALLED IN PAVEMENT AT CENTER OF STREET AND PERPENDICULAR TO EACH FIRE HYDRANT INSTALLED.

- NOTES:**
- BLOCKING REQ'D. ON ALL BENDS 2" & LARGER. ALL REQ'D. BENDS & FITTINGS ARE NOT LABELED ON THE PLANS. PIPE MAY BE CURVED UP TO 75% OF MFG. RECOMMENDED MAX. CURVATURE WITHOUT A BEND AS APPROVED BY OWNER & ENGINEER.
 - ALL IRON FITTINGS & VALVES SHALL BE ENCAPSULATED IN 8 MIL POLYETHYLENE PER SPECS.
 - CONTRACTOR SHALL USE MEGA LUG RESTRAINTS FOR ALL FITTINGS.

DIMENSIONS FOR CONCRETE THRUST BLOCKS			
Pipe Dia. Size (Inches)	Minimum Soil Bearing Area Required (Square Feet)	Typical Dimensions Of Bearing Area In Inches (A x B)	Typical Volume Of Conc. Required (Cubic Feet) *
2	2.0	12" x 24"	3.0
2 1/2	2.5	12" x 30"	4.0
3	3.0	14" x 30"	4.5
4	4.0	18" x 32"	6.0
6	6.0	24" x 36"	9.0
8	8.0	29" x 40"	12.0
10	10.0	30" x 48"	15.0
12 & 14	12.0	36" x 48"	18.0
20	20.0	45" x 64"	36.0

* VARIES CONSIDERABLY W/DISTANCE BETWEEN PIPE AND BEARING POINT

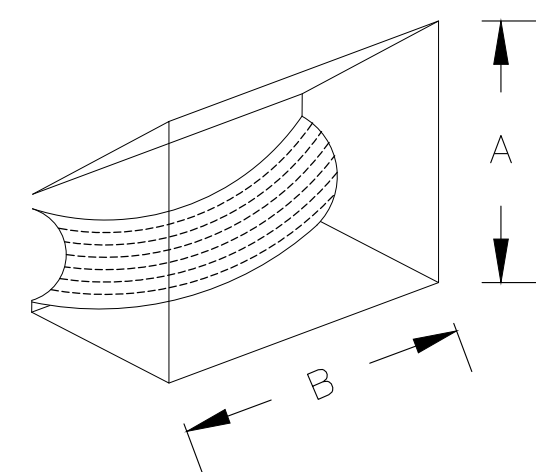

TYPICAL BLOCKING DIMENSIONS
NTS

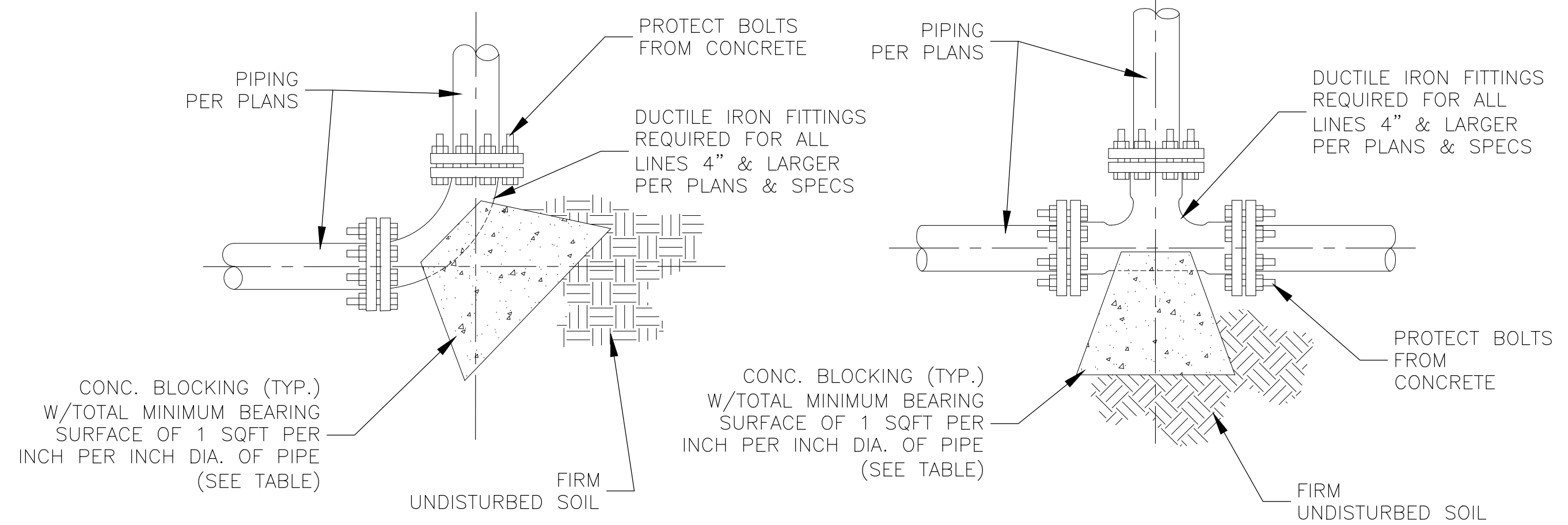

TYPICAL BLOCKING DETAILS
NTS



8465 CURRENCY LANE
 ASILENE, TX 79606
 325-695-1070
 1508 SANTA FE DR, STE 204
 WEATHERFORD, TX 76066
 817-594-9880



TEXAS STATE TECHNICAL COLLEGE
 10-INCH FIRE LOOP
 WATER LINE DETAILS (1)

SCALE	AS SHOWN
PROJECT #	19111
DESIGNED	HKH
DRAWN	RLM
CHECKED	HKH

DATE
 NO. REVISION
 SHEET 09
 SEQ. 09 OF 11
 BAR IS ONE INCH IN LENGTH ON ORIGINAL DRAWING. CHECK SCALE & ADJUST ACCORDINGLY.

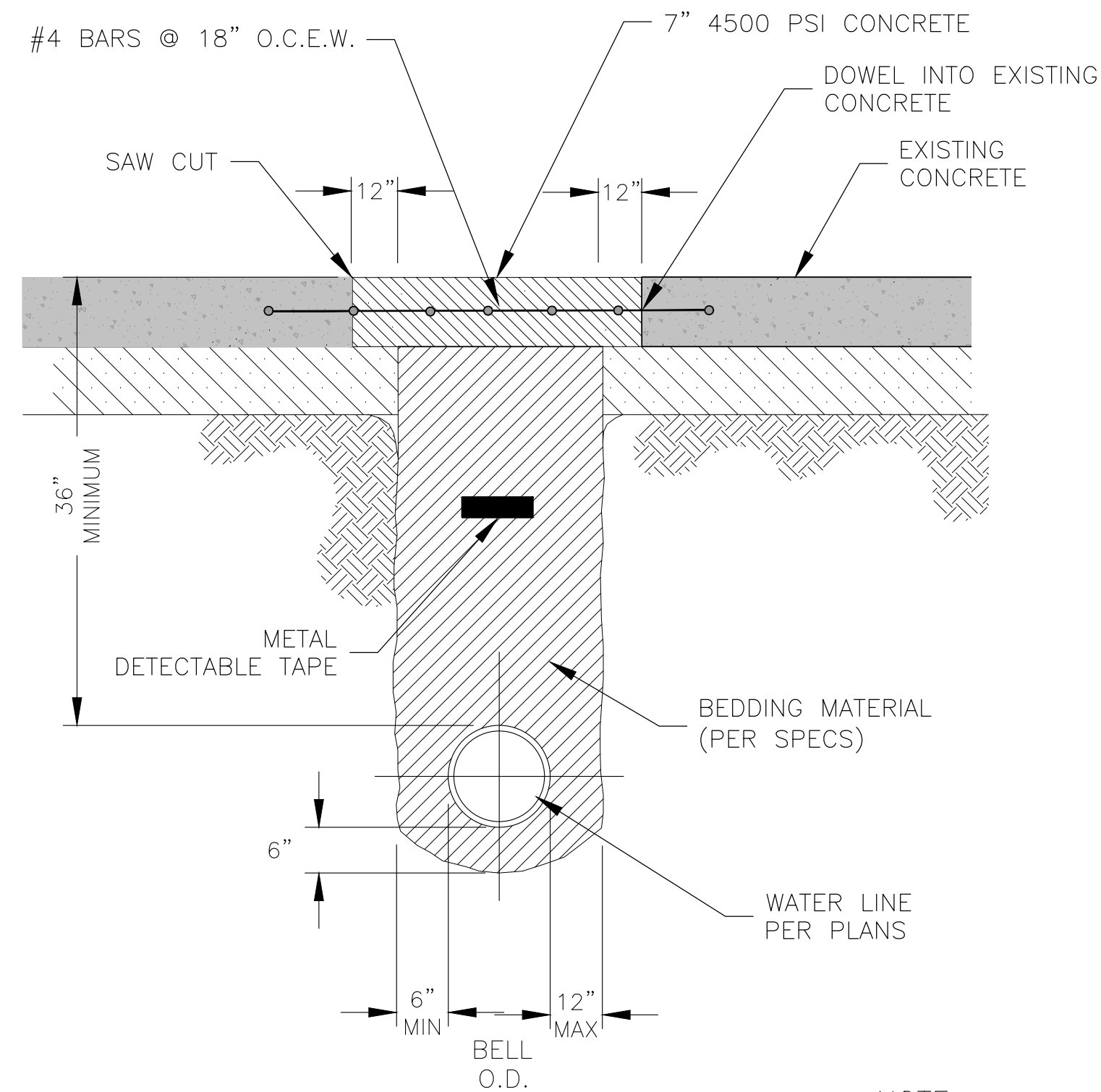

TRENCH WITHIN CONCRETE AREAS

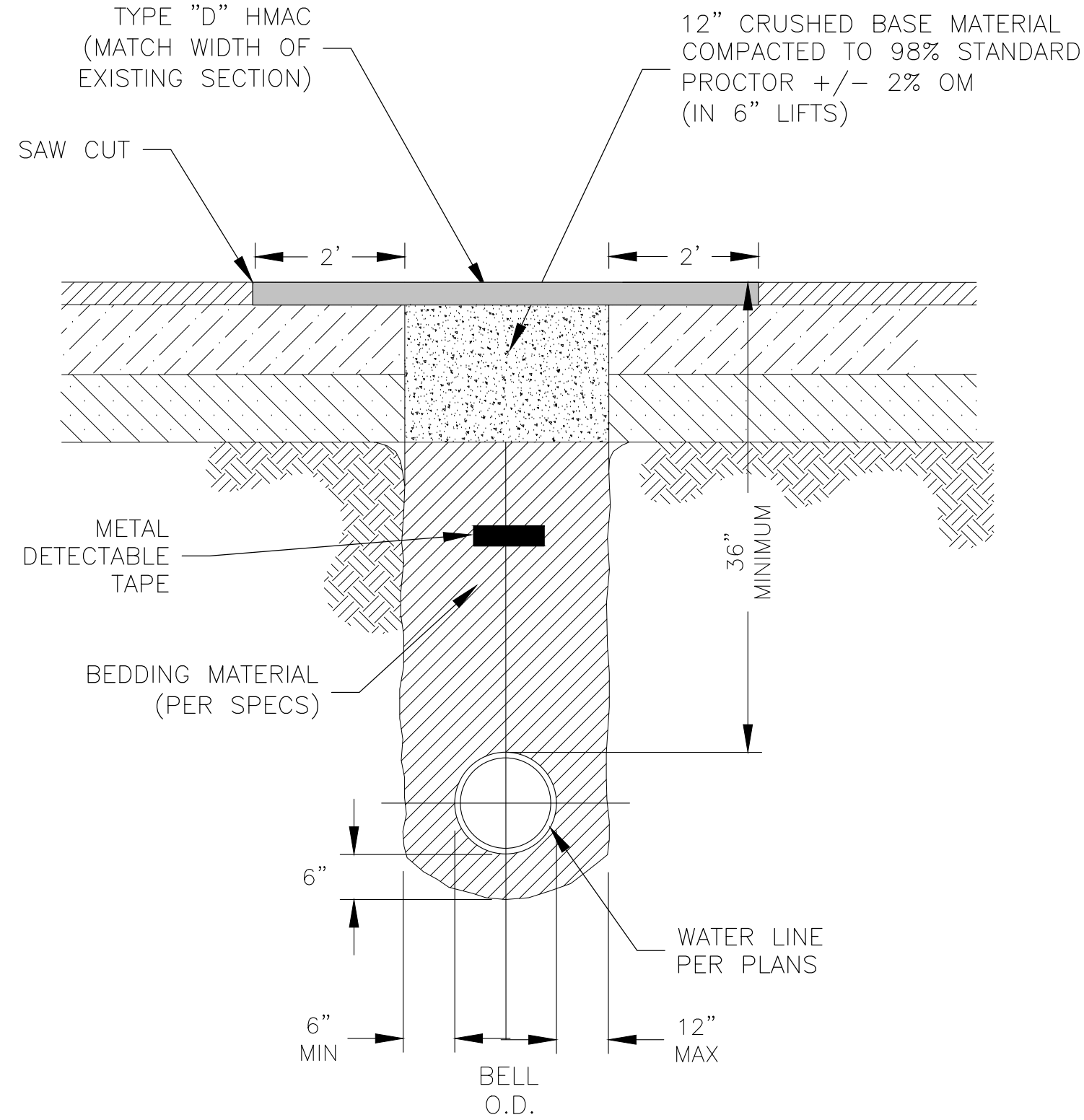

TRENCH WITHIN ASPHALT AREAS

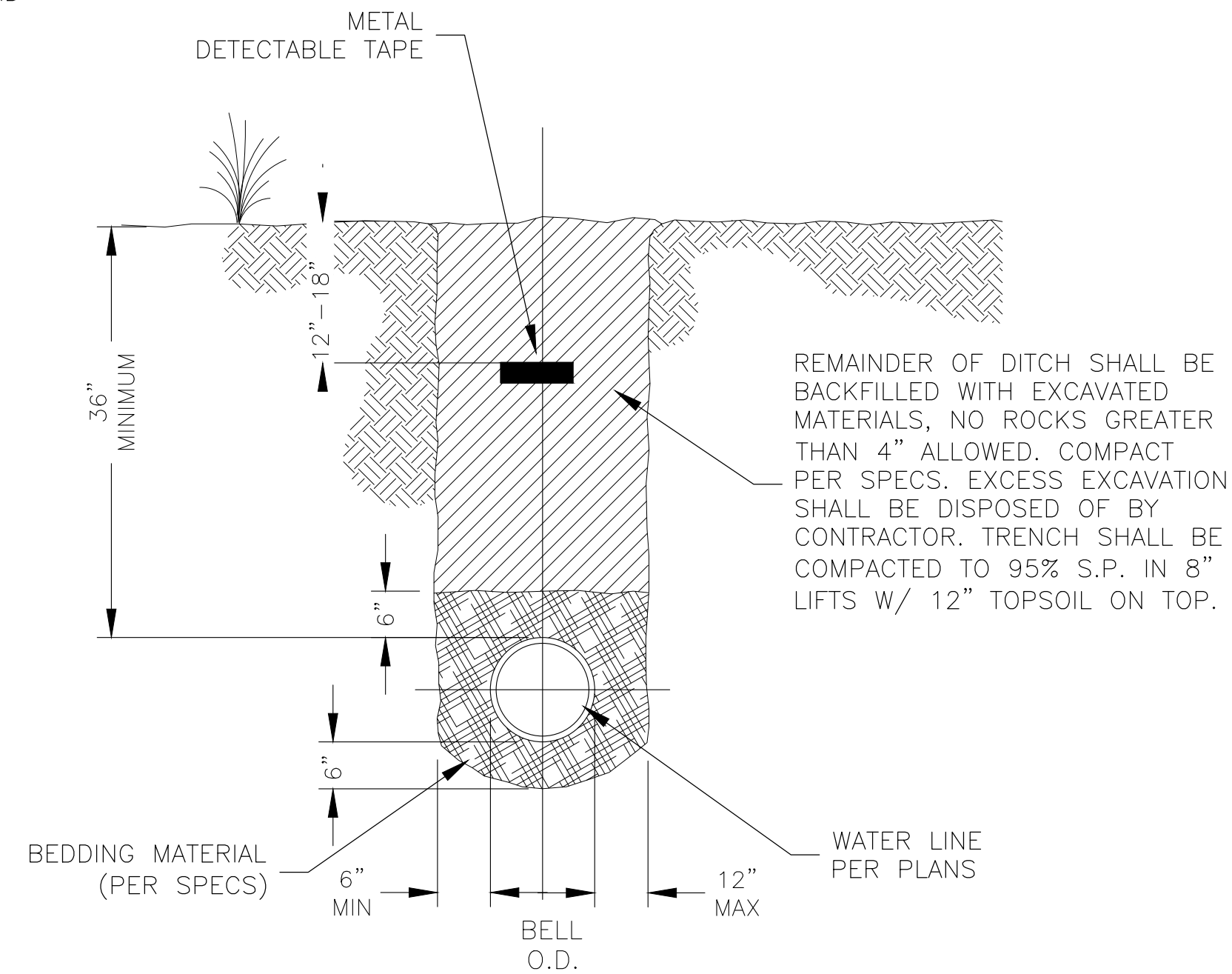

TRENCH OUTSIDE OF PAVED AREAS

NOTE:
SAW CUTS FOR CONCRETE AND ASPHALT TRENCH SECTIONS SHALL BE CLEAN AND STRAIGHT. ASPHALT SHALL ONLY BE PLACED WITHIN SAW CUT LINES.

TRENCH DETAILS
NTS

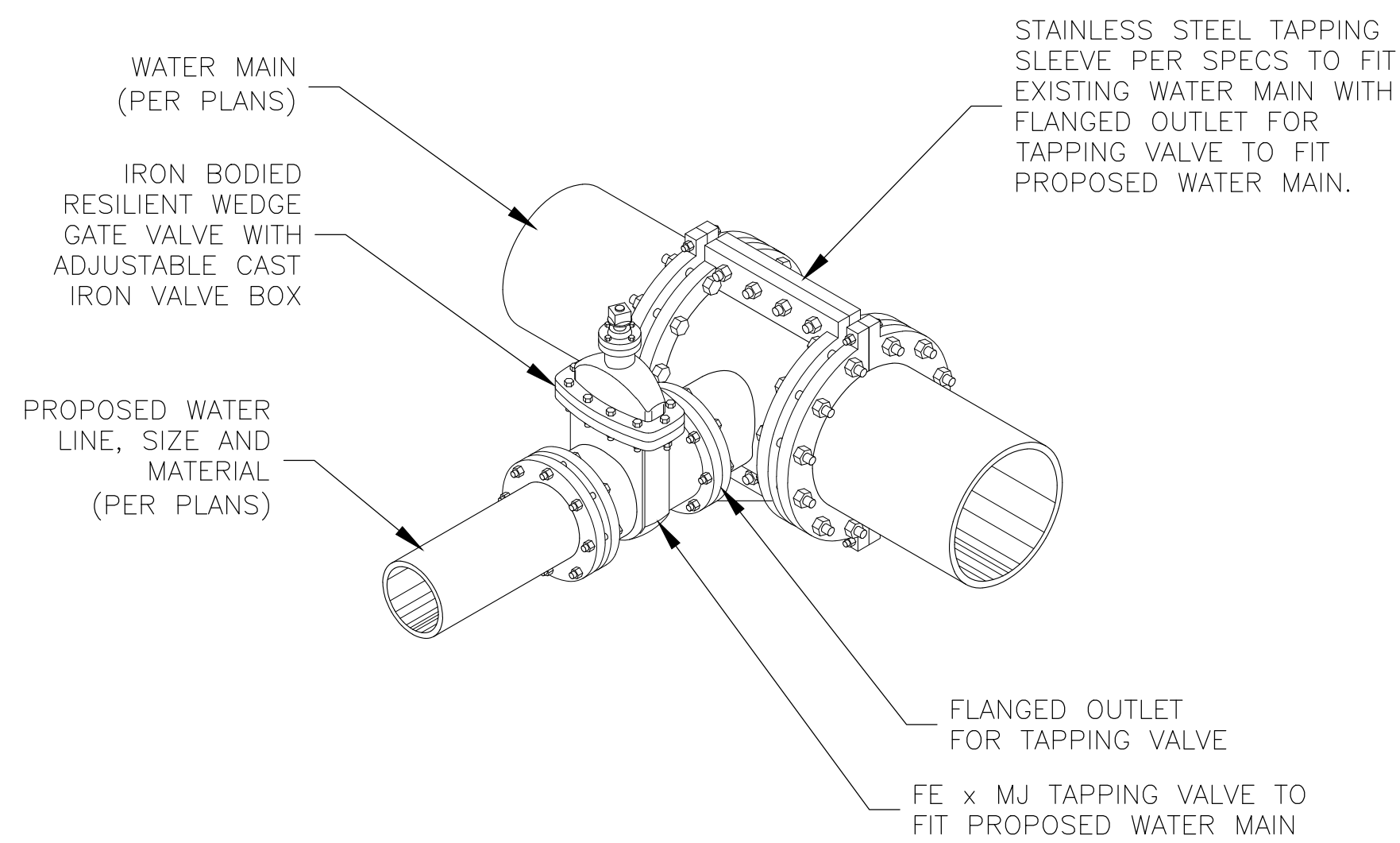

MAIN-LINE TAP CONNECTION DETAIL
NTS



8485 CURRY LANE
ASILENE, TX 79606
325-695-1070
1508 SANTA FE DR, STE 204
WEATHERFORD, TX 76086
817-594-9880
1014 BROADWAY STREET
LUBBOCK, TX 79401
806-365-6375



TEXAS STATE TECHNICAL COLLEGE

10-INCH FIRE LOOP

WATER LINE DETAILS (2)

SCALE	AS SHOWN
PROJECT #	19111
DESIGNED	HKH
DRAWN	RLM
CHECKED	HKH

DATE

BAR IS ONE INCH IN LENGTH ON ORIGINAL DRAWING.
CHECK SCALE & ADJUST ACCORDINGLY.

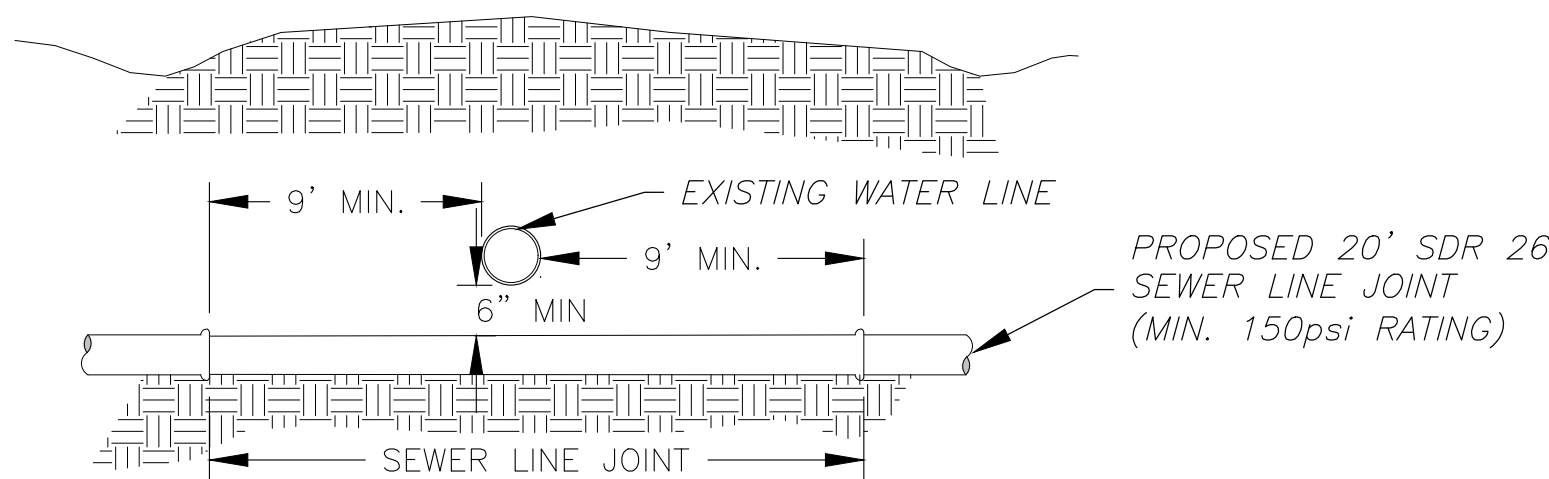

PROPOSED SEWER LINE CROSSING UNDER EXISTING WATER LINE
(PER TCEQ SEE SPECIFICATIONS) NTS

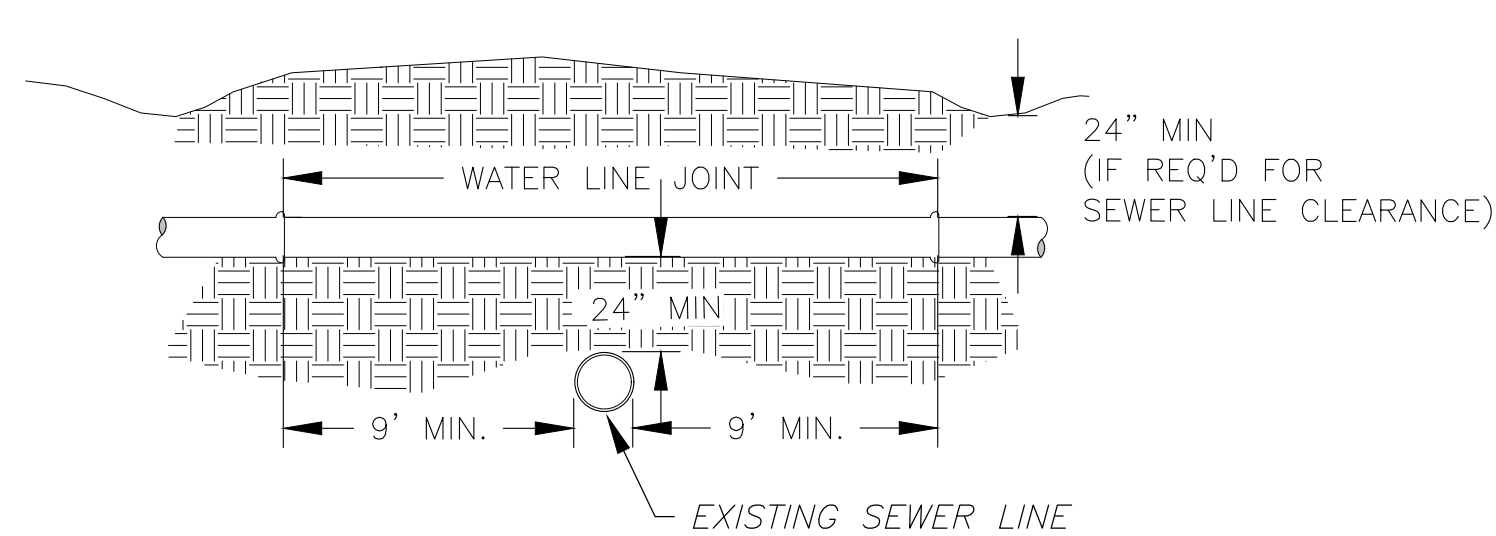

PROPOSED WATER LINE CROSSING OVER EXISTING SEWER LINE
(PER TCEQ SEE SPECIFICATIONS) NTS

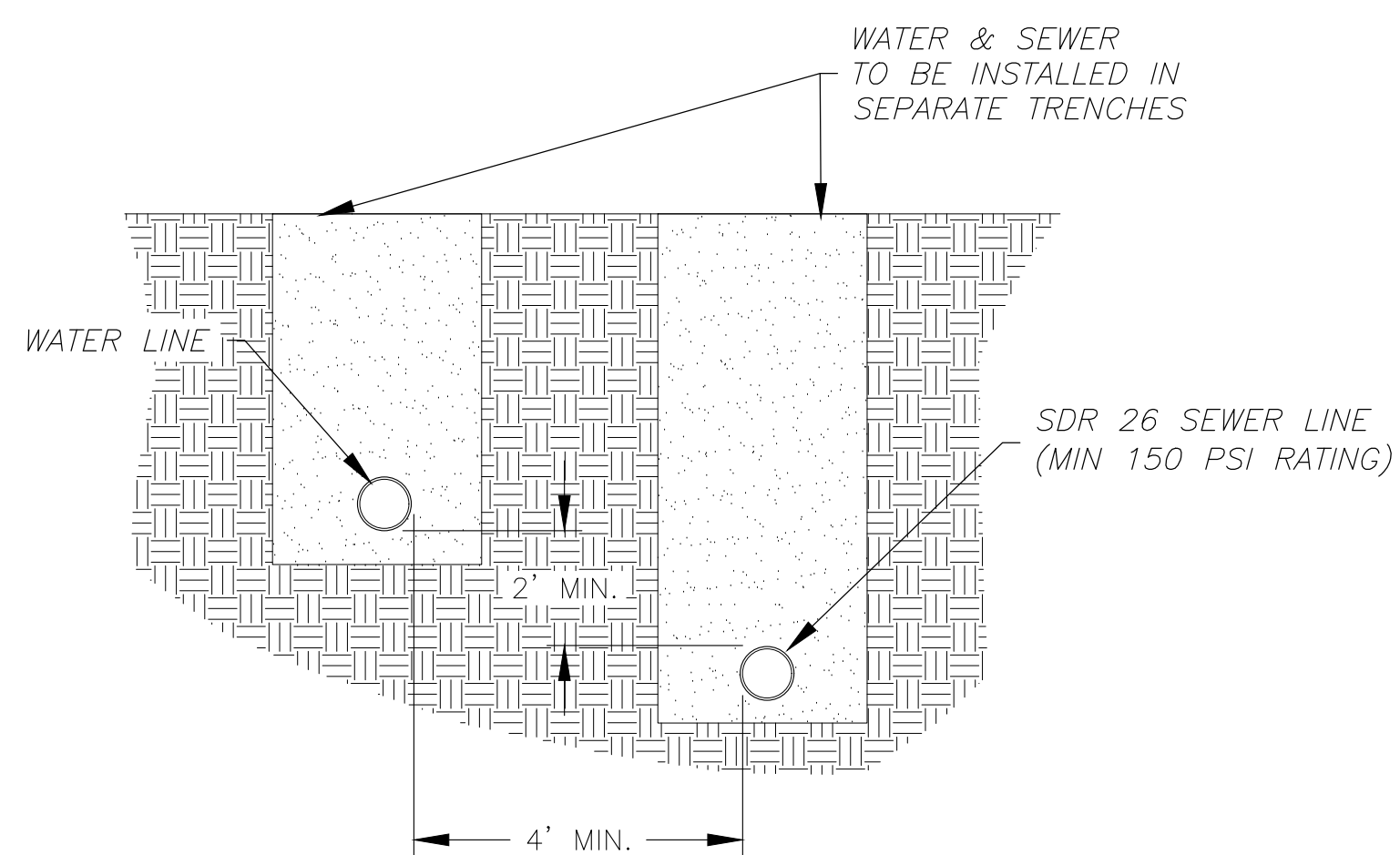

PARALLEL WATER AND SEWER LINES
(WHEN 9' SEPARATION IS NOT POSSIBLE) NTS

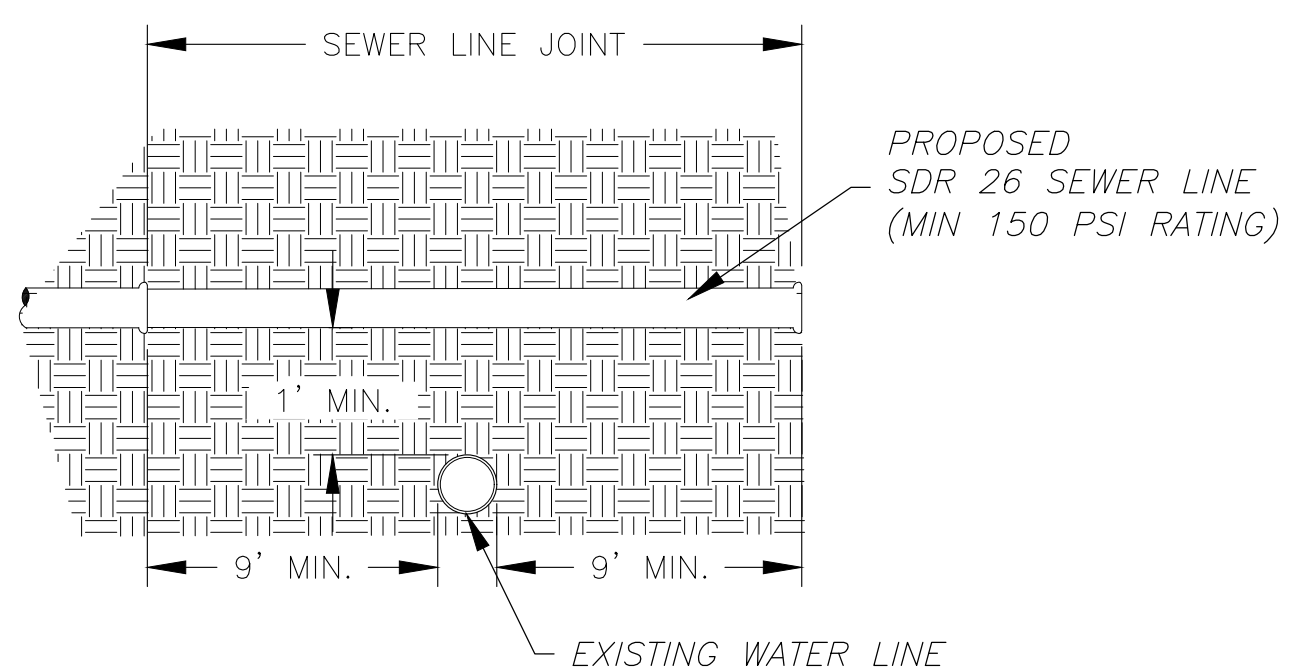

PROPOSED SEWER LINE CROSSING OVER EXISTING WATER LINE
NTS

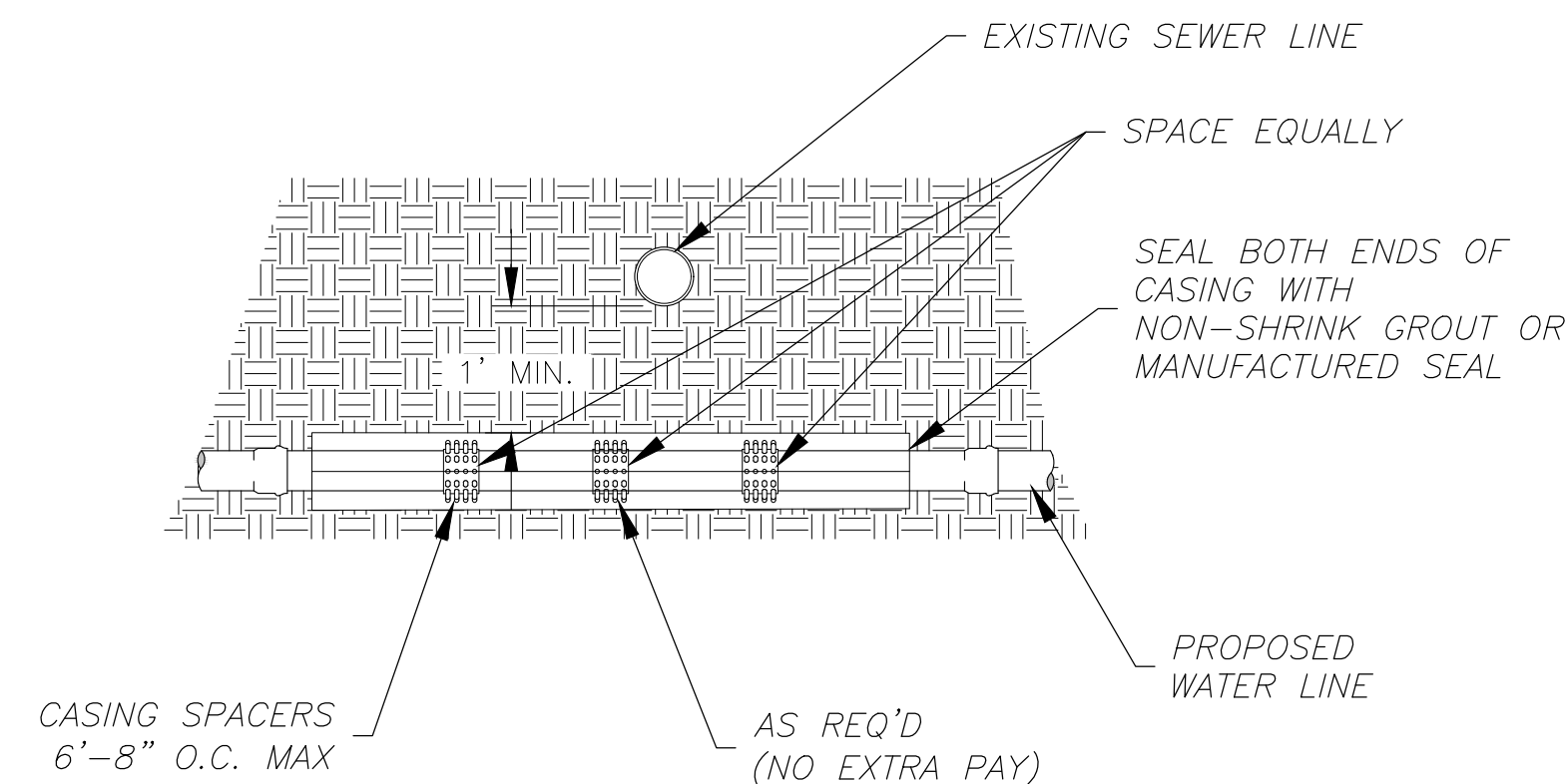

PROPOSED WATER LINE CROSSING UNDER EXISTING SEWER LINE
NTS

TCEQ TAC CHAPTER 290.44(e) WATER & SEWER SEPARATION NOTES:

- (e) LOCATION OF WATERLINES. THE FOLLOWING RULES APPLY TO INSTALLATIONS OF WATERLINES, WASTEWATER MAINS OR LATERALS, AND OTHER CONVEYANCES/APPURTENANCES IDENTIFIED AS POTENTIAL SOURCES OF CONTAMINATION. FURTHERMORE, ALL RATINGS SPECIFIED SHALL BE DEFINED BY ASTM OR AWWA STANDARDS UNLESS STATED OTHERWISE. NEW MAINS, SERVICE LINES, OR LATERALS ARE THOSE THAT ARE INSTALLED WHERE NO MAIN, SERVICE LINE, OR LATERAL PREVIOUSLY EXISTED, OR WHERE EXISTING MAINS, SERVICE LINES, OR LATERALS ARE REPLACED WITH PIPES OF DIFFERENT SIZE OR MATERIAL.
 - (1) WHEN NEW POTABLE WATER DISTRIBUTION LINES ARE CONSTRUCTED, THEY SHALL BE INSTALLED NO CLOSER THAN NINE FEET IN ALL DIRECTIONS TO WASTEWATER COLLECTION FACILITIES. ALL SEPARATION DISTANCES SHALL BE MEASURED FROM THE OUTSIDE SURFACE OF EACH OF THE RESPECTIVE PIECES.
 - (2) POTABLE WATER DISTRIBUTION LINES AND WASTEWATER MAINS OR LATERALS THAT FORM PARALLEL UTILITY LINES SHALL BE INSTALLED IN SEPARATE TRENCHES.
 - (3) NO PHYSICAL CONNECTION SHALL BE MADE BETWEEN A DRINKING WATER SUPPLY AND A SEWER LINE. ANY APPURTENANCE SHALL BE DESIGNED AND CONSTRUCTED SO AS TO PREVENT ANY POSSIBILITY OF SEWAGE ENTERING THE DRINKING WATER SYSTEM.
 - (4) WHERE THE NINE-FOOT SEPARATION DISTANCE CANNOT BE ACHIEVED, THE FOLLOWING CRITERIA SHALL APPLY.
 - (A) NEW WATERLINE INSTALLATION - PARALLEL LINES.
 - (i) WHERE A NEW POTABLE WATERLINE PARALLELS AN EXISTING, NON-PRESSURE OR PRESSURE RATED WASTEWATER MAIN OR LATERAL AND THE LICENSED PROFESSIONAL ENGINEER LICENSED IN THE STATE OF TEXAS IS ABLE TO DETERMINE THAT THE EXISTING WASTEWATER MAIN OR LATERAL IS NOT LEAKING, THE NEW POTABLE WATERLINE SHALL BE LOCATED AT LEAST TWO FEET ABOVE THE EXISTING WASTEWATER MAIN OR LATERAL, MEASURED VERTICALLY, AND AT LEAST FOUR FEET AWAY, MEASURED HORIZONTALLY, FROM THE EXISTING WASTEWATER MAIN OR LATERAL. EVERY EFFORT SHALL BE EXERTED NOT TO DISTURB THE BEDDING AND BACKFILL OF THE EXISTING WASTEWATER MAIN OR LATERAL.
 - (ii) WHERE A NEW POTABLE WATERLINE PARALLELS AN EXISTING PRESSURE-RATED WASTEWATER MAIN OR LATERAL AND IT CANNOT BE DETERMINED BY THE LICENSED PROFESSIONAL ENGINEER IF THE EXISTING LINE IS LEAKING, THE EXISTING WASTEWATER MAIN OR LATERAL SHALL BE REPLACED WITH AT LEAST 150 PSI PRESSURE-RATED PIPE. THE NEW POTABLE WATERLINE SHALL BE LOCATED AT LEAST TWO FEET ABOVE THE NEW WASTEWATER LINE, MEASURED VERTICALLY, AND AT LEAST FOUR FEET AWAY, MEASURED HORIZONTALLY, FROM THE REPLACED WASTEWATER MAIN OR LATERAL.
 - (iii) WHERE A NEW POTABLE WATERLINE PARALLELS A NEW WASTEWATER MAIN, THE WASTEWATER MAIN OR LATERAL SHALL BE CONSTRUCTED OF AT LEAST 150 PSI PRESSURE-RATED PIPE. THE NEW POTABLE WATERLINE SHALL BE LOCATED AT LEAST TWO FEET ABOVE THE WASTEWATER MAIN OR LATERAL, MEASURED VERTICALLY, AND AT LEAST FOUR FEET AWAY, MEASURED HORIZONTALLY, FROM THE WASTEWATER MAIN OR LATERAL.
 - (B) NEW WATERLINE INSTALLATION - CROSSING LINES.
 - (i) WHERE A NEW POTABLE WATERLINE CROSSES ABOVE A WASTEWATER MAIN OR LATERAL, THE SEGMENT OF THE WATERLINE PIPE SHALL BE CENTERED OVER AND MUST BE PERPENDICULAR TO THE WASTEWATER MAIN OR LATERAL SUCH THAT THE JOINTS OF THE WATERLINE PIPE ARE EQUIDISTANT AND AT LEAST NINE FEET HORIZONTALLY FROM THE CENTERLINE OF THE WASTEWATER MAIN OR LATERAL. WHEN CROSSING AN EXISTING WASTEWATER MAIN OR LATERAL AND IT IS DISTURBED OR SHOWS SIGNS OF LEAKING, THE WASTEWATER MAIN OR LATERAL SHALL BE REPLACED FOR AT LEAST NINE FEET IN BOTH DIRECTIONS (18 FEET TOTAL) WITH AT LEAST 150 PSI PRESSURE-RATED PIPE EMBEDDED IN CEMENT STABILIZED SAND (SEE CLAUSE (V) OF THIS SUBPARAGRAPH) FOR THE TOTAL LENGTH OF ONE PIPE SEGMENT PLUS 12 INCHES BEYOND THE JOINT ON EACH END.

- (i) THE POTABLE WATERLINE SHALL BE AT LEAST TWO FEET ABOVE AN EXISTING, NON-PRESSURE RATED WASTEWATER MAIN OR LATERAL.
- (ii) THE POTABLE WATERLINE SHALL BE AT LEAST SIX INCHES ABOVE AN EXISTING, PRESSURE-RATED WASTEWATER MAIN OR LATERAL.
- (ii) WHERE A NEW POTABLE WATERLINE CROSSES A NEW, NON-PRESSURE RATED WASTEWATER MAIN OR LATERAL, THE SEGMENT OF THE WATERLINE PIPE SHALL BE CENTERED OVER AND SHALL BE PERPENDICULAR TO THE WASTEWATER MAIN OR LATERAL SUCH THAT THE JOINTS OF THE WATERLINE PIPE ARE EQUIDISTANT AND AT LEAST NINE FEET HORIZONTALLY FROM THE CENTERLINE OF THE WASTEWATER MAIN OR LATERAL. THE POTABLE WATERLINE SHALL BE AT LEAST TWO FEET ABOVE THE WASTEWATER MAIN OR LATERAL. WHENEVER POSSIBLE, THE CROSSING SHALL BE CENTERED BETWEEN THE JOINTS OF THE WASTEWATER MAIN OR LATERAL. THE WASTEWATER PIPE SHALL HAVE A MINIMUM PIPE STIFFNESS OF 115 PSI AT 5.0% DEFLECTION. THE WASTEWATER MAIN OR LATERAL SHALL BE EMBEDDED IN CEMENT STABILIZED SAND (SEE CLAUSE (V) OF THIS SUBPARAGRAPH) FOR THE TOTAL LENGTH OF ONE PIPE SEGMENT PLUS 12 INCHES BEYOND THE JOINT ON EACH END. THE MATERIALS AND METHOD OF INSTALLATION SHALL CONFORM TO ONE OF THE FOLLOWING OPTIONS:
 - (i) WITHIN NINE FEET HORIZONTALLY OF EITHER SIDE OF THE WATERLINE, THE WASTEWATER PIPE AND JOINTS SHALL BE CONSTRUCTED WITH PIPE MATERIAL HAVING A MINIMUM PRESSURE RATING OF AT LEAST 150 PSI. AN ABSOLUTE MINIMUM VERTICAL SEPARATION DISTANCE OF TWO FEET SHALL BE PROVIDED. THE WASTEWATER MAIN OR LATERAL SHALL BE LOCATED BELOW THE WATERLINE.
 - (ii) ALL SECTIONS OF WASTEWATER MAIN OR LATERAL WITHIN NINE FEET HORIZONTALLY OF THE WATERLINE SHALL BE ENCASED IN AN 18-FOOT (OR LONGER) SECTION OF PIPE. FLEXIBLE ENCASED PIPE SHALL HAVE A MINIMUM PIPE STIFFNESS OF 115 PSI AT 5.0% DEFLECTION. THE ENCASED PIPE SHALL BE CENTERED ON THE WATERLINE AND SHALL BE AT LEAST TWO NOMINAL PIPE DIAMETERS LARGER THAN THE WASTEWATER MAIN OR LATERAL. THE SPACE AROUND THE CARRIER PIPE SHALL BE SUPPORTED AT FIVE-FOOT (OR LESS) INTERVALS WITH SPACERS OR BE FILLED TO THE SPRINGLINE WITH WASHED SAND. EACH END OF THE CASING SHALL BE SEALED WITH WATERTIGHT NON-SHRINK CEMENT GROUT OR A MANUFACTURED WATERTIGHT SEAL. AN ABSOLUTE MINIMUM SEPARATION DISTANCE OF SIX INCHES BETWEEN THE ENCASEMENT PIPE AND THE WATERLINE SHALL BE PROVIDED. THE WASTEWATER LINE SHALL BE LOCATED BELOW THE WATERLINE.

- (iii) WHEN A NEW WATERLINE CROSSES UNDER A WASTEWATER MAIN OR LATERAL, THE WATERLINE SHALL BE ENCASED AS DESCRIBED FOR WASTEWATER MAINS OR LATERALS IN CLAUSE (ii) OF THIS SUBPARAGRAPH OR CONSTRUCTED OF DUCTILE IRON OR STEEL PIPE WITH MECHANICAL OR WELDED JOINTS AS APPROPRIATE. AN ABSOLUTE MINIMUM SEPARATION DISTANCE OF ONE FOOT BETWEEN THE WATERLINE AND THE WASTEWATER MAIN OR LATERAL SHALL BE PROVIDED. WHEN A NEW WATERLINE CROSSES UNDER A WASTEWATER MAIN, THE PROCEDURES IN §217.53(D) OF THIS TITLE (RELATING TO PIPE DESIGN) MUST BE FOLLOWED.
- (iv) WHERE A NEW POTABLE WATERLINE CROSSES A NEW, PRESSURE RATED WASTEWATER MAIN OR LATERAL, ONE SEGMENT OF THE WATERLINE PIPE SHALL BE CENTERED OVER AND SHALL BE PERPENDICULAR TO THE WASTEWATER LINE SUCH THAT THE JOINTS OF THE WATERLINE PIPE ARE EQUIDISTANT AND AT LEAST NINE FEET HORIZONTALLY FROM THE CENTER LINE OF THE WASTEWATER MAIN OR LATERAL. THE POTABLE WATERLINE SHALL BE AT LEAST SIX INCHES ABOVE THE WASTEWATER MAIN OR LATERAL. WHENEVER POSSIBLE, THE CROSSING SHALL BE CENTERED BETWEEN THE JOINTS OF THE WASTEWATER MAIN OR LATERAL. THE WASTEWATER PIPE SHALL HAVE A MINIMUM PRESSURE RATING OF AT LEAST 150 PSI. THE WASTEWATER MAIN OR LATERAL SHALL BE EMBEDDED IN CEMENT STABILIZED SAND (SEE CLAUSE (V) OF THIS SUBPARAGRAPH) FOR THE TOTAL LENGTH OF ONE PIPE SEGMENT PLUS 12 INCHES BEYOND THE JOINT ON EACH END.
- (v) WHERE CEMENT STABILIZED SAND BEDDING IS REQUIRED, THE CEMENT STABILIZED SAND SHALL HAVE A MINIMUM OF 10% CEMENT PER CUBIC YARD OF CEMENT STABILIZED SAND MIXTURE, BASED ON LOOSE DRY WEIGHT VOLUME (AT LEAST 2.5 BAGS OF CEMENT PER CUBIC YARD OF MIXTURE). THE CEMENT STABILIZED SAND BEDDING SHALL BE A MINIMUM OF SIX INCHES ABOVE AND FOUR INCHES BELOW THE WASTEWATER MAIN OR LATERAL. THE USE OF BROWN COLORING IN CEMENT STABILIZED SAND FOR WASTEWATER MAIN OR LATERAL BEDDING IS RECOMMENDED FOR THE IDENTIFICATION OF PRESSURE RATED WASTEWATER MAINS DURING FUTURE CONSTRUCTION.
- (5) WATERLINE AND WASTEWATER MAIN MANHOLE OR LATERAL MANHOLE OR CLEANOUT SEPARATION. THE SEPARATION DISTANCE FROM A POTABLE WATERLINE TO A WASTEWATER MAIN MANHOLE OR LATERAL MANHOLE OR CLEANOUT SHALL BE A MINIMUM OF NINE FEET. WHERE THE NINE-FOOT SEPARATION DISTANCE CANNOT BE ACHIEVED, THE POTABLE WATERLINE SHALL BE ENCASED IN A JOINT OF AT LEAST 150 PSI PRESSURE CLASS PIPE AT LEAST 18 FEET LONG AND TWO NOMINAL SIZES LARGER THAN THE NEW CONVEYANCE. THE SPACE AROUND THE CARRIER PIPE SHALL BE SUPPORTED AT FIVE-FOOT INTERVALS WITH SPACERS OR BE FILLED TO THE SPRINGLINE WITH WASHED SAND. THE ENCASEMENT PIPE SHALL BE CENTERED ON THE CROSSING AND BOTH ENDS SEALED WITH CEMENT GROUT OR MANUFACTURED SEALANT.
- (6) LOCATION OF FIRE HYDRANTS. FIRE HYDRANTS SHALL NOT BE INSTALLED WITHIN NINE FEET VERTICALLY OR HORIZONTALLY OF ANY WASTEWATER MAIN, WASTEWATER LATERAL, OR WASTEWATER SERVICE LINE REGARDLESS OF CONSTRUCTION.
- (7) LOCATION OF POTABLE OR RAW WATER SUPPLY OR SUCTION LINES. SUCTION MAINS TO PUMPING EQUIPMENT SHALL NOT CROSS WASTEWATER MAINS, WASTEWATER LATERALS, OR WASTEWATER SERVICE LINES. RAW WATER SUPPLY LINES SHALL NOT BE INSTALLED WITHIN FIVE FEET OF ANY TILE OR CONCRETE WASTEWATER MAIN, WASTEWATER LATERAL, OR WASTEWATER SERVICE LINE.
- (8) PROXIMITY OF SEPTIC TANK DRAINFIELDS. WATERLINES SHALL NOT BE INSTALLED CLOSER THAN TEN FEET TO SEPTIC TANK DRAINFIELDS.



3465 CURRY LANE
ASILENE, TX 79606
325-695-1070
1508 SANTA FE DR, STE 204
WEATHERFORD, TX 76086
817-594-9880
1014 BROADWAY STREET
LUBBOCK, TX 79401
806-365-6375



TEXAS STATE TECHNICAL COLLEGE
10-INCH FIRE LOOP
WATER LINE DETAILS (3)

SCALE	AS SHOWN	PROJECT #	19111	DESIGNED	HKH	DRAWN	RLM	CHECKED	HKH
DATE									
NO.	REVISION								
SHEET 11									
SEQ. 11 OF 11									

BAR IS ONE INCH IN LENGTH ON ORIGINAL DRAWING.
CHECK SCALE & ADJUST ACCORDINGLY.

ATTACHMENT C - BID SCHEDULE
TEXAS STATE TECHNICAL COLLEGE
BID SCHEDULE
10-INCH FIRE LOOP

Show prices in numerals. Round off unit prices to two decimal places only.

These Bid Prices must include all labor, material, equipment, insurance, overhead, superintendence, transportation, taxes, permits, profits & incidentals to cover the finished Work called for in the Contract Documents.

For all Labor, Material, Equipment and Incidentals to Install the Following:

Bid		Est.		Unit	Extended
Item	Description	Qty.	Unit	Price	Amount
1	Mobilization, Bonding and Insurance	1	LS	\$	\$
2	10" DR18 C900 PVC Water Line	5,254	LF	\$	\$
3	6" DR18 C900 PVC Water Line	190	LF	\$	\$
4	10" Gate Valve and Box	4	EA	\$	\$
5	6" Gate Valve and Box	10	EA	\$	\$
6	8" Tapping Sleeve and 8" Tapping Valve	2	EA	\$	\$
7	8" x 6" Tapping Sleeve and 6" Tapping Valve	1	EA	\$	\$
8	6" Fire Hydrant	10	EA	\$	\$
9	6" Fire Hydrant Reconnect	1	EA	\$	\$
10	Remove Existing Fire Hydrant & Valve and Plug Existing Water Line	5	EA	\$	\$
11	Metal Detectable Tap	5,444	LF	\$	\$
12	Crushed Asphalt Parking Lot Repair	480	LF	\$	\$
13	Concrete Flatwork Repair	17	LF	\$	\$
14	Asphalt Pavement Repair	2,040	LF	\$	\$
15	Blue Fire Hydrant Reflectors	10	EA	\$	\$
<u>TOTAL BASE BID (Items 1 -15)</u>					\$

ATTACHMENT D - STATEMENT OF BIDDER'S QUALIFICATIONS

All questions must be answered and the date given must be clear and comprehensive. This statement must be notarized. If necessary, questions may be answered on separate attached sheets. The Bidder may submit any additional information he desires.

1. Bidder Information:

Name of Bidder: _____ Date organized: _____
Address: _____ Date incorporated: _____
Number of Years in contracting business under present name: _____

2. Contracts on hand:

Contract	Amount	Anticipated Completion Date

3. Type of work performed by your company: _____

4. Have you ever failed to complete any work awarded to you? If yes, explain: _____

5. Have you ever defaulted on a contract? If yes, explain: _____

6. Have you ever completed a project for Texas State Technical college? If yes, list projects completed. _____

7. List the projects recently completed by your company (be sure to include projects with similar scope of this project):

Project	Amount	Month/Year Completed	Provide Contact information

8. List major equipment available for this contract: _____

9. Attach resumes for the principal members of your organization, including the officers as well as the proposed superintendent for the project.

10. Credit Available: _____ Bank Reference: _____

The undersigned hereby authorizes and requests any person, firm, or corporation to furnish any information requested by the _____ in verification of the recitals comprising this Statement of Bidder's Qualifications.

Executed this _____ day of _____, 20____.

By: _____

Title: _____